

THEO-P173

Host-based V2X transceiver module

Data Sheet

Abstract

This technical data sheet describes the THEO-P173 Wi-Fi 802.11p module designed for applications such as traffic safety, intelligent traffic management and entertainment. This host-based module includes an integrated MAC/LLC/Baseband processor and required RF front-end components. The module can be connected to a host processor through the USB interface.

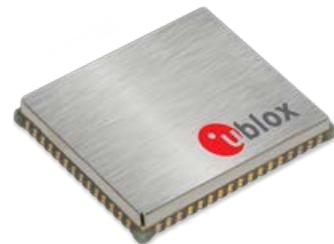

www.u-blox.com

UBX-15023940 - R02

Document Information

Title	THEO-P173		
Subtitle	Host-based V2X transceiver module		
Document type	Data Sheet		
Document number	UBX-15023940		
Revision and date	R02	30-Nov-2016	
Document status	Advance Information		

Document status explanation

Objective Specification	Document contains target values. Revised and supplementary data will be published later.		
Advance Information	Document contains data based on early testing. Revised and supplementary data will be published later.		
Early Production Information	Document contains data from product verification. Revised and supplementary data may be published later.		
Production Information	Document contains the final product specification.		

This document applies to the following products:

Product name	Type number	Firmware version	PCN / IN reference
THEO-P173	THEO-P173-01A-00	-	N/A

u-blox reserves all rights to this document and the information contained herein. Products, names, logos and designs described herein may in whole or in part be subject to intellectual property rights. Reproduction, use, modification or disclosure to third parties of this document or any part thereof without the express permission of u-blox is strictly prohibited.

The information contained herein is provided "as is" and u-blox assumes no liability for the use of the information. No warranty, either express or implied, is given, including but not limited, with respect to the accuracy, correctness, reliability and fitness for a particular purpose of the information. This document may be revised by u-blox at any time. For most recent documents, visit www.u-blox.com.

Copyright © 2016, u-blox AG.

u-blox® is a registered trademark of u-blox Holding AG in the EU and other countries. ARM® is the registered trademark of ARM Limited in the EU and other countries.

Contents

Contents	3
1 Functional description	5
1.1 Overview	5
1.2 Applications.....	5
1.3 Product features	5
1.4 Block diagram.....	6
1.5 Product description.....	6
1.6 Supported features.....	6
1.6.1 Compliance	7
1.7 MAC addresses.....	7
2 Host interfaces	8
2.1 USB interface.....	8
2.2 SPI interface.....	8
3 Pin definition	9
3.1 Pin assignment	9
4 Electrical specification	12
4.1 Absolute maximum ratings.....	12
4.2 Operating conditions	12
4.3 Digital pad ratings	12
4.4 Peak power consumption	13
4.5 Power consumption.....	13
4.6 Radio specifications	14
4.7 Example circuit	16
5 Environmental specification	17
6 Mechanical specifications	18
6.1 Dimensions.....	18
7 Qualification and approvals	19
7.1 Approvals	19
7.1.1 FCC compliance	19
7.2 FCC ID.....	19
8 Product handling	20
8.1 Packaging.....	20
8.2 Shipment, storage and handling	20
8.2.1 Moisture sensitivity levels.....	20
8.2.2 Mounting process and soldering recommendations.....	20

8.2.3	ESD handling precautions.....	20
9	Labeling and ordering information.....	21
9.1	Product labeling.....	21
9.2	Explanation of codes.....	21
9.3	Ordering codes.....	22
Appendix	23
A	Glossary	23
	Related documents.....	24
	Revision history.....	24
	Contact.....	25

1 Functional description

1.1 Overview

The THEO-P173 module is a compact, embedded transceiver module from u-blox that facilitates development of electronics for Vehicle-to-Everything (V2X) communication systems. This module can be used for applications such as traffic safety, intelligent traffic management, and entertainment.

The THEO-P173 module includes an integrated MAC/LLC/Baseband processor and the required RF front-end components. It is connected to a host processor through the USB interface. The THEO-P173 module is currently offered as version 1.

1.2 Applications

- Vehicle to vehicle communication
- Intelligent Transport System
- Vehicle Safety Services
- Vehicle to Infrastructure Communication
- Commercial transactions via cars

1.3 Product features

Model	Radio		Interfaces				Power	Features		Grade			
	802.11p	Max output power at antenna pin	Antenna type	USB 2.0	GPIO	1PPS	SPI ¹	Power supply: 3.3 V and 5 V	Single channel with antenna diversity	Multi-channel operation	Standard	Professional	Automotive
THEO-P173	•	23 dBm	2p	•	1	•	•	•	•	•			

2p = Two pins for separate external antennas

¹ SPI available in version 02A

Table 1: THEO-P173 main features summary

1.4 Block diagram

The block diagram of the THEO-P173 is shown in Figure 1.

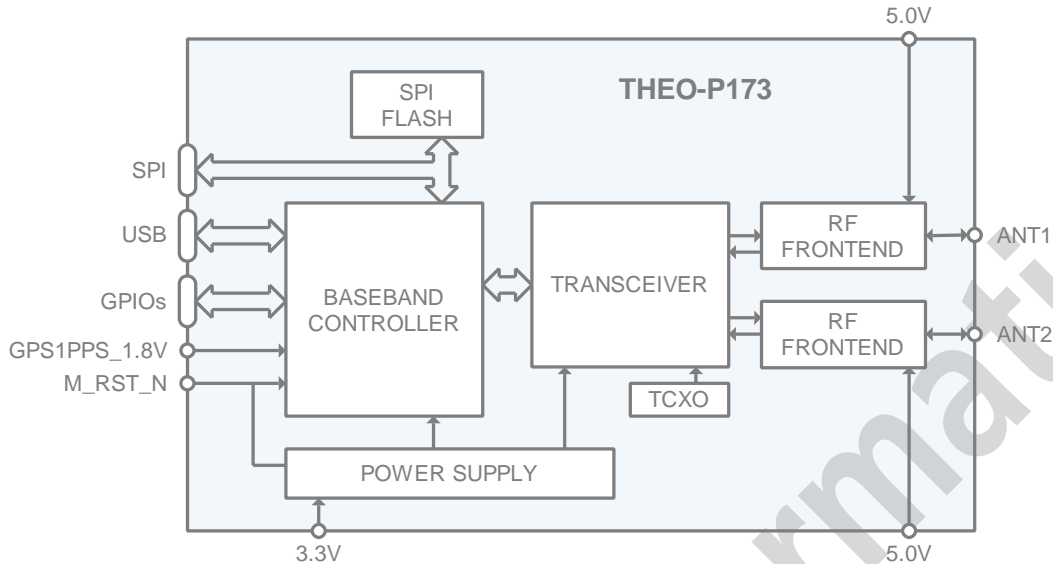

Figure 1: THEO-P173 block diagram

1.5 Product description

Model	Description
THEO-P173	Dual-antenna diversity and single channel

1.6 Supported features

The features supported in THEO-P173 are listed below:

Feature	Description
Standards	IEEE 802.11p – 2010 ETSI ES 202 663 IEEE 1609.4 – 2010
Frequency bands	5.850 – 5.925 GHz (channels 172, 174, 176, 178, 180, 182, 184)
Transmit power	5.9 GHz: -10 to +23 dBm 5.9 GHz: Class C
Receive sensitivity	5.9 GHz: -97 dBm @ 3 Mbps
Antenna diversity - 5.9 GHz only	CDD Transmit Diversity MRC Receive Diversity
Channel bandwidth	10, 20 MHz ¹
Supported data rates	3, 4.5, 6, 9, 12, 18, 24, 27 Mbps for 10 MHz bandwidth signal
Power supply	3.3 V and 5.0 V
Power consumption	4W (Maximum, Average)
Operating temperature	-40 °C to +85 °C
Dimensions	30.0 x 40.0 x 4.0 mm

¹ 20 MHz channel bandwidth is not supported by the firmware.

1.6.1 Compliance

- Compliance with WAVE and ETSI ITS G5 for US and Europe operations
- Radio type approvals for the United States (FCC)

1.7 MAC addresses

The THEO-P173 module does not store any MAC address internally, as the unique MAC address is not required for V2X application. The THEO-P173 serial number can be used as a unique MAC address if the modules are configured to operate in IEEE 802.11a networks.

Advance Information

2 Host interfaces

2.1 USB interface

THEO-P173 module supports a USB 2.0 high-speed interface. The THEO-P173 module uses the USB interface for firmware loading (booting) and high speed data transfer (> 200 Mbps). The USB interface of the module is powered with 3.3 V supply voltage. The module acts as a device on the USB bus.



See *THEO-P173 System Integration Manual [2]* for more information about the USB interface.

2.2 SPI interface

The THEO-P173 does not support an SPI interface for booting and data transfer.



Contact u-blox support for your area, as listed in the Contact section for more information.

3 Pin definition

3.1 Pin assignment

The pin definition for the THEO-P173 module is provided in Figure 2. All pins marked as NC or begin with “#” should be soldered for mechanical strength with no further electrical connections.

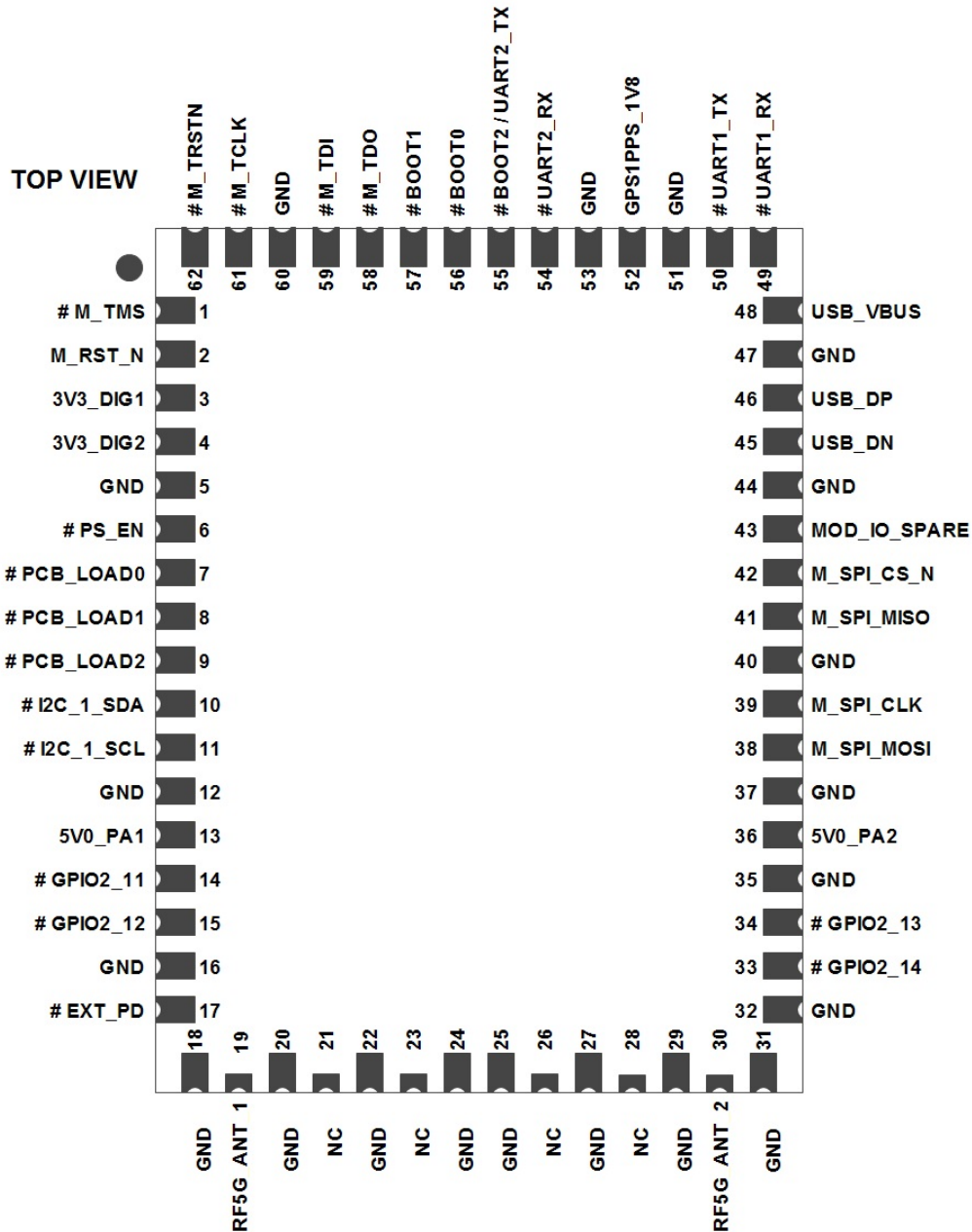

Figure 2: THEO-P173 pin assignment - Transparent top view

Pin	Assignment	Pin direction	Description	Remarks
1	# M_TMS		JTAG TMS	Leave unconnected
2	M_RST_N	I	Module Reset (1.8V) ²	
3	3V3_DIG1	P	3.3V Power Supply	
4	3V3_DIG2	P	3.3V Power Supply	
5	GND	P	Ground	
6	# PS_EN		This pin is internally pulled to pin 3 and 4, the 3.3V supply lines. This should not be shorted or pulled to ground. See <i>THEO-P173 System Integration Manual [2]</i> .	
7	# PCB_LOAD0		Configuration pin	Leave unconnected
8	# PCB_LOAD1		Configuration pin	Leave unconnected
9	# PCB_LOAD2		Configuration pin	Leave unconnected
10	# I2C_1_SDA		I2C_1 SDA	Leave unconnected
11	# I2C_1_SCL		I2C_1 SCL	Leave unconnected
12	GND	P	Ground	
13	5V0_PA1	P	5.0 V Power Supply (RF Ant 1) ³	
14	# GPIO2_11		GPIO (baseband controller)	Leave unconnected
15	# GPIO2_12		GPIO (baseband controller)	Leave unconnected
16	GND	P	Ground	
17	# EXT_PD		ADC input	Leave unconnected
18	GND	P	Ground	
19	RF5G_ANT1	O	5.9 GHz RF Port (Ant 1)	
20	GND	P	Ground	
21	N/C			
22	GND	P	Ground	
23	N/C			
24	GND	P	Ground	
25	GND	P	Ground	
26	N/C			
27	GND	P	Ground	
28	N/C			
29	GND	P	Ground	
30	RF5G_ANT2	RF	5 GHz RF Port (Ant 2)	
31	GND	P	Ground	
32	GND	P	Ground	
33	# GPIO2_14		GPIO (baseband controller)	Leave unconnected
34	# GPIO2_13		GPIO (baseband controller)	Leave unconnected
35	GND	P	Ground	

² This pin should be driven by an open drain/collector device. It is internally pulled high to 3.3 V by 10 k. During reset, it should be below 0.2 V.

³ The 5V0_PAn pins should have bypass caps located at the pin. These are NOT connected internally and each supply is isolated to its own PA. Provide supply whenever the module main supply is powered.

Pin	Assignment	Pin direction	Description	Remarks
36	5V0_PA2	P	5.0 V Power Supply (RF Ant 2) ³	
37	GND	P	Ground	
38	M_SPI_MOSI	O	Module SPI Bus (1.8V) ⁴	
39	M_SPI_SCK	O	Module SPI Bus (1.8V) ⁴	
40	GND	P	Ground	
41	M_SPI_MISO	I	Module SPI Bus (1.8V) ⁴	
42	M_SPI_CS	O	Module SPI Bus (1.8V) ⁴	
43	MOD_IO_SPARE	O	General Purpose IO (1.8 V) ⁵	
44	GND	P	Ground	
45	M_USB_D_N	BI	Module USB Bus ⁶	
46	M_USB_D_P	BI	Module USB Bus ⁶	
47	GND	P	Ground	
48	M_USB_VBUS	P	Module USB Bus (5.0V) ⁶	
49	# UART1_RX		UART1 RX	Leave unconnected
50	# UART1_TX		UART1 TX	Leave unconnected
51	GND	P	Ground	
52	GPS_1PPS_1V8	I	1PPS Input (1.8v) ⁷	
53	GND	P	Ground	
54	# UART2_RX		UART2 RX	Leave unconnected
55	# BOOT2/UART2_TX		BOOT mode selection / UART2 TX	Leave unconnected
56	# BOOT0		BOOT mode selection	Leave unconnected
57	# BOOT1		BOOT mode selection	Leave unconnected
58	# M_TDO		JTAG TDO	Leave unconnected
59	# M_TDI		JTAG TDI	Leave unconnected
60	GND	P	Ground	
61	# M_TCLK		JTAG TCLK	Leave unconnected
62	# M_TRSTN		JTAG TRSTN	Leave unconnected

Table 2: THEO-P173 pin-out

Pin direction: P=Power I=Input O=Output BI=Bidirectional RF=Radio Frequency

⁴ The SPI bus is nominally an output on all modules. Internally, depending upon the version of module, there may be a flash memory on this bus. Direction of these lines may be swapped on some versions of the module depending upon customer requirements. Always check your modules' model and version with the *THEO-P173 System Integration Manual [2]*.

⁵ This line is optionally a SPI CS line. In other cases, it may be used as a GPIO. Please check the model number against HW documentation for information on how to use this pin in your application.

⁶ The USB interface is only between the module and host processor for short impedance controlled traces. The data and VBUS signals should be applied to these pins only when the module has power applied otherwise damage may occur.

⁷ This input, as with all inputs, should not be driven in to the device when the power is not supplied to the module. Otherwise damage will occur. Contact u-blox support for your area for further information.

4 Electrical specification

Stressing the device above one or more of the ratings listed in the Absolute Maximum Rating section may cause permanent damage. These are stress ratings only. Operating the module at these or at any conditions other than those specified in the Operating conditions section of this document should be avoided. Exposure to absolute maximum rating conditions for extended periods may affect device reliability.

Operating condition ranges define those limits within which the functionality of the device is guaranteed. Where application information is given, it is advisory only and does not form part of the specification.

4.1 Absolute maximum ratings

Symbol	Description	Min.	Max.	Units
3V3_DIG1 3V3_DIG2	Power supply voltage 3.3 V	-0.3	3.9	V
5V0_PA1 5V0_PA2	Power supply voltage 5.0 V	-0.3	6.0	V
T _{STORAGE}	Storage temperature	-40	+85	°C

Table 3: Absolute maximum ratings

The product is not protected against overvoltage or reversed voltages. If necessary, voltage spikes exceeding the power supply voltage specification, given in table above, must be limited to values within the specified boundaries by using appropriate protection devices.

4.2 Operating conditions

Symbol	Parameter	Min.	Typ	Max.	Units
3V3_DIG1 3V3_DIG2	Power supply voltage 3.3 V	3.0	3.3	3.6	V
5V0_PA1 5V0_PA2	Power supply voltage 5.0 V	4.5	5.0	5.5	V
T _A	Ambient operating temperature	-40	-	+85	°C
Ripple Noise	Peak-to-peak voltage ripple on 3V3_DIGx and 5V0_PAx supply lines.	-	-	TBD	mV

Table 4: Operating conditions

4.3 Digital pad ratings

Symbol	Parameter	Conditions	Min.	Max.	Units
V _{IH}	Input high voltage		0.8*1V8	1V8+0.3	V
V _{IL}	Input low voltage		-0.3	0.3*1V8	V
V _{HYS}	Input hysteresis		180	-	mV
V _{OH}	Output high voltage	I _O max = 5 mA	1V8-0.4	-	V
V _{OL}	Output low voltage	I _O max = -5 mA	-	0.4	V

Table 5: Digital pad ratings

4.4 Peak power consumption

Operation Mode			Peak current ⁸ (mA)		
			3V3_DIG1 + 3V3_DIG2	5V0_PA1	5V0_PA2
RX	5.9 GHz		700 mA	0	0
TX	5.9 GHz	+23 dBm	700 mA	500 mA	500 mA
		+15 dBm	700 mA	TBD	TBD
		+10 dBm	700 mA	TBD	TBD
		+0 dBm	700 mA	TBD	TBD

Table 6: Peak power consumption

4.5 Power consumption

Power consumption for different operation modes - TBD

⁸ Peak values are shown. The average current for full operation mode (not a power save mode) strongly depends on RX/TX time ratio and remains within the range between the peak values of RX and TX.

4.6 Radio specifications

The THEO-P173 modules support 802.11p in the 5.9 GHz band. The radio specifications for THEO-P173 modules are provided in the table below.

Parameter	Operation Mode		Specification	
RF Frequency Range	802.11p		5.85 – 5.925 GHz	
Modulation	802.11p		OFDM	
Supported Data Rates	802.11p		3, 4.5, 6, 9, 12, 18, 24, 27 Mbps	
Supported Bandwidth	802.11p		10 MHz	
Maximum Transmit Power	802.11p		23 dBm ± 2 dB	
Minimum Transmit Power	802.11p		-10 dBm	
Receiver sensitivity	802.11p	10 MHz, no multipath, 25 °C	3 Mbps	-98 dBm typ., -95 dBm min.
			4.5 Mbps	-96 dBm typ., -93 dBm min.
			6 Mbps	-95 dBm typ., -92 dBm min.
			9 Mbps	-93 dBm typ., -90 dBm min.
			12 Mbps	-90 dBm typ., -87 dBm min.
			18 Mbps	-86 dBm typ., -83 dBm min.
			24 Mbps	-82 dBm typ., -79 dBm min.
	10 MHz, NLoS (Non-line-of-sight), 25 °C	3 Mbps	-95 dBm typ., -92 dBm min.	
		4.5 Mbps	-92 dBm typ., -89 dBm min.	
		6 Mbps	-88 dBm typ., -85 dBm min.	
		9 Mbps	-86 dBm typ., -83 dBm min.	
		12 Mbps	-85 dBm typ., -82 dBm min.	
		18 Mbps	-82 dBm typ., -79 dBm min.	
		24 Mbps	na	
27 Mbps	na			
Receiver maximum operating input level	802.11p		-20 dBm	
RSSI accuracy	802.11p		Over temperature range	+/-2 dB
Centre frequency and symbol clock tolerance	802.11p		+/-10 ppm	
Transmitter spectral flatness	802.11p		All modulation modes	< +/-2 dB
Transmitter centre frequency leakage	802.11p		< -15 dB	
Transmit power control step size	802.11p		0.5 dB	
Transmit power control accuracy	802.11p		Over temperature range	+/-2 dB

Table 7: Radio specifications

Table 8 shows the Highway NLoS (Non-line-of-sight) channel parameters that are used to obtain the receiver sensitivity values in Table 7. This channel was used in RF testing at the third ETSI Plug test (CMS3).

Each tap is faded using Pure Doppler, but the second antenna has a Doppler increased by 11 Hz, which prevents phase synchronization of channels. The RX Power listed in Table 7 refers to the power of Tap 0.

The values presented are typical values, measured at +25 °C.

Tap#	Relative Power (dB)	Delay (ns)	Doppler Frequency (Hz)
0	0	0	0
1	-2	200	689
2	-5	433	-492
3	-7	700	886

Table 8: Highway NLoS channel parameters

The adjacent and non-adjacent channel rejection measurements are provided in Table 9 and Table 10 respectively.

Bit rate	Target ACR (dB)	Target opt. enc. ACR (dB)	THEO-P173 typical ACR (dB)
3 Mbps (1/2BPSK)	16	28	37
4.5 Mbps (3/4BPSK)	15	27	33
6 Mbps (1/2QPSK)	13	25	35
9 Mbps (3/4QPSK)	11	23	29
12 Mbps (1/2QAM16)	8	20	29
18 Mbps (3/4QAM16)	4	16	25
24 Mbps (2/3QAM64)	0	12	22
27 Mbps (3/4QAM64)	-1	11	20

Table 9: Adjacent channel rejection

Bit rate	Target ACR (dB)	Target opt. enc. ACR (dB)	THEO-P173 typical ACR (dB)
3 Mbps (1/2BPSK)	32	42	51
4.5 Mbps (3/4BPSK)	31	41	48
6 Mbps (1/2QPSK)	29	39	48
9 Mbps (3/4QPSK)	27	37	45
12 Mbps (1/2QAM16)	24	34	42
18 Mbps (3/4QAM16)	20	30	38
24 Mbps (2/3QAM64)	16	26	34
27 Mbps (3/4QAM64)	15	25	32

Table 10: Non-adjacent channel rejection

4.7 Example circuit

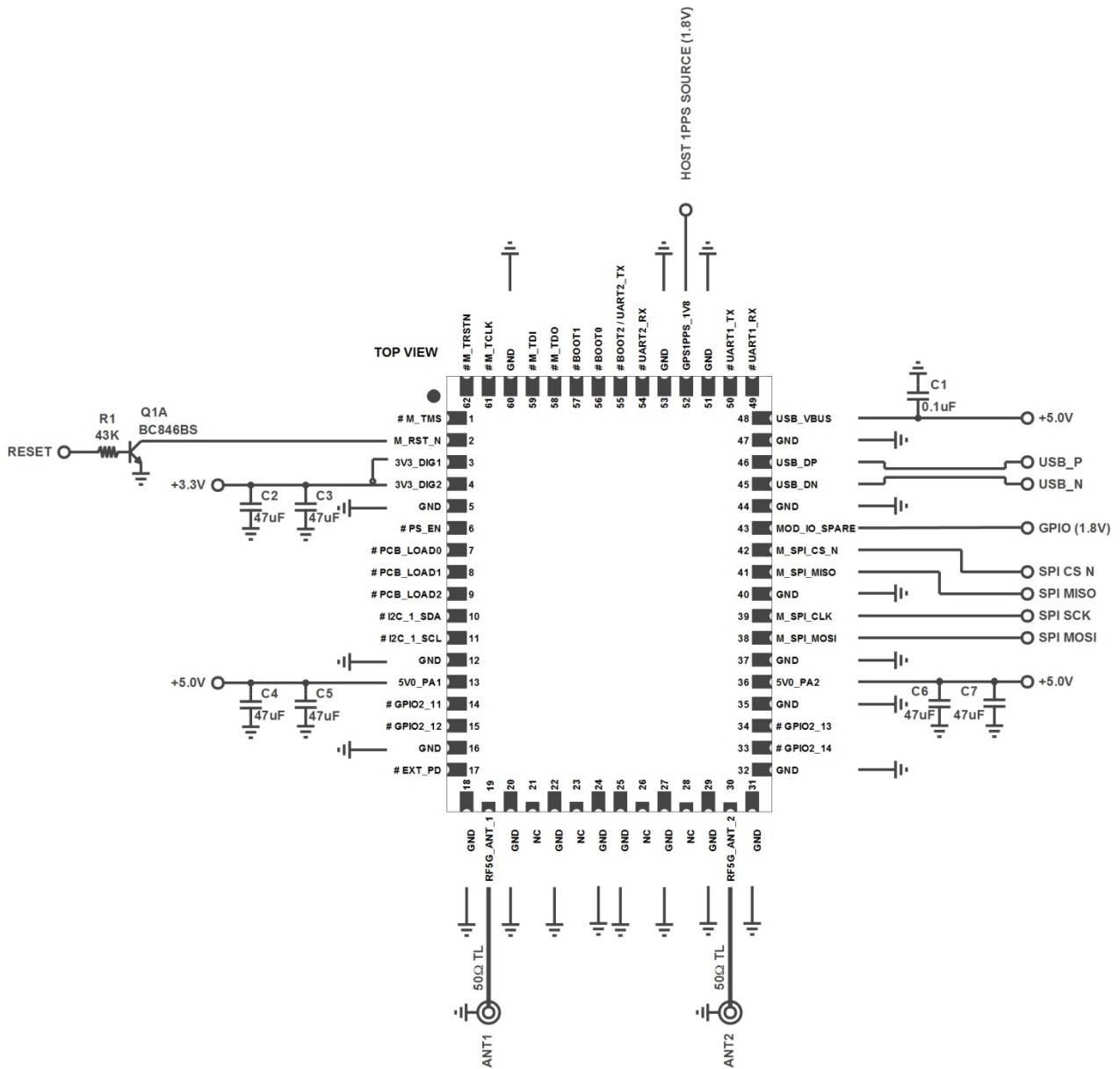

Figure 3: Example circuit around THEO-P173 module

Designator	Part description	Manufacturer	Manufacturer Part #
C1	CAP CER .1UF 16V X7R 0402	Murata	GRM155R71C104KA88D
C2, C3, C4, C5, C6, C7	CAP CER 47uF 10V X5R 1206 +/-20%	Taiyo Yuden	LMK316BJ476ML-T
R1	RES CHIP 43k OHM 1/16W 0402 +/-1%	Yageo	RC0402FR-0743KL
Q1A	TRANS NPN/NPN BC846BS,115 NXP SOT363	NXP	BC846BS

Table 11: Example circuit Bill of Materials

5 Environmental specification

The performance of the THEO-P173 module will be valid over a temperature range of -40 °C to +85 °C (PCB ambient temperature). Table 12 provides a summary of the environmental requirements for the THEO-P173 module.

Item	Standard
Vibration	ISO 16750
Mechanical shock	DIN EN 60068
Damp heat	IEC 60068
Drop test	ISO16750-3:2007 DIN EN 60068-2-32:1995

Table 12: THEO-P173 module environmental requirements

6 Mechanical specifications

6.1 Dimensions

The physical dimension of the THEO-P173 module is provided in Figure 4. The module is a rectangular unit with dimensions of 30.0 mm x 40.0 mm and a height of approximately 4.0 mm.

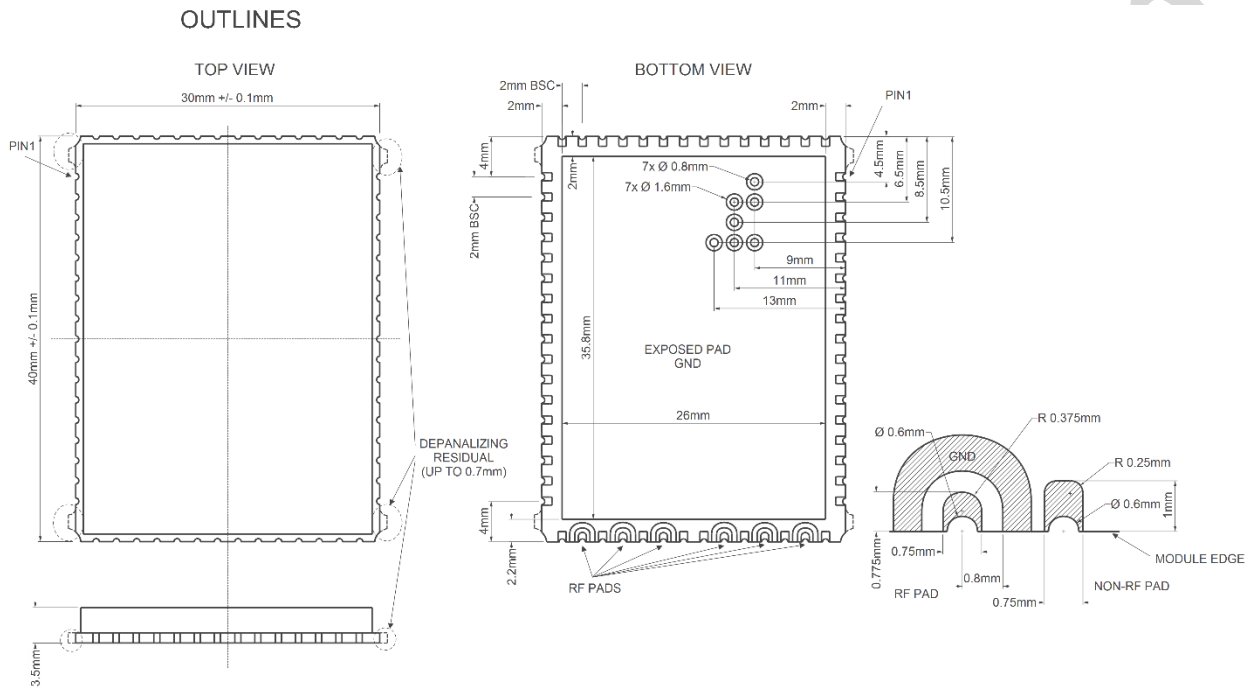

Figure 4: Physical dimensions of THEO-P173

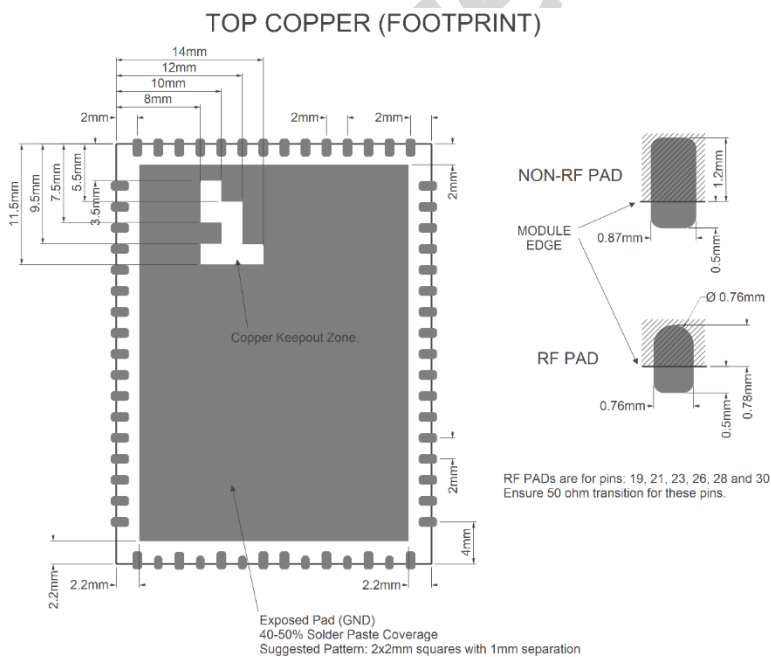

Figure 5: Recommended footprint

7 Qualification and approvals

7.1 Approvals



Products marked with this lead-free symbol on the product label comply with the "Directive 2002/95/EC of the European Parliament and the Council on the Restriction of Use of certain Hazardous Substances in Electrical and Electronic Equipment" (RoHS).

THEO-P173 transceiver modules are RoHS compliant.

7.1.1 FCC compliance

The THEO-P173 module complies with Part 15 of the FCC Rules. Operation is subject to the following two conditions:

1. This device may not cause harmful interference, and
2. This device must accept any interference received, including interference that may cause undesired operation.

Non authorized modification could void authority to use this equipment. The internal / external antenna(s) used for this module must provide a separation distance of at least 20 cm from all persons and must not be co-located or operating in conjunction with any other antenna or transmitter.

These limits are designed to provide reasonable protection against harmful interference in a residential installation. This equipment generates, uses and can radiate radio frequency energy and, if not installed and used in accordance with the manufacturer's instructions, may cause harmful interference to radio communications.



The outside of final product that contains the THEO-P173 module must display in a user accessible area a label referring to the enclosed module. This exterior label can use wording such as the following: "Contains Transmitter Module FCC ID: XPYTHEOP173" or "Contains FCC ID: XPYTHEOP173".

7.2 FCC ID

Model name	FCC ID
THEO-P173	XPYTHEOP173

Table 13: FCC ID for THEO-P173

8 Product handling

8.1 Packaging

The THEO-P173 modules are delivered on trays. For more information about packaging, see the *u-blox Package Information Guide [1]*.

8.2 Shipment, storage and handling

For more information regarding shipment, storage and handling see the *u-blox Package Information Guide [1]*.

8.2.1 Moisture sensitivity levels

 **The THEO-P173 modules are Moisture Sensitive Devices (MSD) in accordance with the IPC/JEDEC specification.**

The Moisture Sensitivity Level (MSL) relates to the required packaging and handling precautions. The THEO-P173 modules are rated at moisture sensitivity level 4. See the *u-blox Package Information Guide [1]* for more information regarding moisture sensitivity levels, labeling, and storage.



For MSL standard, see IPC/JEDEC J-STD-020, which can be downloaded from www.jedec.org.

8.2.2 Mounting process and soldering recommendations

The castellated edges of the THEO-P173 module shall be individually soldered to the host board. A visual inspection after reflow should allow for immediate confirmation whether the solder was successful. Solder mask and reflow profiles are explained in the *THEO-P173 System Integration Manual [2]*.

8.2.3 ESD handling precautions

 **THEO-P173 modules are Electrostatic Sensitive Devices (ESD). Observe precautions for handling! Failure to observe these precautions can result in severe damage to the Wi-Fi receiver!**

Wi-Fi transceivers are Electrostatic Sensitive Devices (ESD) and require special precautions when handling. Particular care must be exercised when handling patch antennas, due to the risk of electrostatic charges. In addition to standard ESD safety practices, the following measures should be taken into account whenever handling the receiver:

- Unless there is a galvanic coupling between the local GND (i.e. the work table) and the PCB GND, then the first point of contact when handling the PCB must always be between the local GND and PCB GND.
- Before mounting an antenna patch, connect ground of the device.
- When handling the RF pin, do not come into contact with any charged capacitors and be careful when contacting materials that can develop charges (e.g. patch antenna ~10 pF, coax cable ~50-80 pF/m, soldering iron, ...)
- To prevent electrostatic discharge through the RF input, do not touch any exposed antenna area. If there is any risk that such exposed antenna area is touched in non ESD protected work area, implement proper ESD protection measures in the design.
- When soldering RF connectors and patch antennas to the receiver's RF pin, make sure to use an ESD safe soldering iron (tip).



9 Labeling and ordering information

9.1 Product labeling

The labels of THEO-P173 include important product information as described in this section. The data matrix code includes a serial number.

Figure 6 illustrates the sample label of THEO-P173 and includes: pin1 marking, u-blox logo, product name (model), type number, serial number, FCC certification number and date of unit production encoded YYWW (year/week).

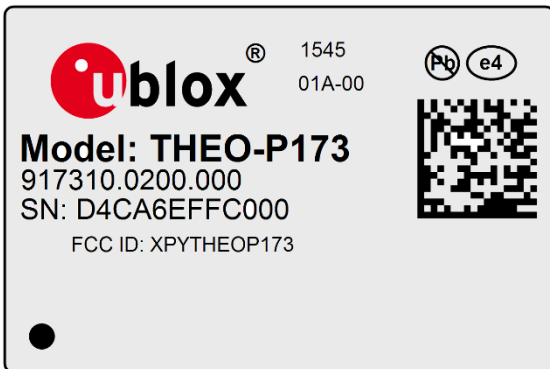

Figure 6: THEO-P173 – Sample label

9.2 Explanation of codes

Two different product code formats are used. The **Product Name** is used in documentation such as this data sheet and identifies all u-blox products, independent of packaging and quality grade. The **Ordering Code** includes options and quality, while the **Type Number** includes the hardware and firmware versions. Table 14 below details these three different formats:

Format	Structure
Product Name	PPPP-TGVV
Ordering Code	PPPP-TGVV-TTQ
Type Number	PPPP-TGVV-TTQ-XX

Table 14: Product code formats

Table 15 explains the parts of the product code.

Code	Meaning	Example
PPPP	Form factor	THEO
TG	Platform T – Dominant technology, For example, W: Wi-Fi, B: Bluetooth G – Generation	P1
VV	Variant based on the same platform; range [00...99]	73
TT	Major Product Version	00
Q	Quality grade A: Automotive B: Professional C: Standard	A
XX	Minor product version (not relevant for certification)	00

Table 15: Part identification code

9.3 Ordering codes

Ordering Code	Product name	Product
THEO-P173-01A	THEO-P173	THEO-P173 module

Table 16: Product ordering code



Product changes affecting form, fit or function are documented by u-blox. For a list of Product Change Notifications (PCNs) see our website.

Advance Information

Appendix

A Glossary

Name	Definition
CS	Chip select
DSRC	Dedicated Short-Range Communications
ESD	Electrostatic Sensitive Devices
ETSI	European Telecommunications Standards Institute
EVM	Earned Value Management
FCC	Federal Communications Commission
GPIO	General-purpose input/output
HD	High Definition
IC	Industry Canada
IEEE	Institute of Electrical and Electronics Engineers
ITS	Intelligent Transport Systems
LLC	Logical Link Control
MAC	Media Access Control
nACR	Non-adjacent channel rejection
NLoS	Non Line of Sight
OBU	On Board Unit
OFDM	Orthogonal frequency-division multiplexing
PCB	Printed Circuit Board
PER	Packet error rate
PPS	Pulse per second
PSDU	PLCP service data unit
RF	Radio Frequency
RoHS	Restriction of Hazardous Substances
SAR	Specific absorption rate
SPI	Serial Peripheral Interface
USB	Universal Serial Bus
UTC	Coordinated Universal Time
V2X	Vehicle-to-Everything

Table 17: Explanation of abbreviations and terms used

Related documents

- [1] u-blox Package Information Guide, document number UBX-14001652
- [2] THEO-P173 System Integration Manual, document number UBX-15029954



For regular updates to u-blox documentation and to receive product change notifications please register on our homepage.

Revision history

Revision	Date	Name	Status / Comments
R01	8-Feb-2016	vdyk, kgom	Converted version 1.5 of the CohdaMobility MK5 Module Data Sheet to u-blox THEO-P1 Data Sheet. Product name changed from Cohda MK5 to THEO-P1. Initial release.
R02	30-Nov-2016	este, kgom	Updated Figure 3. Changed the product name as "THEO-P173" and the product grade as Professional. Modified Table 1.

Contact

For complete contact information visit us at www.u-blox.com.

u-blox Offices

North, Central and South America

u-blox America, Inc.

Phone: +1 703 483 3180
E-mail: info_us@u-blox.com

Regional Office West Coast:

Phone: +1 408 573 3640
E-mail: info_us@u-blox.com

Technical Support:

Phone: +1 703 483 3185
E-mail: support_us@u-blox.com

Headquarters Europe, Middle East, Africa

u-blox AG

Phone: +41 44 722 74 44
E-mail: info@u-blox.com
Support: support@u-blox.com

Asia, Australia, Pacific

u-blox Singapore Pte. Ltd.

Phone: +65 6734 3811
E-mail: info_ap@u-blox.com
Support: support_ap@u-blox.com

Regional Office Australia:

Phone: +61 2 8448 2016
E-mail: info_au@u-blox.com
Support: support_ap@u-blox.com

Regional Office China (Beijing):

Phone: +86 10 68 133 545
E-mail: info_cn@u-blox.com
Support: support_cn@u-blox.com

Regional Office China (Chongqing):

Phone: +86 23 6815 1588
E-mail: info_cn@u-blox.com
Support: support_cn@u-blox.com

Regional Office China (Shanghai):

Phone: +86 21 6090 4832
E-mail: info_cn@u-blox.com
Support: support_cn@u-blox.com

Regional Office China (Shenzhen):

Phone: +86 755 8627 1083
E-mail: info_cn@u-blox.com
Support: support_cn@u-blox.com

Regional Office India:

Phone: +91 80 4050 9200
E-mail: info_in@u-blox.com
Support: support_in@u-blox.com

Regional Office Japan (Osaka):

Phone: +81 6 6941 3660
E-mail: info_jp@u-blox.com
Support: support_jp@u-blox.com

Regional Office Japan (Tokyo):

Phone: +81 3 5775 3850
E-mail: info_jp@u-blox.com
Support: support_jp@u-blox.com

Regional Office Korea:

Phone: +82 2 542 0861
E-mail: info_kr@u-blox.com
Support: support_kr@u-blox.com

Regional Office Taiwan:

Phone: +886 2 2657 1090
E-mail: info_tw@u-blox.com
Support: support_tw@u-blox.com