

- **Drive Capability and Output Counts**
 - 80 mA (Current Sink) x 16 Bits
- **Constant Current Output Range**
 - 5 to 80 mA (Current Value Setting for All Output Terminals Using External Resistor and Internal Brightness Control Register)
- **Constant Current Accuracy**
 - $\pm 4\%$ (Maximum Error Between Bits)
- **Voltage Applied to Constant Current Output Terminals**
 - Minimum 0.4 V (Output Current 5 mA to 40 mA)
 - Minimum 0.7 V (Output Current 40 mA to 80 mA)
- **1024 Gray Scale Display**
 - Pulse Width Control 1024 Steps
- **Brightness Adjustment†**
 - All Output Current Adjustment for 64 Steps (Adjustment for Brightness Deviation Between LED Modules)
 - Output Current Adjustment by Output (OUT0 to OUT15) for 128 Steps (Adjustment for Brightness Deviation Between Dots)
 - Brightness Control by 16 Steps Frequency Division Gray Scale Control Clock (Brightness Adjustment for Panel)
- **Gray Scale Clock Generation**
 - Gray Scale Control Clock Generation by Internal PLL or External Input Selectable
- **Clock Invert/Noninvert Selectable at Cascade Operation**
 - Clock Invert Selectable to Reduce Changes in Duty Ratio
- **Protection**
 - Watchdog Timer (WDT) Function (Turn Output Off When Scan Signal Stopped)
 - Thermal Shutdown (TSD) Function (Turn Output Off When Junction Temperature Exceeds Limit)
- **LOD**
 - LED Open Detection (Detection for LED Disconnection)
- **Data Input/Output‡**
 - Port A (for Data Display)
 - Clock Synchronized 10 Bit Parallel Input (Schmitt-Triggered Input)
 - Clock Synchronized 10 Bit Parallel Output (3-State Output)
 - Port B (for Dot Correction Data)
 - Clock Synchronized 7 Bit Parallel Input (Schmitt-Triggered Input)
 - Clock Synchronized 7 Bit Parallel Output
- **Input/Output Signal Level**
 - CMOS Level
- **Power Supply Voltage**
 - 4.5 V to 5.5 V (Logic, Analog and Constant Current)
 - 3 V to 5.5 V (Interface)
- **Maximum Output Voltage . . . 15 V**
- **Data Transfer Rate . . . 20 MHz (Max)**
- **Gray Scale Clock Frequency**
 - 16 MHz (Max) Using Internal PLL
 - 8 MHz (Max) Using External Clock
- **Operating Free-Temperature Range**
 - -20°C to 85°C
- **100-Pin Package HTQFP ($P_D = 4.7\text{ W}$, $T_A = 25^{\circ}\text{C}$)**

† Adjustable for these functions independently.

‡ Allows to write all the data at port A by setting.



Please be aware that an important notice concerning availability, standard warranty, and use in critical applications of Texas Instruments semiconductor products and disclaimers thereto appears at the end of this data sheet.

PRODUCTION DATA information is current as of publication date. Products conform to specifications per the terms of Texas Instruments standard warranty. Production processing does not necessarily include testing of all parameters.

 **TEXAS
INSTRUMENTS**

POST OFFICE BOX 655303 • DALLAS, TEXAS 75265

Copyright © 1999, Texas Instruments Incorporated

TLC5911 LED DRIVER

SLLS402 – DECEMBER 1999

description

The TLC5911 is a constant current driver incorporating shift register, data latch, and constant current circuitry with a current value adjustable, PLL circuitry for gray scale control clock generation, and 1024 gray scale display using pulse width control. The output current is maximum 80 mA with 16 bits, and the current value of constant current output can be set by one external resistor. The device has two channel I/O ports. The brightness deviation between LED modules (ICs) can be adjusted by external data input from the display data port, and the brightness control for the panel can be accomplished by the brightness adjustment circuitry. Independent of these functions, the device incorporates the shift register and data latch to correct the deviation between LEDs by adjusting the output current using data from the dot correction data port. Moreover, the device incorporates WDT circuitry, which turns constant current output off when the scan signal stops during the dynamic scanning operation, and TSD circuitry, which turns constant current output off when the junction temperature exceeds the limit. Also the LED open detection (LOD) circuitry is used to make error signal output at the LED disconnection.

pin assignments

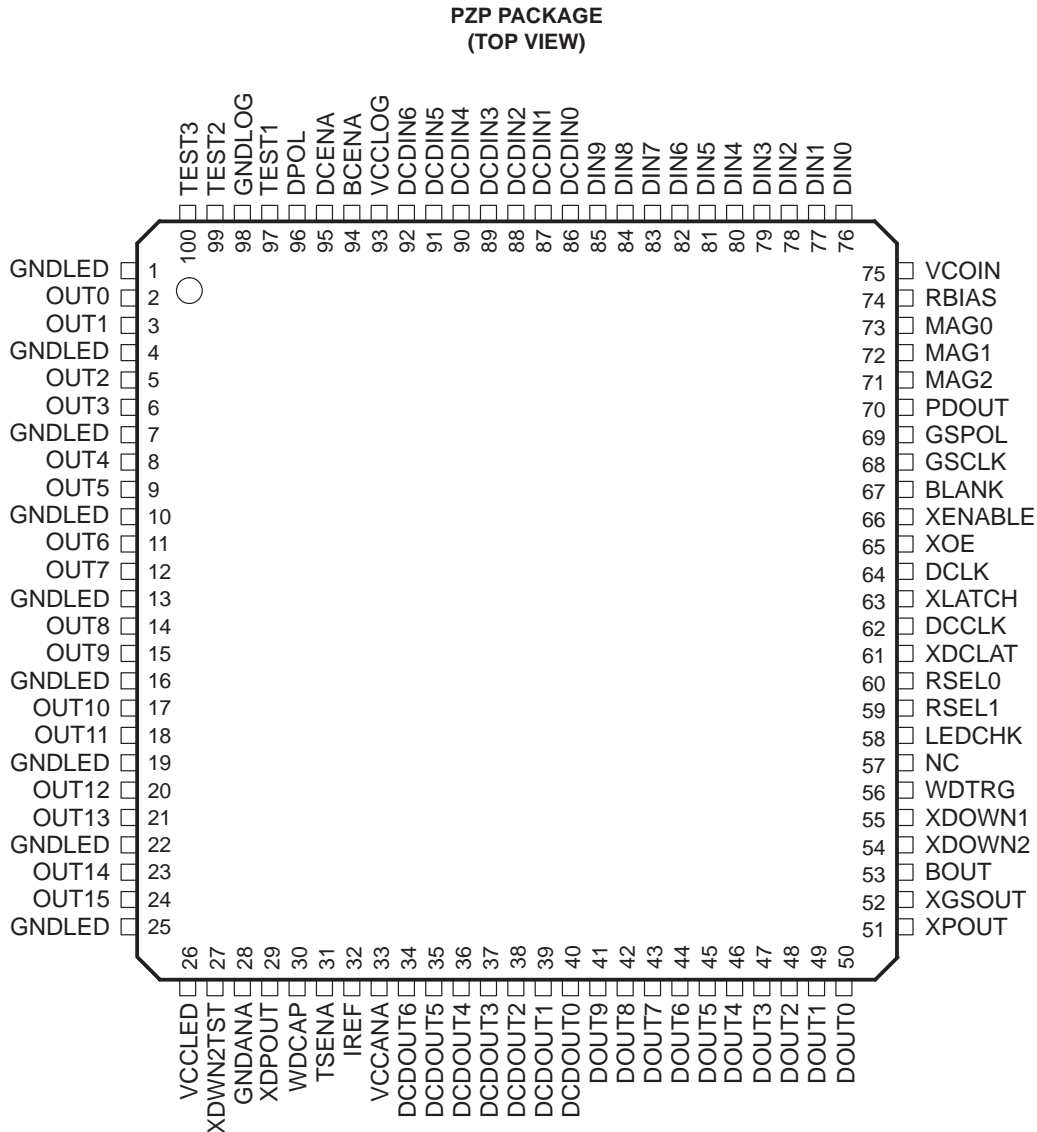

functional block diagram

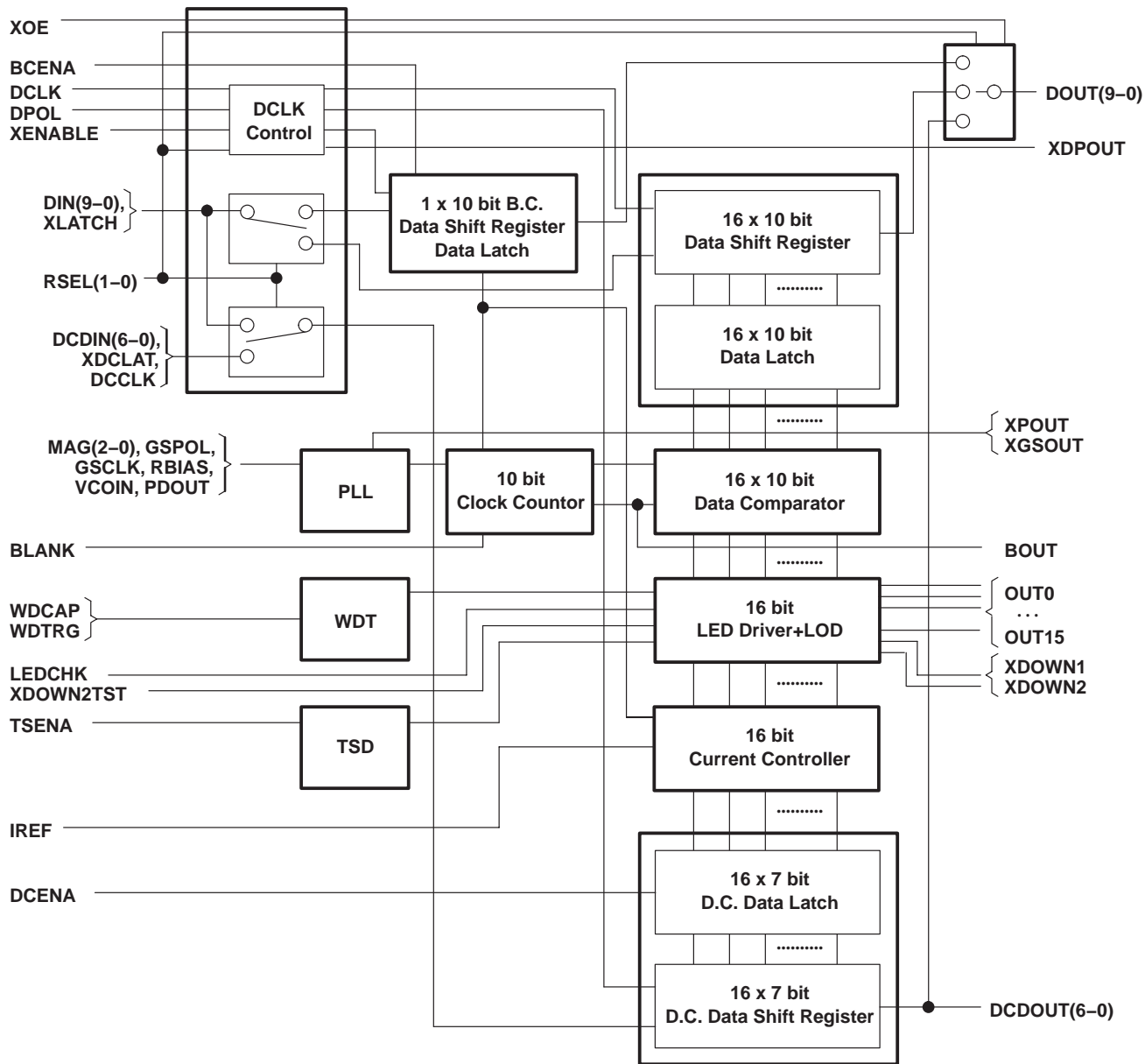

Legend:

B.C. (Brightness Control): Adjustment for brightness deviation between LED modules, and between panels.

D.C. (Dot Control): Adjustment for brightness deviation between dots.

NOTE: All the input terminals are with Schmitt triggered inverter except RBIAS, VCOIN, PDOUT, IREF and WDCAP.

TLC5911 LED DRIVER

SLLS402 – DECEMBER 1999

functional block diagram for shift register and data latch

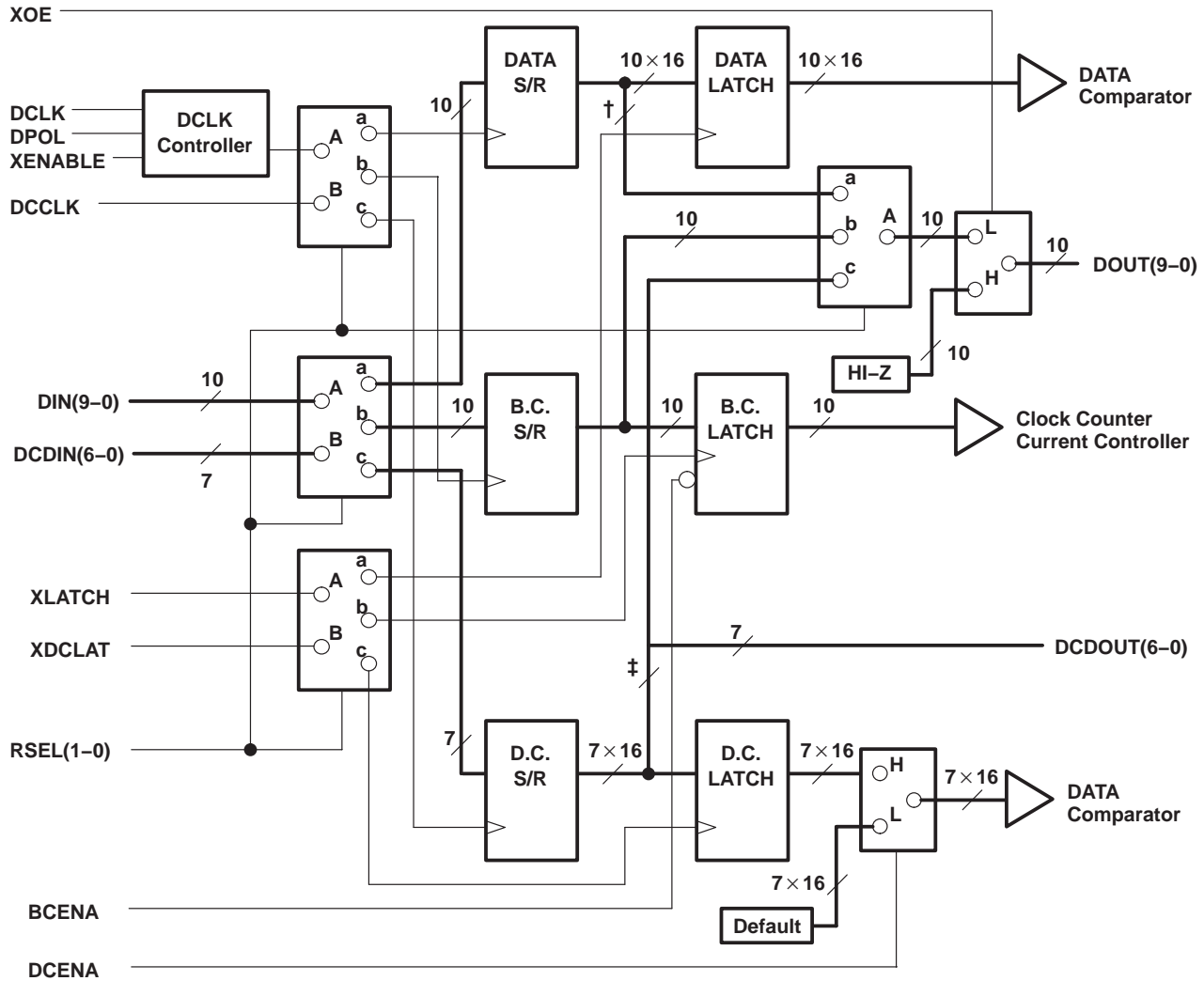

† Connecting to 16th 10-bit Bus

‡ Connecting to 16th 7-bit Bus

Legend:

B.C. (Brightness Control): Adjustment for brightness deviation between LED modules, and between panels.

D.C. (Dot Control): Adjustment for brightness deviation between dots.

RSEL		CONNECTION
RSEL1	RSEL0	
L	L	A - a, B - c
L	H	A - b, B - c
H	L	A - c
H	H	INHIBIT

equivalent input and output schematic diagrams

Input

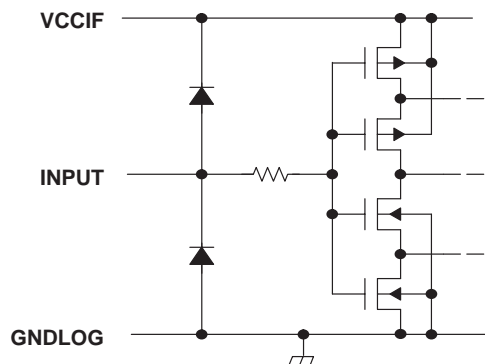

DOUT0–9, DCDOUT0–6, XGSOUT, XPOUT, BOUT

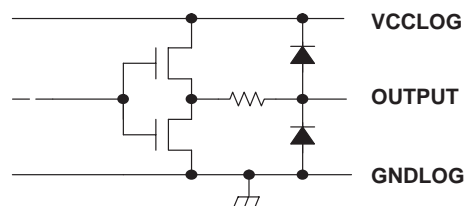

XDOWN1, XDOWN2

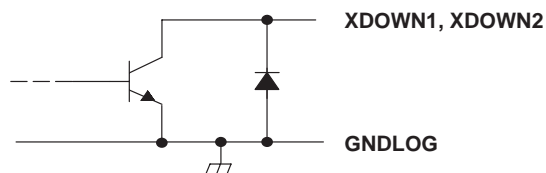

OUTn

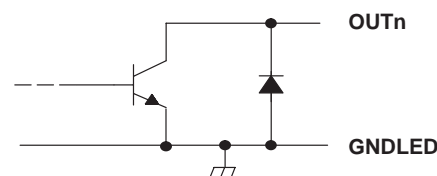

Terminal Functions

TERMINAL NAME	TERMINAL NO.	I/O	DESCRIPTION
BCENA	94	I	Brightness control enable. When BCENA is low, the brightness control latch is set to the default value. The output current value in this status is 100% of the value set by an external resistor. The frequency division ratio of GSCLK is 1/1. When BCENA is high, writing to brightness control latch is enabled.
BLANK	67	I	Blank (Light off). When BLANK is high, all output of the constant current driver are turned off. When GSPOL is high, all the output is turned on (LED on) synchronizing to the falling edge of GCLK after next rising edge of GSCLK when BLANK goes from high to low. When GSPOL is low, all the output is turned on (LED on) synchronizing to the rising edge of GCLK after next falling edge of GSCLK when BLANK goes from high to low.
BOUT	53	O	BLANK buffered output
DCCLK	62	I	Clock input for data transfer. The input data is from DCDIN (port B) . The output data at DCDOUT. All data on the shift register for dot correction data from DCDIN is shifted by 1 bit and is synchronized to the rising edge of DCCLK.
DCDIN0 – DCDIN6	86,87,88, 89,90,91,92	I	Input for 7 bit parallel data (port B). These terminals are used as shift register input for dot correction data.
DCDOUT0 – DCDOUT6	34,35,36, 37,38,39,40	O	Output for 7 bit parallel data (port B). These terminals are used as shift register output for dot correction data.
DCENA	95	I	Latch enable for dot correction data. When DCENA is low, the latch is set to the default value. At this time, the output current value is 100% of the value set by an external resistor.
DCLK	64	I	Clock input for data transfer. The input data is from DIN (port A) , all the data on the shift register selected by RSEL0, 1 and the output data at DOUT are shifted by 1 bit and synchronized to DCLK. Note that whether synchronizing to the rising or falling edge of DCLK is dependent on the value of DPOL.

TLC5911 LED DRIVER

SLLS402 – DECEMBER 1999

Terminal Functions (Continued)

TERMINAL NAME	NO.	I/O	DESCRIPTION
DIN0 – DIN9	76,77,78,79,80, 81,82,83,84,85	I	Input for 10 bit parallel data (port A). These terminals are inputs for shift register for gray scale data, brightness control, and dot correction data. The register selected is determined by RSEL0, 1.
DOUT0 – DOUT9	41,42,43,44,45, 46,47,48,49,50	O	Output for 10 bit parallel data (port A). These terminals are outputs for shift register for gray scale data, brightness control, and dot correction data. The register selected is determined by RSEL0, 1.
DPOL	96	I	Selects the valid edge of DCLK. When DPOL is high, the rising edge of DCLK is valid. When DPOL is low, the falling edge of DCLK is valid.
GNDANA	28		Analog ground (Internally connected to GNDLOG and GNDLED)
GNDLOG	98		Logic ground (Internally connected to GNDANA and GNDLED)
GNDLED	1,4,7,10,13, 16,19,22,25		LED driver ground (Internally connected to GNDANA and GNDLED)
GSCLK	68	I	Clock input for gray scale. When MAG0 through MAG2 are all low, GSCLK is used for pulse width control. When MAG0 through MAG2 are not low, GSCLK is used for PLL timing control. The gray scale display is accomplished by lighting the LED until the number of GSCLK or PLL clocks counted is equal to the data latched.
GSPOL	69	I	Select the valid edge of GSCLK. When GSPOL is high, the rising edge of GSCLK is valid. When GSPOL is low, the falling edge of GSCLK is valid.
IREF	32	I/O	Constant current value setting. LED current is set to the desired value by connecting an external resistor between IREF and GND. The 38 times current is compared to current across the external resistor sink on the output terminal.
LEDCHK	58	I	LED disconnection detection enable. When LEDCHK is high, the LED disconnection detection is enabled and XDOWN2 is valid. When LEDCHK is low, the LED disconnection detection is disabled.
MAG0 – MAG2	73,72,71	I	PLL multiple ratio setting. The clock frequency generated by PLL referenced to GSCLK is set .
NC	57		No internal connection
OUT0 – DOUT15	2,3,5,6,8,9,11, 12,14,15,17,18, 20,21,23,24	O	Constant current output
PDOUT	70	I/O	Resistor connection for PLL feedback adjustment
RBIAS	74	I/O	Resistor connection for PLL oscillation frequency setting
RSEL0 RSEL1	60 59	I	Input/output port selection and shift register data latch switching. When RSEL1 is low and RSEL0 is low, the gray scale data shift register latch is selected to port A, and the dot correction register latch is selected to port B. When RSEL1 is low and RSEL0 is high, the brightness control register latch is selected to port A, and the dot correction register latch is selected to port B. When RSEL1 is high and RSEL0 is low, the dot correction register latch is selected to port A and no register latch is selected to port B.
TEST1 – TEST3	97,99,100	I	TEST. Factory test terminal. These terminals should be connected to GND.
THERMAL PAD	Package bottom		Heat sink pad. This pad is connected to the lowest potential IC or thermal layer.
TSENA	31	I	TSD enable. When TSENA is high, TSD is enabled. When TSENA is low, TSD is disabled.
VCCANA	33		Analog power supply voltage
VCCLOG	93		Logic power supply voltage
VCCLED	26		LED driver power supply voltage
VCOIN	75	I/O	Capacitance connection for PLL feedback adjustment
WDCAP	30	I/O	WDT detection time adjustment. WDT detection time is adjusted by connecting a capacitor between WDCAP and GND. When WDCAP is directly connected to GND, the WDT function is disabled. In this case, WDTRG should be tied to high or low level.



POST OFFICE BOX 655303 • DALLAS, TEXAS 75265

Terminal Functions (Continued)

TERMINAL NAME	NO.	I/O	DESCRIPTION
WDTRG	56	I	WDT trigger input. By applying a scan signal to this terminal, the scan signal can be monitored by turning the constant current output off and protecting the LED from the damage of burning when the scan signal stops during the constant period designed.
XDCLAT	61	I	Data latch for dot correction. When XDCLAT is high, data on the shift register for dot correction data from DCDIN (port B) goes through latch. When XDCLAT is low, the data is latched. Accordingly, if data on the shift register is changed during XDCLAT high, the new value is latched (level latch).
XDOWN1	55	O	Shutdown. XDOWN1 is configured as open collector. It goes low when the constant current output is shut down by the WDT or TSD function.
XDOWN2	54	O	LED disconnection detection output. XDOWN2 is configured as open collector. XDOWN2 goes low when a LED disconnection is detected.
XDPOUT	29	O	DPOL output inverted
XDWN2TST	27	I	Test for XDOWN2. When XDWN2TST is low, XDOWN2 goes low. (This terminal is internally pulled up with 50 k Ω)
XENABLE	66	I	DCLK enable. When XENABLE is low, data transfer is enabled. Data transfer starts on the valid edge of DCLK after XENABLE goes low. During XENABLE high, no data is transferred.
XGSOUT	52	O	Clock output for gray scale. When MAG0 through MAG2 are all low, a clock with GSCLK inverted appears on this terminal. When MAG0 through MAG2 are not low., PLLCLK appears on this terminal.
XLATCH	63	I	Latch. When XLATCH is high, data on shift register from DIN (port A) goes through latch. When XLATCH is low, data is latched. Accordingly, if the data on the shift register is changed during XLATCH high, this new value is latched (level latch).
XOE	65	I	Data output enable. When XOE is low, the DOUT0–9 terminals are driven. When XOE is high, the DOUT0–9 terminals go to a high-impedance state.
XPOUT	51	O	GSPOL output inverted

TLC5911 LED DRIVER

SLLS402 – DECEMBER 1999

absolute maximum ratings over operating free-air temperature (unless otherwise noted)†

Logic supply voltage, $V_{CC(LOG)}$	– 0.3 V to 7 V
Supply voltage for constant current circuit, $V_{CC(LED)}$	– 0.3 V to 7 V
Analog supply voltage, $V_{CC(ANA)}$	– 0.3 V to 7 V
Output current (DC), $I_{OL(C)}$	85 mA
Input voltage range, V_I	– 0.3 V to $V_{CC(LOG)} + 0.3$ V
Output voltage range, $V_{(DOUT)}$, $V_{(DCDOUT)}$, $V_{(BOUT)}$, $V_{(XPOUT)}$ and $V_{(XGSOUT)}$	– 0.3 V to $V_{CC(LOG)} + 0.3$ V
Output voltage range, V_O and $V_{(XDOWNn)}$	– 0.3 V to 16 V
Storage temperature range, T_{str}	–40°C to 150°C
Continuous total power dissipation at (or below) $T_A = 25^\circ\text{C}$	4.7 W
Power dissipation rating at (or above) $T_A = 25^\circ\text{C}$	38.2m W/°C

† Stresses beyond those listed under “absolute maximum ratings” may cause permanent damage to the device. These are stress ratings only, and functional operation of the device at these or any other conditions beyond those indicated under “recommended operating conditions” is not implied. Exposure to absolute-maximum-rated conditions for extended periods may affect device reliability.

NOTE 1: All voltage values are with respect to GNDLOG terminal.

recommended operating conditions

dc characteristics

		MIN	NOM	MAX	UNIT
Logic supply voltage, $V_{CC(LOG)}$		4.5	5	5.5	V
Supply voltage for constant current circuit, $V_{CC(LED)}$		4.5	5	5.5	V
Analog power supply, $V_{CC(ANA)}$		4.5	5	5.5	V
Voltage between V_{CC} , $V_{(DIFF1)}$	$V_{(DIFF1)} =$ $V_{CC(LOG)} - V_{CC(ANA)}$ $V_{CC(LOG)} - V_{CC(LED)}$ $V_{CC(ANA)} - V_{CC(LED)}$	–0.3	0	0.3	V
Voltage between GND, $V_{(DIFF2)}$	$V_{(DIFF2)} =$ $GND(LOG) - GND(ANA)$ $GND(LOG) - GND(LED)$ $GND(ANA) - GND(LED)$	–0.3	0	0.3	V
Voltage applied to constant current output, V_O	OUT0 to OUT15 off			15	V
High-level input voltage, V_{IH}		$0.8 V_{CC(LOG)}$		$V_{CC(LOG)}$	V
Low-level input voltage, V_{IL}		$GND(LOG)$		$0.2 V_{CC(LOG)}$	V
High-level output current, I_{OH}	$V_{CC(LOG)} = 4.5$ V, DOUT0 to DOUT9, DCDOUT0 to DCDOUT5, BOUT, XGSOUT, XPOUT			–1	mA
Low-level output current, I_{OL}	$V_{CC(LOG)} = 4.5$ V, DOUT0 to DOUT9, DCDOUT0 to DCDOUT5, BOUT, XGSOUT, XPOUT			1	
	$V_{(CCLOG)} = 4.5$ V, XDOWN1, XDOWN2			5	mA
Constant output current, $I_{OL(C)}$	OUT0 to OUT15	5		80	mA
Operating free-air temperature range, T_A		–20		85	°C
PLL capacitance, $C_{(VCO)}$			1		μF
PLL resistor, $R_{(BIAS)}$	At 16 MHz oscillation		22		kΩ
PLL resistor, $R_{(PD)}$			30		kΩ



recommended operating conditions (continued)

ac characteristics, $V_{CC(LO)} = V_{CC(ANA)} = V_{CC(LED)} = 4.5\text{ V to }5.5\text{ V}$, $T_A = -20\text{ to }85^\circ\text{C}$ (unless otherwise noted)

		MIN	TYP	MAX	UNIT
DCLK, DCCLK clock frequency, $f_{(DCLK)}/f_{(DCCLK)}$	At single operation			20	MHz
	At cascade operation			15	
DCLK, DCCLK pulse duration (high- or low-level), $t_{w(h)}/t_{w(l)}$		20			ns
GSCLK clock frequency, $f_{(GSCLK)}$				8	MHz
GSCLK pulse duration (high- or low-level), $t_{w(h)}/t_{w(l)}$		40			ns
PLLCLK clock frequency, $f_{(PLLCLK)}$				16	MHz
WDT clock frequency, $f_{(WDT)}$				8	MHz
WDT pulse duration (high- or low-level), $t_{w(h)}/t_{w(l)}$		40			ns
XLATCH, XDCLAT pulse duration (high-level), $t_{w(h)}$		30			ns
Rise/fall time, t_r/t_f				100	ns
Setup time, t_{su}	DINn – DCLK	5			ns
	DCDINn – DCCLK	5			
	BLANK – GSCLK	10			
	XENABLE – DCLK	15			
	XLATCH – DCLK	10			
	XLATCH – GSCLK	10			
	XDCLAT – DCCLK	10			
	RSEL – DCLK	10			
	RSEL – DCCLK	15			
RSEL – XLATCH	30				
RSEL – XDCLAT	15				
Hold time, t_h	DINn – DCLK	15			ns
	DCDINn – DCCLK	15			
	XENABLE – DCLK	20			
	XLATCH – DCLK	30			
	XDCLAT – DCCLK	20			
	RSEL – DCLK	20			
	RSEL – DCCLK	20			
	RSEL – XLATCH	20			
	RSEL – XDCLAT	10			

TLC5911 LED DRIVER

SLLS402 – DECEMBER 1999

electrical characteristics, LEDCHK = L, MIN/MAX: $V_{CC(LO)} = V_{CC(ANA)} = V_{CC(LED)} = 4.5\text{ V to }5.5\text{ V}$,
 $T_A = -20\text{ to }85^\circ\text{C}$, TYP: $V_{CC(LO)} = V_{CC(ANA)} = V_{CC(LED)} = 5\text{ V}$, $T_A = 25^\circ\text{C}$ (unless otherwise noted)

PARAMETER		TEST CONDITIONS	MIN	TYP	MAX	UNIT
V_{OH}	High-level output voltage	$I_{OH} = -1\text{ mA}$, DOUTn, DCOUTn, XGSOUT, XPOUT, BOUT	$V_{CC(LO)}$ -0.5			V
V_{OL}	Low-level output voltage	$I_{OL} = 1\text{ mA}$, DOUTn, DCOUTn, XGSOUT, XPOUT, BOUT			0.5	V
		$I_{OL} = 5\text{ mA}$, XDOWN1, XDOWN2			0.5	
I_I	Input current	$V_I = V_{CC(LO)}$ or GND(LO)			± 1	μA
$I_{(LO)}$	Supply current (logic)	Input signal is static, TSENA = H, WDCAP = OPEN, No PLL is used			1	mA
		Input signal is static, TSENA = H, WDCAP = OPEN, PLL multiple ratio = 1042			3	
		Data transfer, DCLK = 20 MHz, GSCLK = 8 MHz, No PLL is used		35	45	mA
		Data transfer, DCLK = 20 MHz, GSCLK = 15 kHz, PLL multiple ratio = 1042		39	49	
$I_{(ANA)}$	Supply current (analog)	BLANK = L, $R_{(IREF)} = 1200\ \Omega$		6.5	8	mA
		BLANK = L, $R_{(IREF)} = 600\ \Omega$		13	15	
$I_{(LED)}$	Supply current (constant current driver)	LED turn off, $R_{(IREF)} = 1200\ \Omega$		12	20	mA
		LED turn off, $R_{(IREF)} = 600\ \Omega$		20	35	
		$V_O = 1\text{ V}$, $R_{(IREF)} = 1200\ \Omega$, all output bits turn on		12	20	
		$V_O = 1\text{ V}$, $R_{(IREF)} = 600\ \Omega$, all output bits turn on		20	35	
$I_{OL(C1)}$	Constant output current (includes error between bits)	$V_O = 1\text{ V}$, $V_{(IREF)} = 1.2\text{ V}$, $R_{(IREF)} = 1200\ \Omega$	35	40	45	mA
$I_{OL(C2)}$	Constant output current (includes error between bits)	$V_O = 0.7\text{ V}$, $V_{(IREF)} = 1.2\text{ V}$, $R_{(IREF)} = 600\ \Omega$	70	80	90	mA
$I_{OL(K)}$	Constant output leakage current	OUT0 to OUT15 ($V_{OUTn} = 15\text{ V}$)			0.1	μA
		XDOWN1, 2 ($V_{XDOWNn} = 15\text{ V}$)			1	μA
		DOUTn, DCOUTn ($V_{OUTn} = V_{CC(LO)}$ or GND)			1	μA
$\Delta I_{OL(C)}$	Constant output current error between bit	$V_{CC(LO)} = V_{CC(ANA)} = V_{CC(LED)}$, $V_O = 1\text{ V}$, $R_{(IREF)} = 600\ \Omega$, All output bits turn on		$\pm 1\%$	$\pm 4\%$	
$\Delta I_{OL(C1)}$	Changes in constant output current depend on supply voltage	$V_O = 1\text{ V}$, $R_{(IREF)} = 600\ \Omega$, $V_{(IREF)} = 1.2\text{ V}$		$\pm 1\%$	$\pm 4\%$	V
$\Delta I_{OL(C2)}$	Changes in constant output current depend on output voltage	$V_O = 1\text{ V to }3\text{ V}$, $R_{(IREF)} = 600\ \Omega$, $V_{(IREF)} = 1.2\text{ V}$, 1 bit output turn on		$\pm 1\%$	$\pm 3\%$	V
$T_{(tsd)}$	TSD detection temperature	Junction temperature	150	160	170	$^\circ\text{C}$
$T_{(wdt)}$	WDT detection temperature	No external capacitor	5	10	15	ms
$V_{(IREF)}$	Voltage reference	BCENA = L, $R_{(IREF)} = 9.6\text{ k}\Omega$		1.2		V
$V_{(LEDDT)}$	Voltage applied to LED disconnection detection		0.2	0.3	0.4	V
$P_{(LLJITTER)}$	PLL jitter	$R_{(BIAS)} = 22\text{ k}\Omega$, $R_{(PD)} = 30\text{ k}\Omega$, $C_{(VCO)} = 0.1\ \mu\text{F}$		0.4%	2%	



switching characteristics, $C_L = 15 \text{ pF}$, MIN/MAX: $V_{CC(LOG)} = V_{CC(ANA)} = V_{CC(LED)} = 4.5 \text{ V to } 5.5 \text{ V}$, $T_A = -20 \text{ to } 85^\circ\text{C}$, TYP: $V_{CC(LOG)} = V_{CC(ANA)} = V_{CC(LED)} = 5 \text{ V}$, $T_A = 25^\circ\text{C}$ (unless otherwise noted)

PARAMETER	TEST CONDITIONS	MIN	TYP	MAX	UNIT
t_r Rise time	DOUTn, DCDOUn		12	30	ns
	XGSOUT, BOUT, XPOUT		12	30	
	OUTn (see Figure 1)		110		
t_f Fall time	DOUTn, DCDOUn		10	30	ns
	XGSOUT, BOUT, XPOUT		10	30	
	OUTn (see Figure 1)		130		
t_d Propagation delay time	OUTn+1 – OUTn		30	45	ns
	BLANK \uparrow – OUT0	40	50	70	
	BLANK – BOUT	10	20	40	
	GSCLK – OUT0 (see Note 2)		7		
	GSCLK – XGSOUT	10	20	40	
	DCLK – DOUTn	15	30	45	
	DCLK – DCDOUn	15	30	45	
	DCCLK – DCDOUn	15	30	45	
	XOE \downarrow – DOUTn (see Note 3)	10	20	35	
	XOE \uparrow – DOUTn (see Note 3)	10	15	25	
RSEL – DOUTn	10	20	40		
LEDCHK – XDOWN2			1000		

- NOTES: 2. MAG0 to MAG2 are all low level.
3. Until DOUT is turned on (drive) or turned off (Hi-Z).

PARAMETER MEASUREMENT INFORMATION

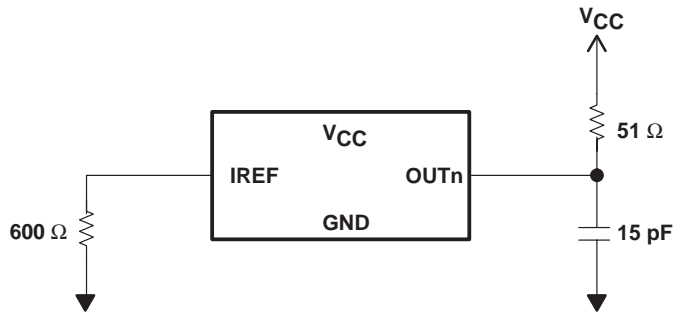

Figure 1. Rise Time and Fall Time Test Circuit for OUTn

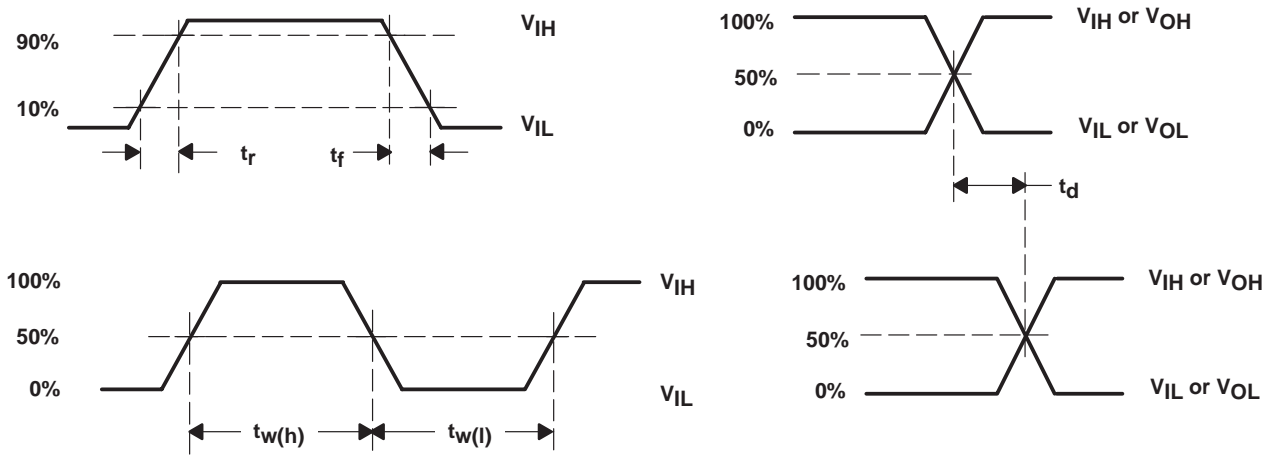

Figure 2. Timing Requirements

PRINCIPLES OF OPERATION

setting for output constant current value

On the constant current output terminals (OUT0–15), approximately 38 times the current which flows through the external resistor, $R_{(IREF)}$ (connected between IREF and GND), can flow. The external resistor value is calculated using the following equation:

$$R_{(IREF)} (\Omega) \cong 38 \times 1.2 (V) / I_{OL(C)}(A) \text{ where both BCENA and DCENA are low.}$$

Note that more current flows if IREF is connected to GND directly.

constant output current operation

The constant current output turns on (sink constant current), if GSPOL is high and if all the gray scale data latched into the gray scale latch is not zero on the falling edge of the gray scale clock after the next rising edge of the gray scale clock when BLANK goes from high to low. After that, the number of the falling edge is counted by the 10-bit gray scale counter. Then, the output counted corresponding to the gray scale data is turned off (stop to sink constant current). The gray scale clock can be selected, as discussed in later section, from GSCLK or by internal PLL circuitry. If the shift register for the gray scale is updated during XLATCH high, the data on the gray scale data latch is also updated affecting the number of the gray scale of constant current output. Accordingly, during the on-state of the constant current output, XLATCH should be kept at a low level and the gray scale data latch should be held.

input/output port and shift register selection

The TLC5911 supplies two parallel input ports such as DIN (10 bits : port A) and DCDIN (7 bits: port B). The DIN and DCDIN ports also supply DCLK and DCCLK for the shift clock, XLATCH and XDCLAT for latch, and DOUT and DCDOUT for output, respectively. The device has three kinds of shift register latches such as the gray scale data, brightness control, and dot correction. The port and shift registers can be selected by RSEL0 and RSEL1. The selection of the shift registers will be done by RESL0 and RSEL1 as shown in Table 1. Note that the RSELn setting is done at DCLK low and DPOL high (DCLK is high when DPOL is low). When only port A is used, DCDIN, DCDOUT, DCCLK, and XDCLAT should be connected to GND.

Table 1. Shift Register Latch Selection

		SELECTED SHIFT REGISTER LATCH		
		PORT A	PORT B	
RSEL1	RSEL0	DIN, DCLK, XLATCH, DOUT	DCDIN, DCCLK, XDCLAT	DCDOUT
L	L	Gray scale data displayed	Dot correction	Dot correction
L	H	Brightness control	Dot correction	Dot correction
H	L	Dot correction (see Note 4)	Not connected	Dot correction
H	H	N/A (inhibit)	N/A (inhibit)	N/A (inhibit)

NOTE 4: Zero is output to DOUT7 through DOUT9.

shift register latch for gray scale data

The shift register latch for the gray scale data is configured with 16×10 bits. The gray scale data, configured with 10 bits, represents the time when constant current output is being turned on, and the data range is 0 to 1023 (00h to 3FFh). When the gray scale data is 0, the time is shortest, and the output is not turned on (light off). On the other hand, when the gray scale data is 1023, the time is longest, and it turns on during the time of the 1023 clocks from the gray scale clock. The configuration of the shift register and the latch for gray scale data is shown in Figure 3.

PRINCIPLES OF OPERATION

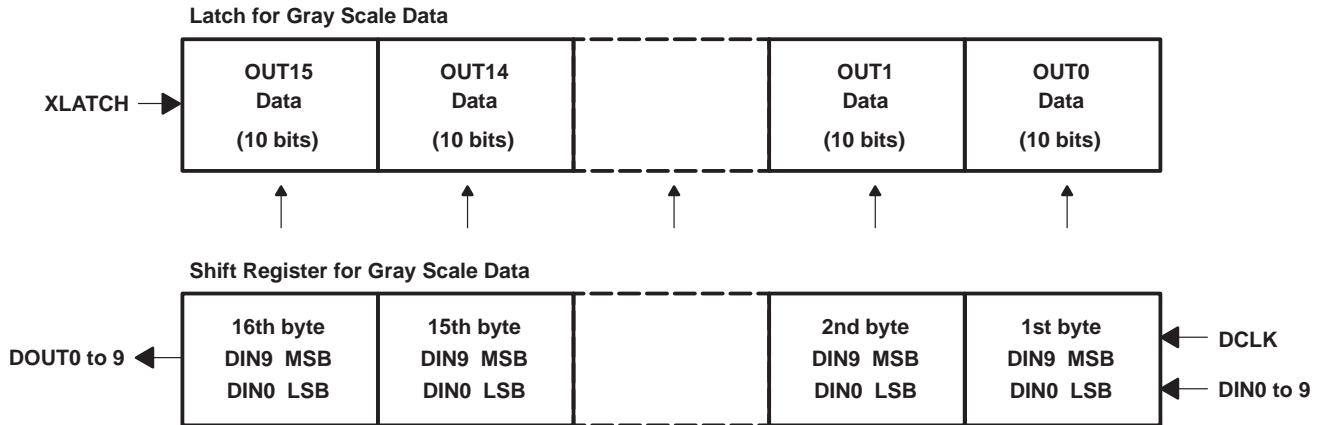
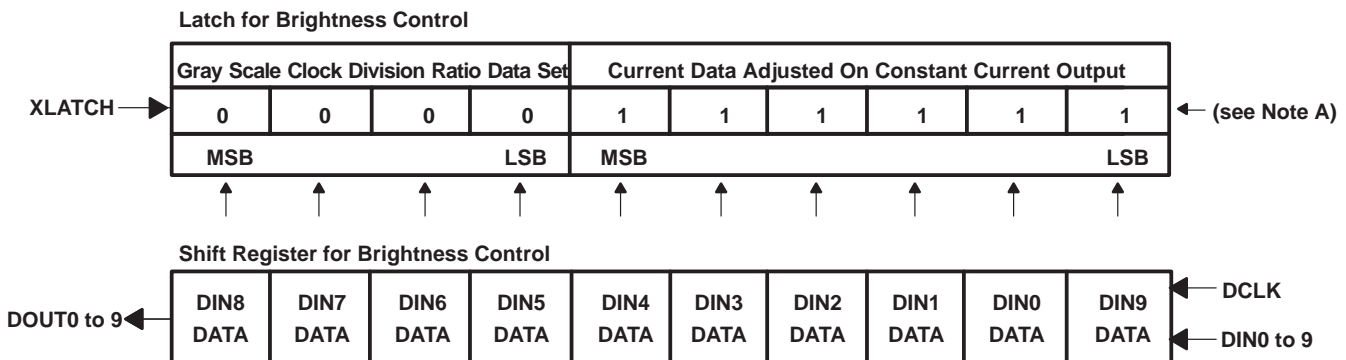

Figure 3. Relationship Between Shift Register and Latch for Gray Scale Data

shift register latch for brightness control

The shift register latch for brightness control is configured with 1×10 bits. Using the shift register latch for the brightness control, the division ratio of the gray scale clock can be set and the output current value on constant current output can be adjusted. When powered up, the latch data is indeterminate and the shift register is not initialized. When these functions are used, data should be written to the shift register latch prior to lighting-on (BLANK=L). Also, it is prohibited from rewriting the latch value for the brightness control when the constant current output is turned on. When these functions are not used, the latch value can be set to the default value setting of BCENA at low level (connect to GND). Also, DIN9 is assigned to the LSB of the reference current control to maintain compatibility with the TLC5901/02/03 family. The configuration of the shift register and the latch for brightness control is shown in Figure 4.



NOTE A: Indicates default value at BCENA low.

Figure 4. Relationship Between Shift Register and Latch for Brightness Control

shift register latch for dot correction

The shift register latch for dot correction is configured with 16×7 bits. Using the shift register latch for dot correction, the current value on the constant current output can be set individually. When powered up, the latch data is indeterminate and the shift register is not initialized. When these functions are used, data should be written to the shift register latch prior to lighting-on (BLANK=L). Also, rewriting the latch value for dot correction when the constant current output is turned on is inhibited. When these functions are not used, the latch value can be set to the default value setting of DCENA at low level (connect to GND). The configuration of the shift register and the latch for dot correction is shown in Figure 5.

PRINCIPLES OF OPERATION

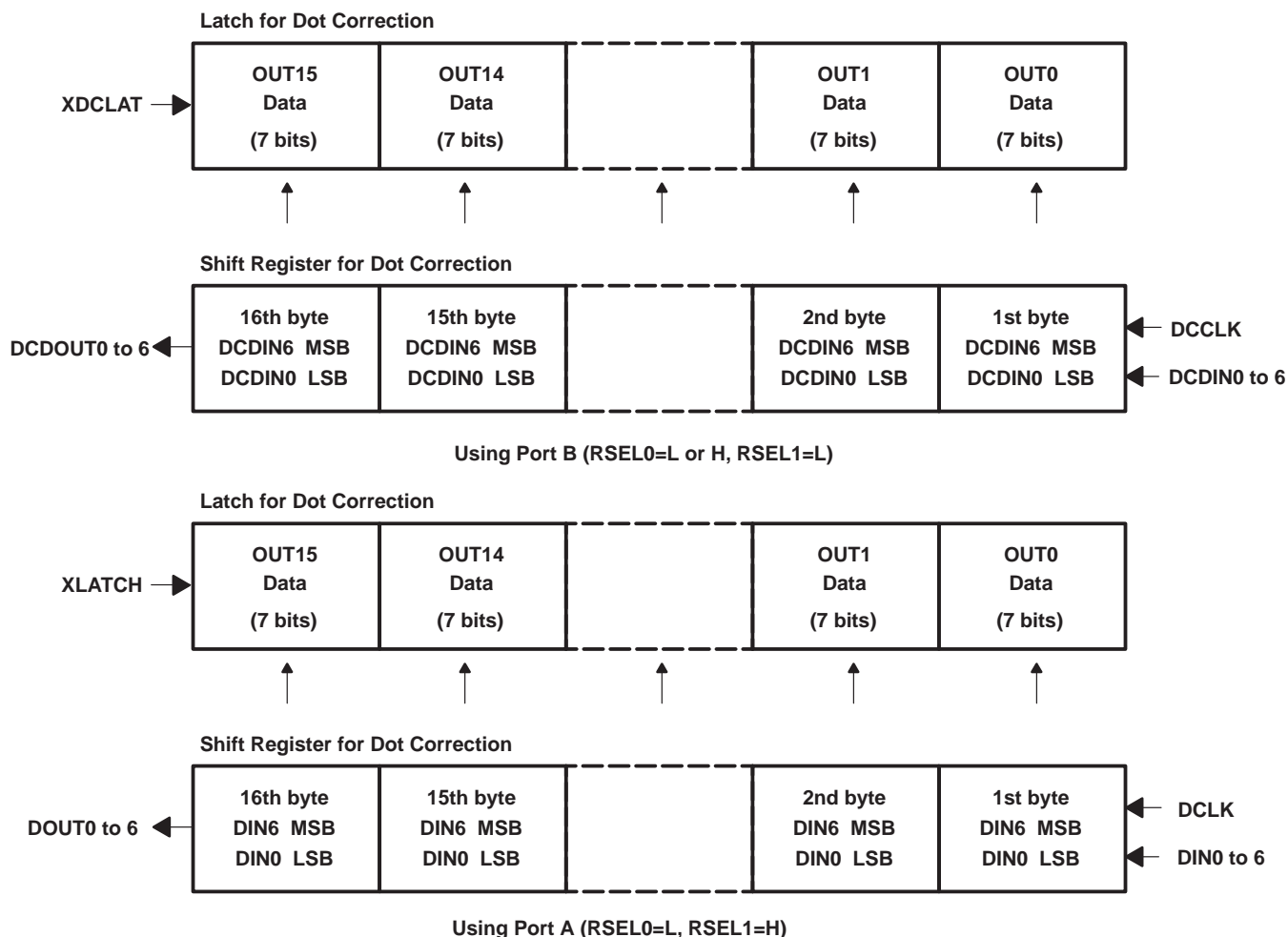

Figure 5. Relationship Between the Shift Register and the Latch for Dot Correction

write data to shift register latch

The shift register latch written is selected using the RSEL0 and RSEL1 terminal. At port A, the data is applied to the DIN data input terminal, clocked into the shift register and synchronized to the rising edge of DCLK after XENABLE is pulled low. At port B, the data is applied to the DCDIN data input terminal, clocked into the shift register, and synchronized to the rising edge of DCCLK. The shift register for the gray scale data is configured with 16×10 bits and the shift register for dot correction is configured with 16×7 bits resulting in sixteen times DCLK. The shift register for the brightness control is configured with 1×10 bits resulting in one times DCLK. At the number of DCLK input for each case, data can be written into the shift register. In this condition, when the XLATCH at port A or the XDCLAT at port B is pulled high, data in the shift register is clocked into the latch (data through). When the XLATCH at port A or XDCLAT at port B is pulled low, data is held (latch).

PRINCIPLES OF OPERATION

brightness control function

By writing data into the brightness control latch, current on all the constant current outputs can be adjusted to control the variation of brightness between ICs. The division ratio for the gray scale clock can be set to control the variation of brightness for the total panel system. Furthermore, by writing data into the dot correction latch, current on each constant current output can be adjusted.

output current adjustment on all constant current outputs – brightness adjustment between ICs

By using the lower 6 bits of the brightness control latch, output current can be adjusted in 64 steps as 1 step of 0.8% of the current ratio between 100% and 50.8% when the output current is set to 100% of an external resistor (note that the current value is lower if the constant current output is corrected using the dot correction function). By using this function, the brightness control between modules (ICs) can be adjusted sending the desired data externally even if ICs are mounted on a print-circuit board. When BCENA is pulled low, the output current is set to 100%.

Table 2. Relative Current Ratio For Total Constant Current Output

CURRENT RATIO %	20 (mA)	80 (mA)	CODE	V _{REF} (TYP)
50.8	10.2	40.6	MSB 000000 LSB	0.60
.
.
.
99.2	19.8	79.7	111110	1.19
100	20.0	80.0	111111†	1.20

† BCENA is low.

frequency division ratio setting for gray scale clock – panel brightness adjustment

By using the upper 4 bits of the brightness control latch, the gray scale clock can be divided into 1/1 to 1/16. If the gray scale clock is set to 16 times the speed of frequency (1024×16=16384) during horizontal scanning time, the brightness can be adjusted in 16 steps by selecting the frequency division ratio. By using this function, the total panel brightness can be adjusted at once, and applied to the brightness of day or night. When BCENA is pulled low, the gray scale clock is not divided. When BCENA is pulled high, the brightness can be adjusted as shown in Table 3.

Table 3. Relative Brightness Ratio For Total Constant Current Output

CODE	FREQUENCY DIVISION RATIO	RELATIVE BRIGHTNESS RATIO (%)
MSB 0000 LSB†	1/1	6.3
.	.	.
.	.	.
.	.	.
1110	1/15	93.8
1111	1/16	100

† BCENA is low.



PRINCIPLES OF OPERATION

output current adjustment on each constant current output – LED brightness adjustment

By using the dot correction latch, the output current on each constant current output can be adjusted in 128 steps as 1 step of 0.8% of the current ratio between 100% and 0% when the output current is set to 100% of an external resistor at 7Fh of the latched value and the lower 6 bits of the brightness control register. By using this function, the brightness deviation from the LED brightness variation can be minimized. When DCENA is pulled low, the output current is set to 100% without the dot correction.

Table 4. Relative Current Ratio By Constant Current Output

CODE	CURRENT RATIO %	I _{OL(C)} =40 (mA)
MSB 0000000 LSB	0.0	0.0
.	.	.
.	.	.
.	.	.
1111110	99.2	39.7
1111111†	100	40

† DCENA is low.

clock edge selection

The high speed clock signal is diminished due to the duty ratio change through the multiple stages of the IC or module as shown in Figure 6.

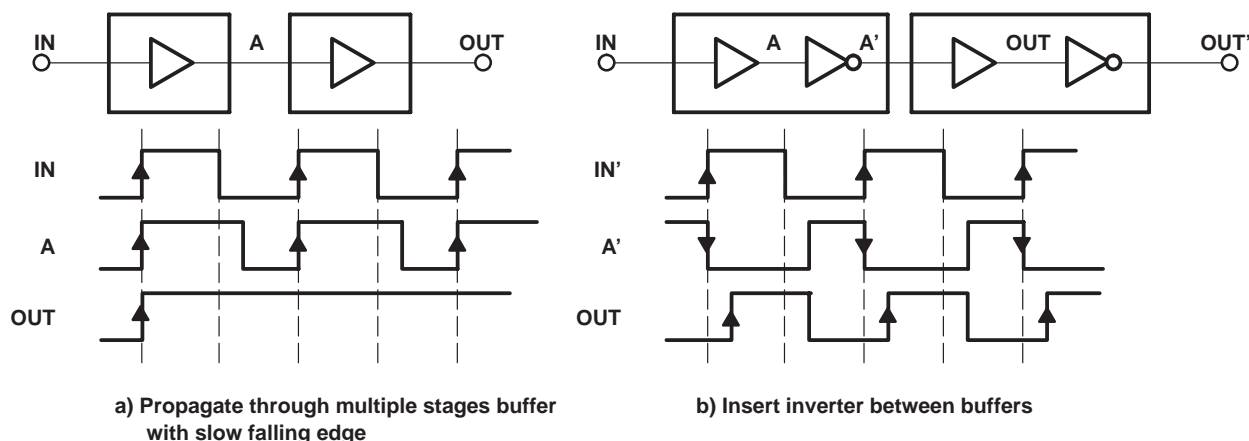

Figure 6. Clock Edge Selection

In Figure 6a, if the falling edge at the internal buffer is behind the rising edge, the clock will disappear if a multiple cascade connection is made. To resolve this problem, the duty ratio can be held unchanged using the connection as shown in Figure 6b if the valid clock edge can be selected (arrow in Figure 6). Note that the clock delay is not avoided even in this case.

The device incorporates the clock edge selection function for each DCLK and GSCLK. By using this function, the falling edge or rising edge for the valid edge can be selected depending on the status of DPOL and GSPOL, thus the degradation for the duty ratio can be reduced. The relationship between each signal is shown in Table 5.

PRINCIPLES OF OPERATION

Table 5. Valid Edge For DCLK and GSCLK

DPOL	DCLK valid edge	Operation at XENABLE = H
H	DCLK↑	Pull DCLK to low level
L	DCLK↓	Pull DCLK to high level

GSPOL	GSCLK valid edge	PLL operation
H	GSCLK↑	Synchronize to the high level of DCLK
L	GSCLK↓	Synchronize to the low level of DCLK

The device supplies the XPOUT and XGSOUT output terminals for the cascade operation which inverts GSPOL and GSCLK respectively. It also supplies the BOUT output terminal as a buffered BLANK to make timing easy with GSCLK and XGSOUT.

gray scale clock generation

When MAG<0:2> are all low, the clock input from the GSCLK terminal is used as the gray scale clock with no change, and except for this case the internal PLL generates the clock for the gray scale control clock. When using the PLL, the gray scale clock is generated by adjusting the clock to have the same number of pulses as the multiple ratio of the GSCLK reference period (when GSCLK and GSPOL are kept at the same level). The ratio in this case is determined depending on MAG0 through MAG2 as shown in Table 6.

When using the PLL, the internal PLLCLK is clocked out at the XGSOUT terminal. Therefore, the clock can be utilized for other devices on the same print-circuit board. Note that the number of ICs connected is limited depending on the frequency.

Table 6. PLL Multiple Ratio

MAG2	MAG1	MAG0	MULTIPLE RATIO	XGSOUT
L	L	L	1 (Signal to control GSCLK by GSPOL)	Inverted GSCLK
L	L	H	$2^8+6(=262)$	PLLCLK (Gray scale clock is internally generated)
L	H	L	$2^9+10(=522)$	
L	H	H	$2^{10}+18(=1042)$	
H	L	L	$2^{11}+34(=2082)$	
H	L	H	$2^{12}+66(=4162)$	
H	H	L	$2^{13}+130(=8322)$	
H	H	H	$2^{14}+258(=16642)$	

PRINCIPLES OF OPERATION

gray scale clock generation (continued)

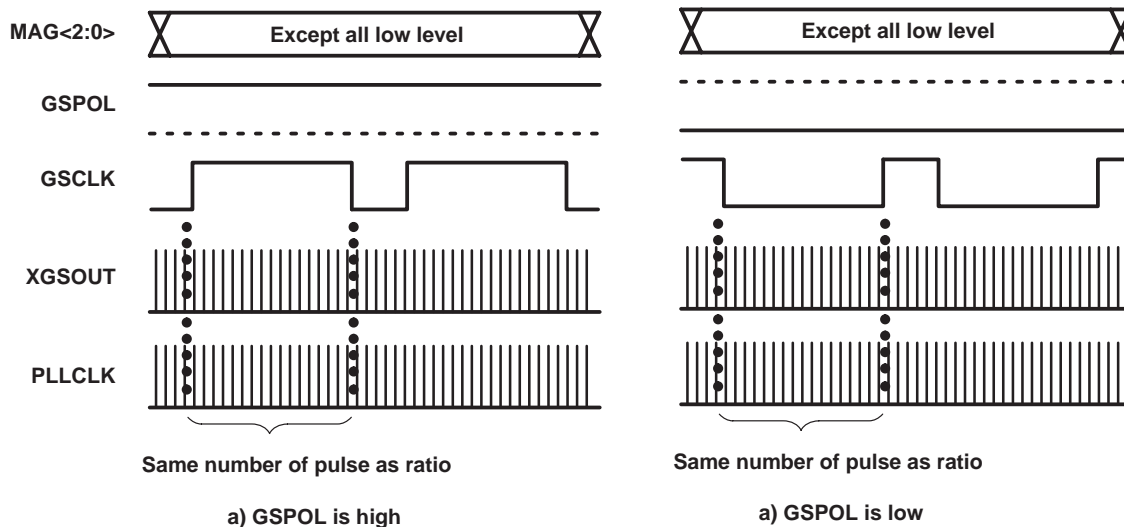

Figure 7. Gray Scale Clock Generation

The oscillation frequency bandwidth as referenced for the PLL can be set by an external resistor connected between RBIAS and GND. The relation between the external resistor and the oscillation frequency is shown in Table 7.

Table 7. PLL Oscillation Frequency

RBIAS	22 kΩ	30 kΩ	62 kΩ	120kΩ
FREQUENCY	13 to 16 MHz	8 to 14 MHz	4 to 9 MHz	3 to 5 MHz

Note that it takes 30 ms for the PLL to be stabilized. Furthermore, to make the PLL operation stabilized, a resistor and a capacitor connection is required between VCOIN, PDOUT and GND. The recommended values are shown in the Figure 8.



Figure 8. Resistor and Capacitor Connection

PRINCIPLES OF OPERATION

protection

This device incorporates WDT and TSD functions. If the WDT or TSD functions, the constant current output is stopped and XDOWN1 goes low. Therefore, by monitoring the XDOWN1 terminal, these failures can be detected immediately. Since the XDOWN1 output is configured as open collector, outputs of multiple ICs are brought together.

WDT (watchdog timer)

The constant current output is forced to turn off and XDOWN1 goes low when the fixed period elapsed after the signal applied to WDTRG has not been changed. Therefore, by connecting a scan signal (a signal to the control line displayed) to WDTRG, the stop of the scan signal can be detected and the constant current output is turned off preventing the LED from burning and damage caused by continuous LED turn on at the dynamic scanning operation. The detection time can be set using an external capacitor, C1. The typical value is approximately 10 ms without capacitor, 160 ms with a 1000 pF capacitor, and 1500 ms with a 0.01 μF capacitor. During static operation, the WDT function is disabled connecting the WDCAP to GND (high or low level should be applied to WDTRG). Note that normal operations will be resumed changing the WDTRG level when WDT functions.

$$\text{WDT operational time } T \text{ (ms)} \cong 10 + 0.15 \times C1 \text{ (pF)}$$

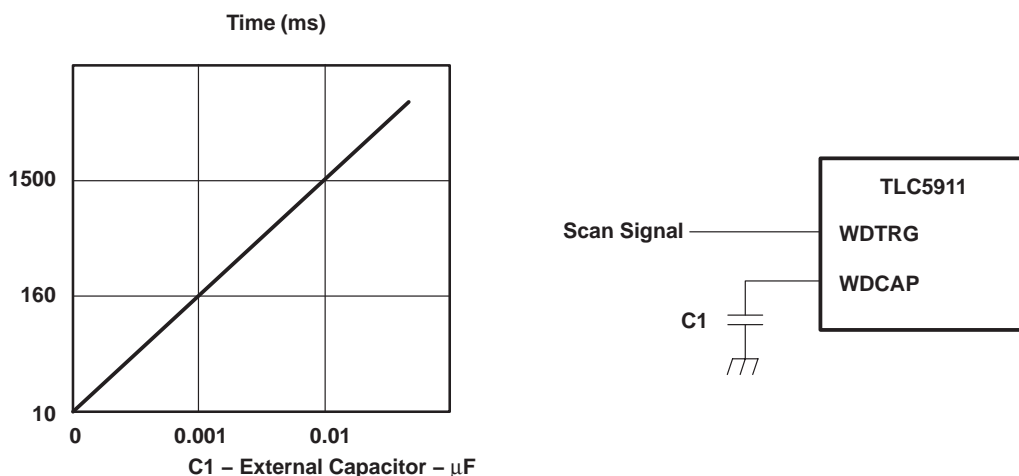

Figure 9. WDT Operational Time and Usage Example

TSD (thermal shutdown)

When the junction temperature exceeds the limit, TSD functions and turns the constant current output off, and XDOWN1 goes low. When TSD is used, TSENA is pulled high. When TSD is not used, TSENA is pulled low. To recover from the constant current output off-state to normal operations, the power supply should be turned off or TSENA should be pulled low once.

PRINCIPLES OF OPERATION

LOD function (LED open detection)

When LEDCHK is low, the LED disconnection detection function is disabled and XDOWN2 goes to a high-impedance state. When LEDCHK is high, the LED disconnection detection function is enabled, and XDOWN2 goes low if any LED is disconnected while monitoring the OUTn terminals to be turned on. This function is operational for sixteen OUTn terminals individually. To determine which constant current output is disconnected, the level of XDOWN2 is checked 16 times from OUT0 to OUT15 turning one constant current output on. The power supply voltage should be set so the constant current output applied is above 0.4 V when the LED is turned on normally. Also, since approximately 1000 ns is required from turning the constant current output on to XDOWN2 output, the gray scale data to be turned on during that period should be applied.

Table 8 is an example of XDOWN2 output status using four LEDs .

Table 8. XDOWN2 Output Example

LED NUMBER	1	2	3	4
LED STATUS	GOOD	NG	GOOD	NG
OUTn	ON	ON	ON	ON
DETECTION RESULT	GOOD	NG	GOOD	NG
XDOWN2	LOW (by case 2, 4)			
LED NUMBER	1	2	3	4
LED STATUS	GOOD	NG	GOOD	NG
OUTn	ON	ON	OFF	OFF
DETECTION RESULT	GOOD	NG	GOOD	GOOD
XDOWN2	LOW (by case 2)			
LED NUMBER	1	2	3	4
LED STATUS	GOOD	NG	GOOD	NG
OUTn	OFF	OFF	OFF	OFF
DETECTION RESULT	GOOD	GOOD	GOOD	GOOD
XDOWN2	HIGH-IMPEDANCE			

noise reduction

concurrent switching noise reduction

Concurrent switching noise has a potential to occur when multiple outputs turn on or off at the same time. To prevent this noise, the device has delay output terminals such as XGSOUT, BOUT for GSCLK (gray scale clock), and BLANK (blanking signal) respectively. By connecting these outputs to the GSCLK and BLANK terminals of next stage IC, it allows differences in the switching time between ICs. When GSCLK is output to GSOUT through the device, duty will be changed between input and output. The number of stages to be connected will be limited depending on the frequency.

delay between constant current output

The constant current output has a delay time of approximately 20 ns between outputs. It means approximately 300 ns delay time exists between OUT0 and OUT15. This time difference by delay is effective for the reduction of concurrent switching noise.

PRINCIPLES OF OPERATION

others

power supply

The following should be taken into consideration:

- VCCLOG, VCCANA and VCCLED should be supplied by a single power supply to minimize voltage differences between these terminals.
- The bypass capacitor should be located between the power supply and GND to eliminate the variation of power supply voltage.

GND

Although GNDLOG, GNDANA, and GNDLED are internally tied together, these terminals should be externally connected to reduce noise influence.

thermal pad

The thermal pad should be connected to GND to eliminate the noise influence, since it is connected to the bottom side of IC chip. Also, the desired thermal effect will be obtained by connecting this pad to the PCB pattern with better thermal conductivity.

power rating free-air temperature

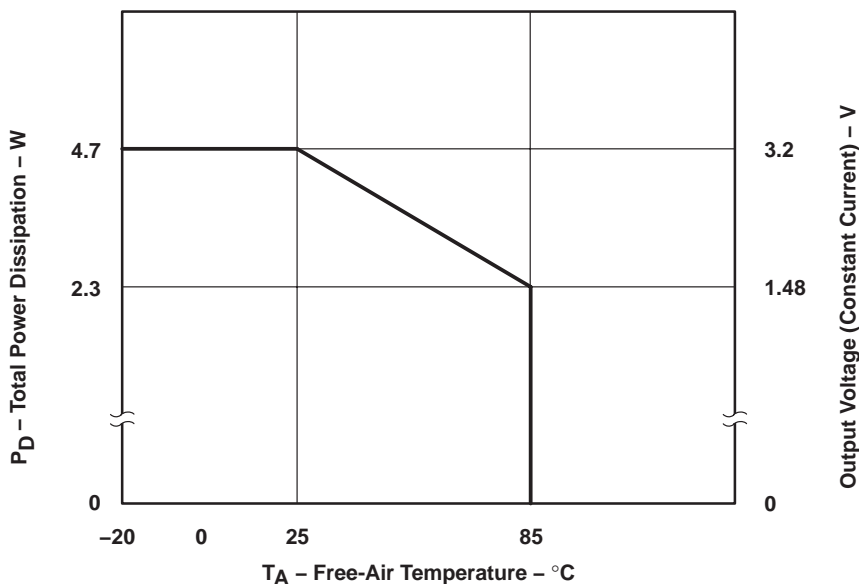

- NOTES: A. The IC is mounted on PCB.
 PCB size : 102 × 76 × 1.6 [mm³], four layers with the internal two layers being plane. The thermal pad is soldered to the PCB pattern of 10 × 10 [mm²]. For operation above 25°C free-air temperature, derate linearly at the rate of 38.2 mW/°C.
 VCC(LOG)=VCC(ANA)=VCC(LED)=5 V, IOL(C) = 80 mA, ICC is a typical value.
- B. The thermal impedance will be varied depending on the mounting conditions. Since the PZP package established a low thermal impedance by radiating heat from the thermal pad, the thermal pad should be soldered to the pattern with a low thermal impedance.
- C. The material for the PCB should be selected considering the thermal characteristics since the temperature will rise around the thermal pad.

Figure 10. Power Rating

PRINCIPLES OF OPERATION

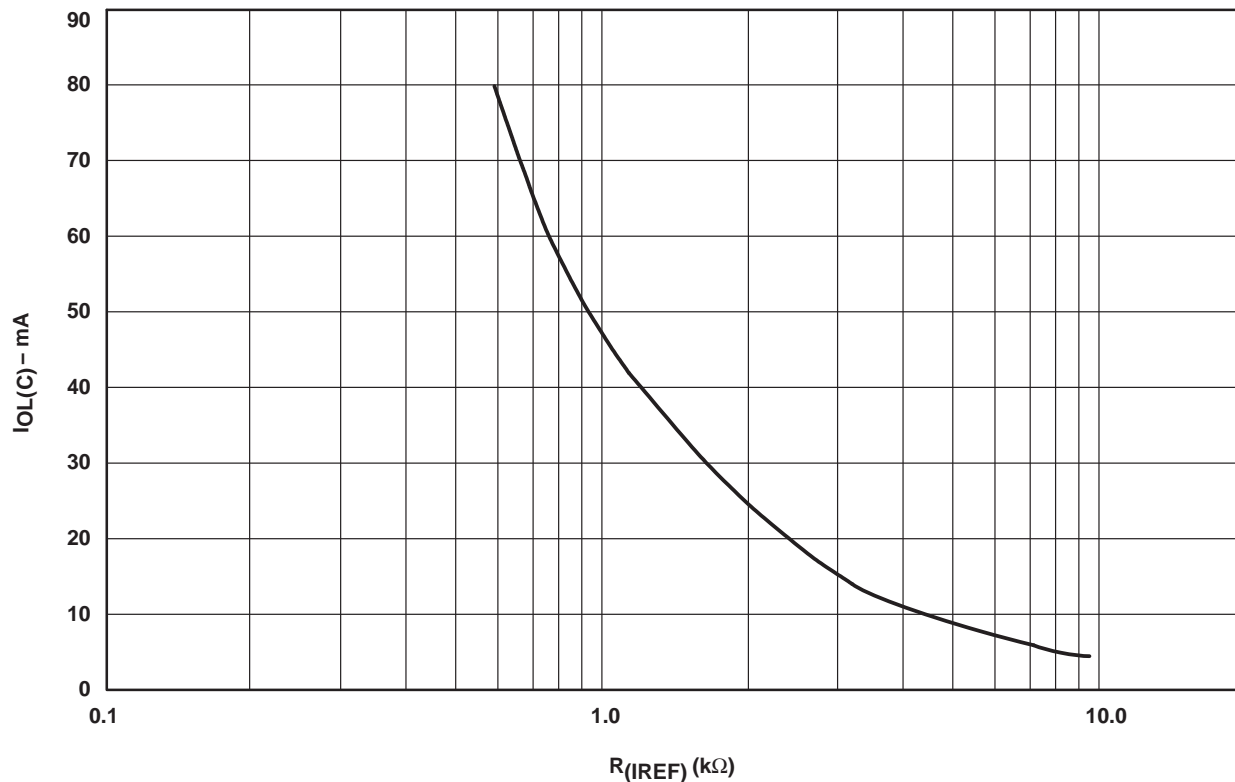

Conditions : $V_O = 1\text{ V}$, $V_{(IREF)} = 1.2\text{ V}$

$$I_{OL(C)} \text{ (mA)} \cong \frac{V_{(IREF)} \text{ (V)}}{R_{(IREF)} \text{ (k}\Omega)} \times 38$$

$$R_{(IREF)} \text{ (k}\Omega) \cong \frac{46}{I_{OL(C)} \text{ (mA)}}$$

NOTE: The brightness control and dot corrected value are set at 100%.
The resistor, $R_{(IREF)}$, should be located as close as possible to the IREF terminal to avoid noise influence.

Figure 11. Current on Constant Current Output vs External Resistor

TLC5911 LED DRIVER

SLLS402 – DECEMBER 1999

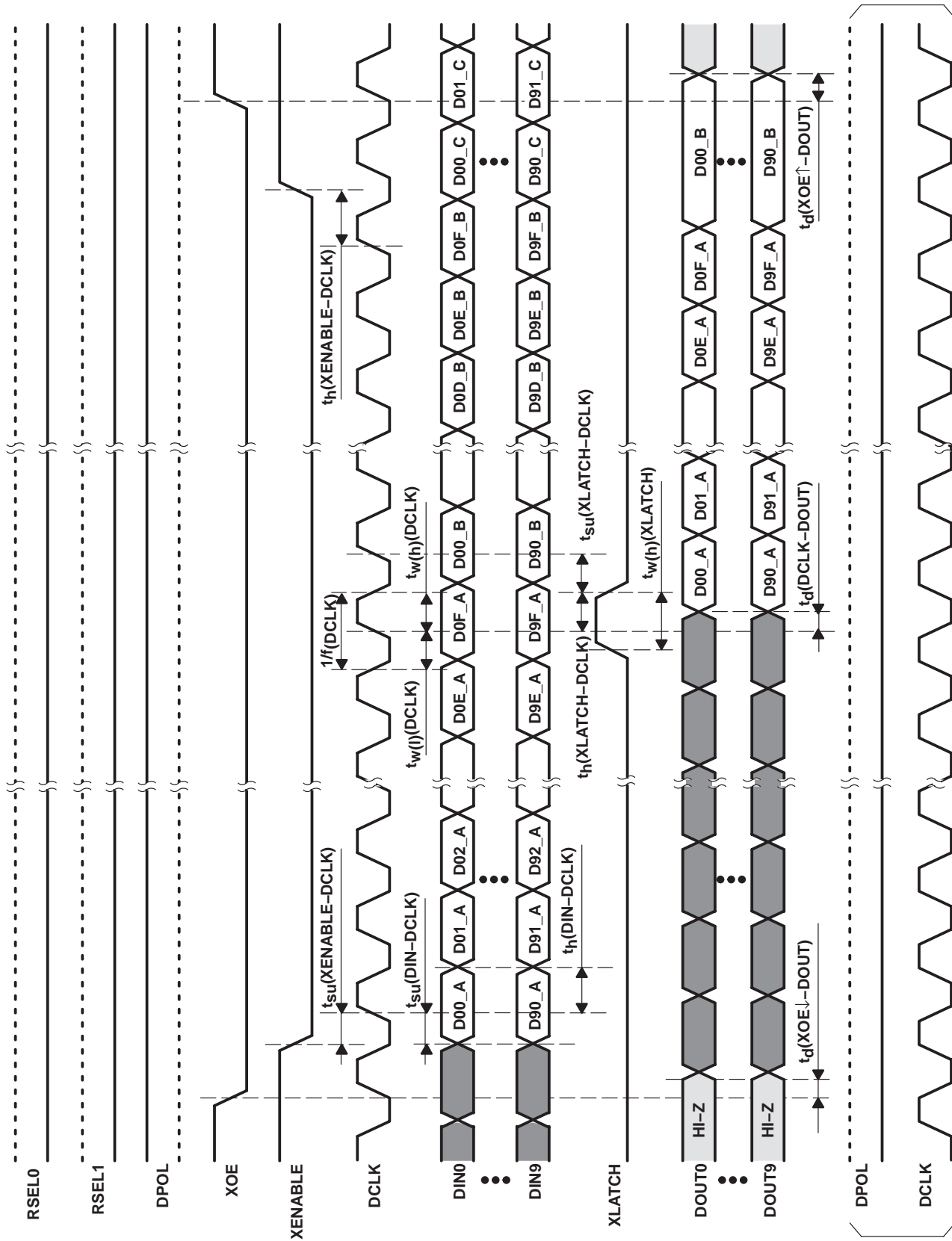
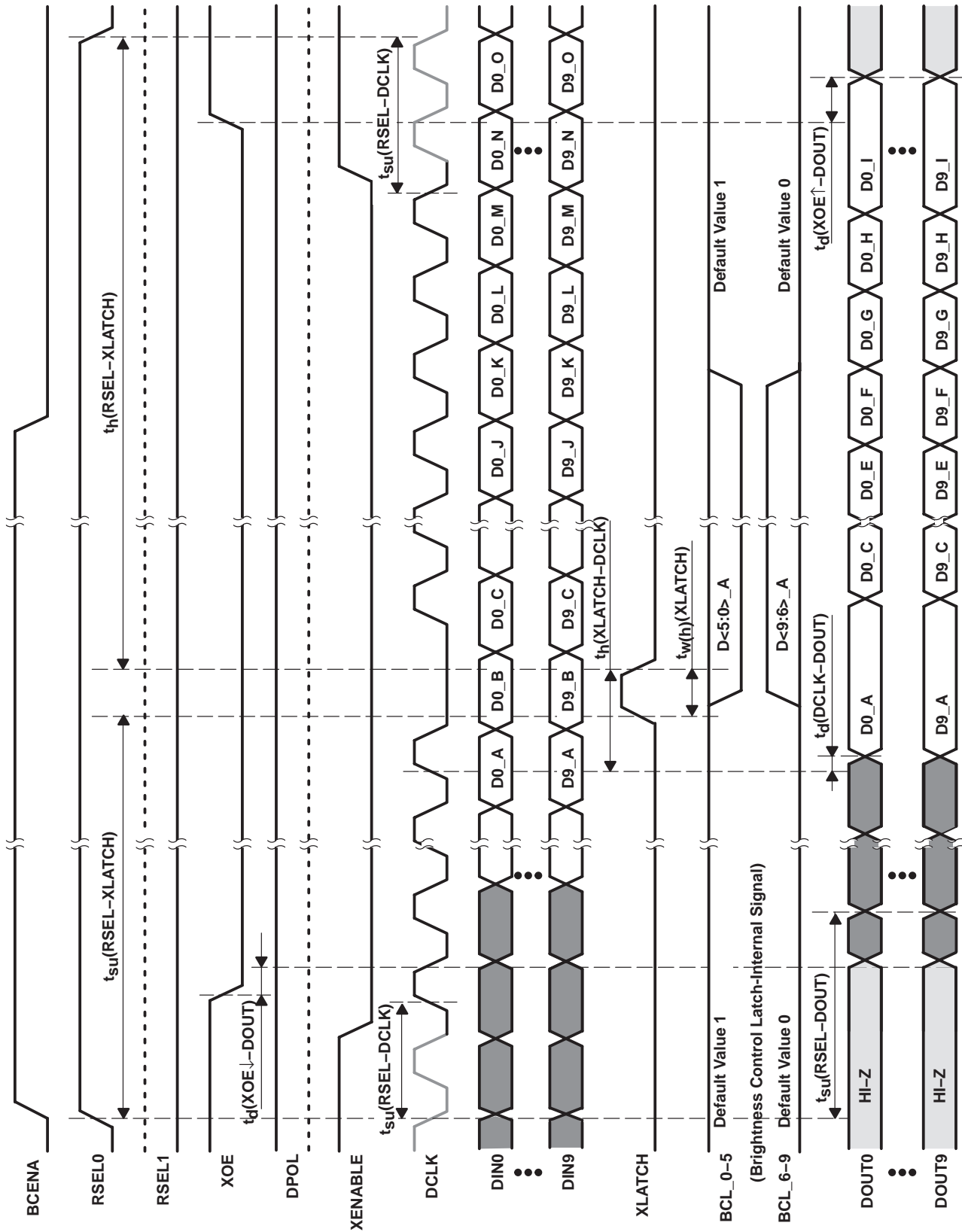

Figure 12. Timing Diagram (Shift Register for Gray Scale Data)
 DPOL and DCLK can be replaced with the combination of these signals enclosed by the parenthesis (Both are inverted each other).



DPOL and DCLK can be replaced with signals inverted each other same as shift register for gray scale data.

Figure 13. Timing Diagram (Shift Register for Brightness Control)

TLC5911 LED DRIVER

SLLS402 – DECEMBER 1999

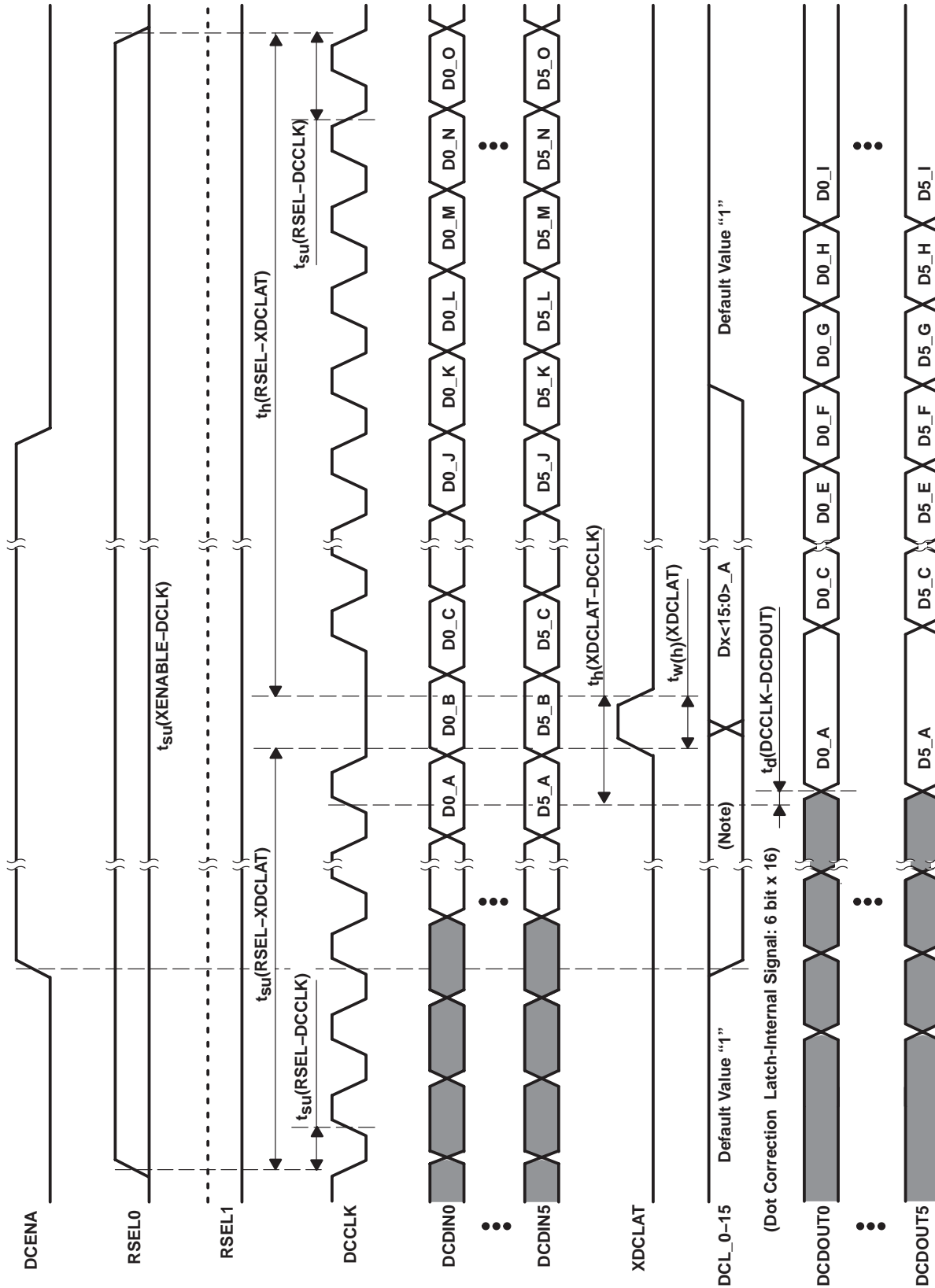

NOTE : Register value is immediately before DCLAT↓.

Figure 14. Timing Diagram (Shift Register for Dot Correction: Using Port B)

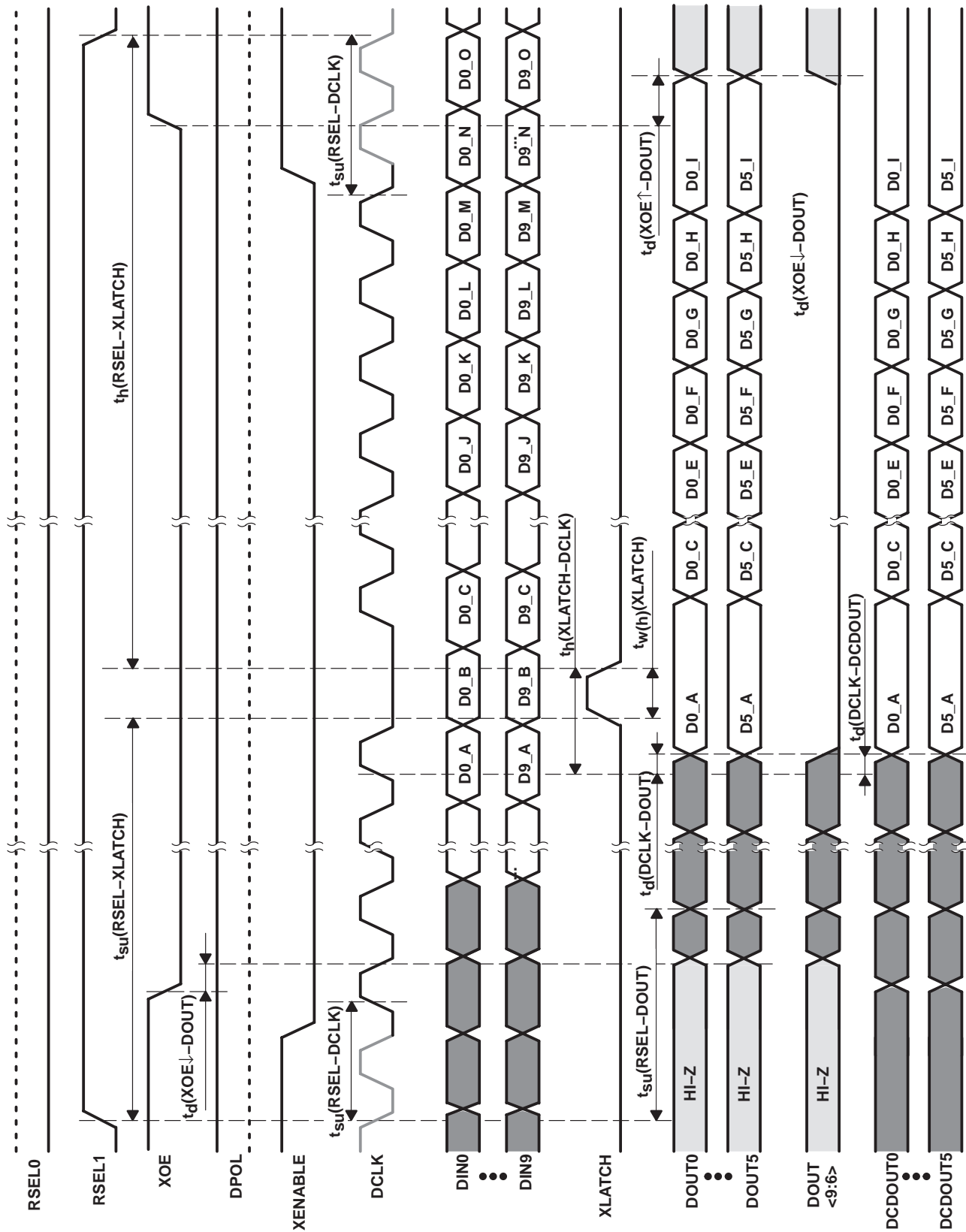

DPOL and DCLK can be replaced with signals inverted each other same as shift register for gray scale data.

Figure 15. Timing Diagram (Shift Register for Dot Correction: Using Port A)

TLC5911 LED DRIVER

SLLS402 – DECEMBER 1999

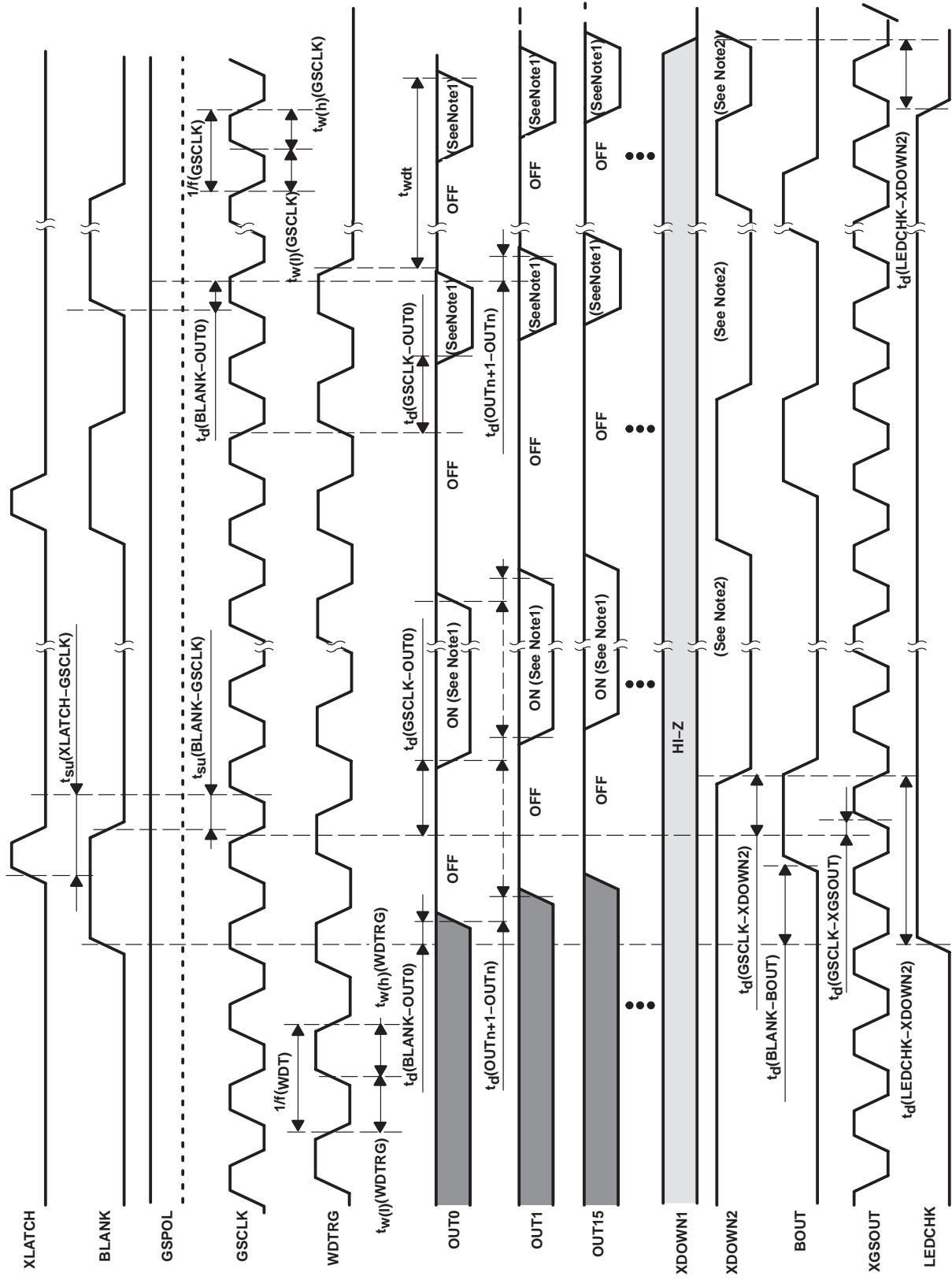

GSPOL, GSCLK and XGSOUT can be replaced with signals inverted each other.

NOTE 1: ON or OFF, or ON time is varied depend on the gray scale data and BLANK.

NOTE 2: When LED is disconnected.

Figure 16. Timing Diagram (Constant Current Output) – MAG0 to MAG2 Are All Zero

PACKAGING INFORMATION

Orderable Device	Status ⁽¹⁾	Package Type	Package Drawing	Pins	Package Qty	Eco Plan ⁽²⁾	Lead/Ball Finish	MSL Peak Temp ⁽³⁾
TLC5911PZP	ACTIVE	HTQFP	PZP	100	90	Green (RoHS & no Sb/Br)	CU NIPDAU	Level-3-260C-168 HR
TLC5911PZPG4	ACTIVE	HTQFP	PZP	100	90	Green (RoHS & no Sb/Br)	CU NIPDAU	Level-3-260C-168 HR

⁽¹⁾ The marketing status values are defined as follows:

ACTIVE: Product device recommended for new designs.

LIFEBUY: TI has announced that the device will be discontinued, and a lifetime-buy period is in effect.

NRND: Not recommended for new designs. Device is in production to support existing customers, but TI does not recommend using this part in a new design.

PREVIEW: Device has been announced but is not in production. Samples may or may not be available.

OBsolete: TI has discontinued the production of the device.

⁽²⁾ Eco Plan - The planned eco-friendly classification: Pb-Free (RoHS), Pb-Free (RoHS Exempt), or Green (RoHS & no Sb/Br) - please check <http://www.ti.com/productcontent> for the latest availability information and additional product content details.

TBD: The Pb-Free/Green conversion plan has not been defined.

Pb-Free (RoHS): TI's terms "Lead-Free" or "Pb-Free" mean semiconductor products that are compatible with the current RoHS requirements for all 6 substances, including the requirement that lead not exceed 0.1% by weight in homogeneous materials. Where designed to be soldered at high temperatures, TI Pb-Free products are suitable for use in specified lead-free processes.

Pb-Free (RoHS Exempt): This component has a RoHS exemption for either 1) lead-based flip-chip solder bumps used between the die and package, or 2) lead-based die adhesive used between the die and leadframe. The component is otherwise considered Pb-Free (RoHS compatible) as defined above.

Green (RoHS & no Sb/Br): TI defines "Green" to mean Pb-Free (RoHS compatible), and free of Bromine (Br) and Antimony (Sb) based flame retardants (Br or Sb do not exceed 0.1% by weight in homogeneous material)

⁽³⁾ MSL, Peak Temp. -- The Moisture Sensitivity Level rating according to the JEDEC industry standard classifications, and peak solder temperature.

Important Information and Disclaimer:The information provided on this page represents TI's knowledge and belief as of the date that it is provided. TI bases its knowledge and belief on information provided by third parties, and makes no representation or warranty as to the accuracy of such information. Efforts are underway to better integrate information from third parties. TI has taken and continues to take reasonable steps to provide representative and accurate information but may not have conducted destructive testing or chemical analysis on incoming materials and chemicals. TI and TI suppliers consider certain information to be proprietary, and thus CAS numbers and other limited information may not be available for release.

In no event shall TI's liability arising out of such information exceed the total purchase price of the TI part(s) at issue in this document sold by TI to Customer on an annual basis.

PZP (S-PQFP-G100)

PowerPAD™ PLASTIC QUAD FLATPACK

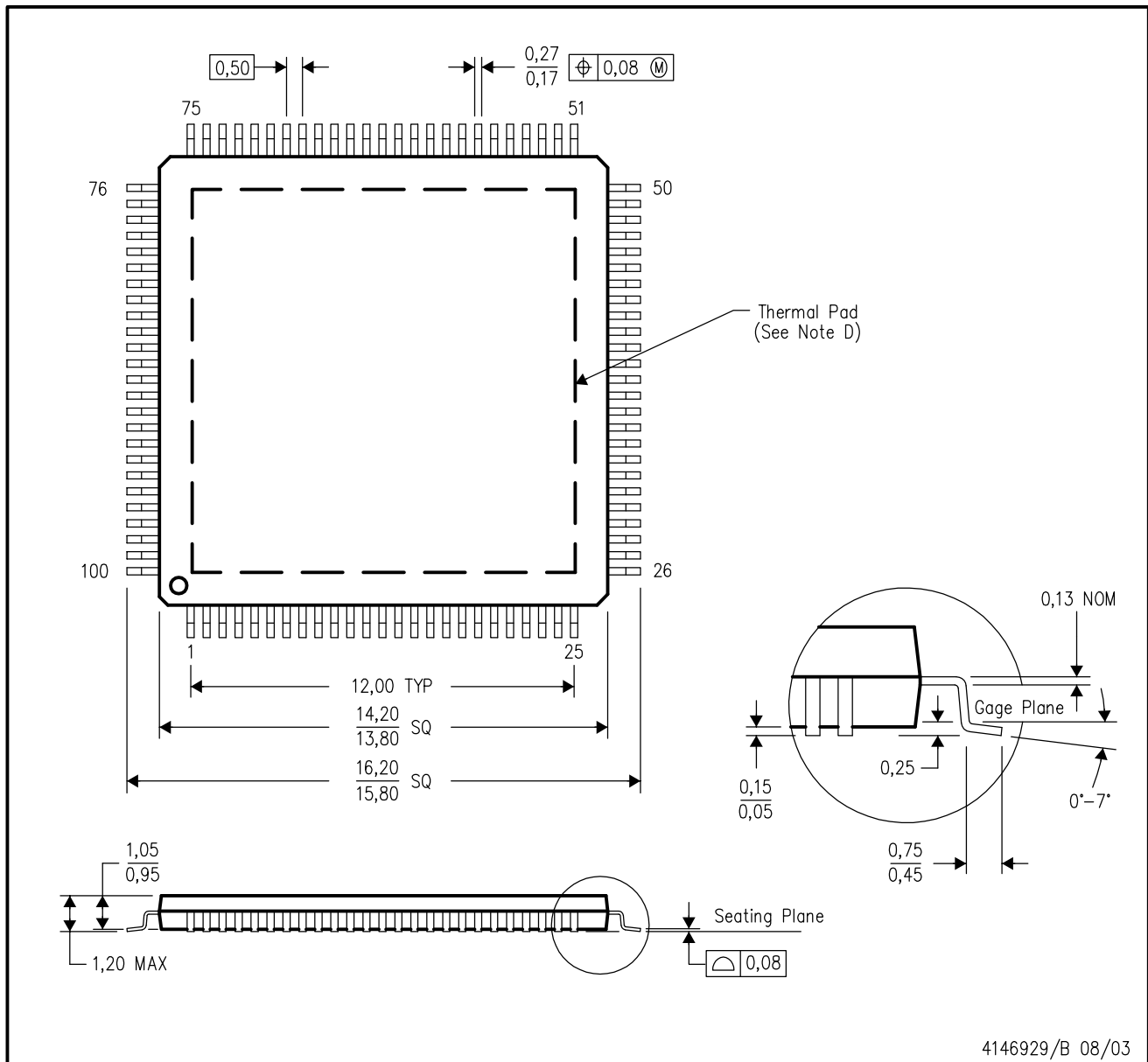

- NOTES:
- A. All linear dimensions are in millimeters.
 - B. This drawing is subject to change without notice.
 - C. Body dimensions do not include mold flash or protrusion
 - D. This package is designed to be molded to a thermal pad on the board. Refer to Technical Brief, PowerPad Thermally Enhanced Package, Texas Instruments Literature No. SLMA002 for information regarding recommended board layout. This document is available at www.ti.com <<http://www.ti.com>>.
 - E. Falls within JEDEC MS-026

PowerPAD is a trademark of Texas Instruments.

THERMAL INFORMATION

This PowerPAD™ package incorporates an exposed thermal pad that is designed to be attached directly to an external heatsink. The thermal pad must be soldered directly to the printed circuit board (PCB). After soldering, the PCB can be used as a heatsink. In addition, through the use of thermal vias, the thermal pad can be attached directly to the appropriate copper plane shown in the electrical schematic for the device, or alternatively, can be attached to a special heatsink structure designed into the PCB. This design optimizes the heat transfer from the integrated circuit (IC).

For additional information on the PowerPAD package and how to take advantage of its heat dissipating abilities, refer to Technical Brief, PowerPAD Thermally Enhanced Package, Texas Instruments Literature No. SLMA002 and Application Brief, PowerPAD Made Easy, Texas Instruments Literature No. SLMA004. Both documents are available at www.ti.com.

The exposed thermal pad dimensions for this package are shown in the following illustration.

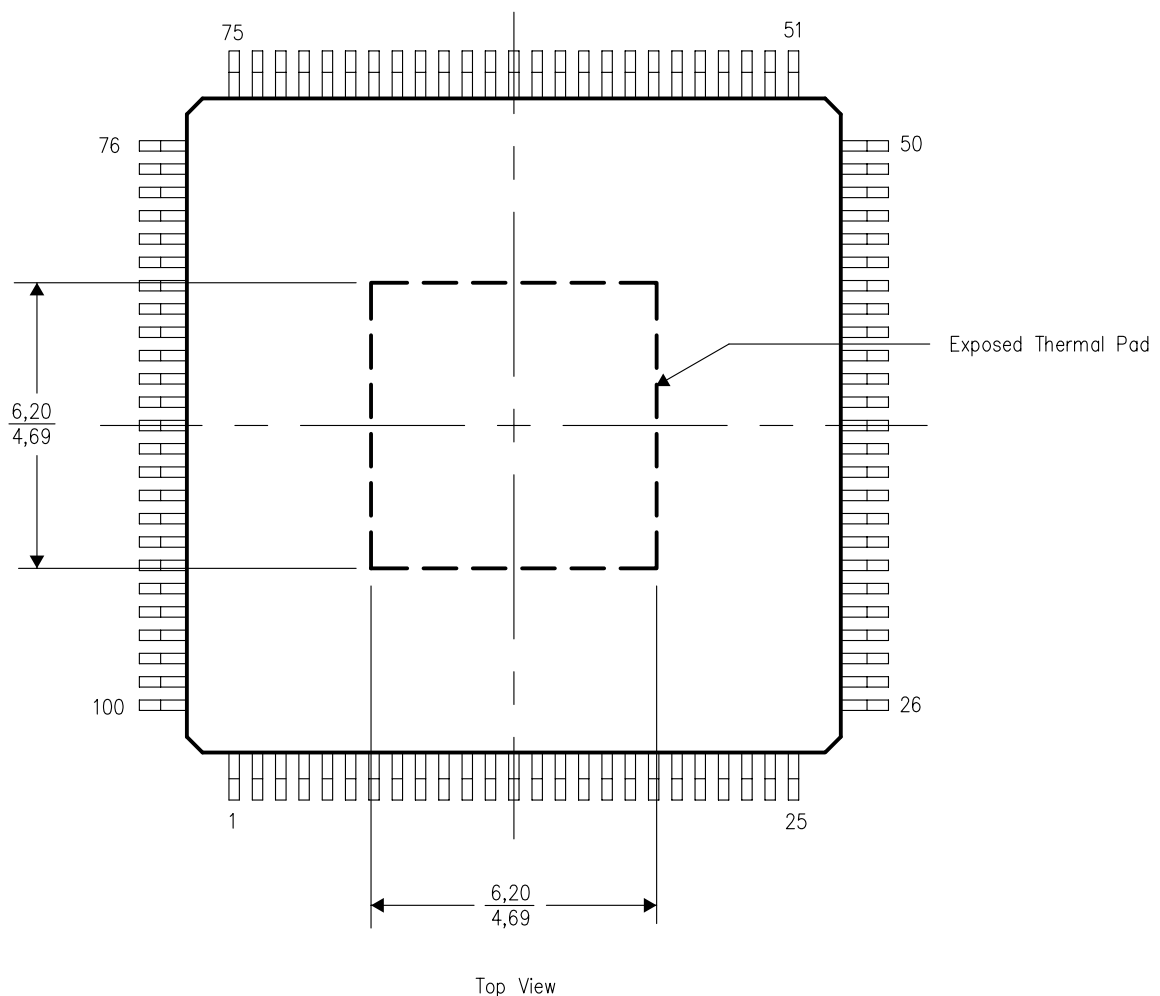

NOTE: All linear dimensions are in millimeters

Exposed Thermal Pad Dimensions

IMPORTANT NOTICE

Texas Instruments Incorporated and its subsidiaries (TI) reserve the right to make corrections, modifications, enhancements, improvements, and other changes to its products and services at any time and to discontinue any product or service without notice. Customers should obtain the latest relevant information before placing orders and should verify that such information is current and complete. All products are sold subject to TI's terms and conditions of sale supplied at the time of order acknowledgment.

TI warrants performance of its hardware products to the specifications applicable at the time of sale in accordance with TI's standard warranty. Testing and other quality control techniques are used to the extent TI deems necessary to support this warranty. Except where mandated by government requirements, testing of all parameters of each product is not necessarily performed.

TI assumes no liability for applications assistance or customer product design. Customers are responsible for their products and applications using TI components. To minimize the risks associated with customer products and applications, customers should provide adequate design and operating safeguards.

TI does not warrant or represent that any license, either express or implied, is granted under any TI patent right, copyright, mask work right, or other TI intellectual property right relating to any combination, machine, or process in which TI products or services are used. Information published by TI regarding third-party products or services does not constitute a license from TI to use such products or services or a warranty or endorsement thereof. Use of such information may require a license from a third party under the patents or other intellectual property of the third party, or a license from TI under the patents or other intellectual property of TI.

Reproduction of TI information in TI data books or data sheets is permissible only if reproduction is without alteration and is accompanied by all associated warranties, conditions, limitations, and notices. Reproduction of this information with alteration is an unfair and deceptive business practice. TI is not responsible or liable for such altered documentation. Information of third parties may be subject to additional restrictions.

Resale of TI products or services with statements different from or beyond the parameters stated by TI for that product or service voids all express and any implied warranties for the associated TI product or service and is an unfair and deceptive business practice. TI is not responsible or liable for any such statements.

TI products are not authorized for use in safety-critical applications (such as life support) where a failure of the TI product would reasonably be expected to cause severe personal injury or death, unless officers of the parties have executed an agreement specifically governing such use. Buyers represent that they have all necessary expertise in the safety and regulatory ramifications of their applications, and acknowledge and agree that they are solely responsible for all legal, regulatory and safety-related requirements concerning their products and any use of TI products in such safety-critical applications, notwithstanding any applications-related information or support that may be provided by TI. Further, Buyers must fully indemnify TI and its representatives against any damages arising out of the use of TI products in such safety-critical applications.

TI products are neither designed nor intended for use in military/aerospace applications or environments unless the TI products are specifically designated by TI as military-grade or "enhanced plastic." Only products designated by TI as military-grade meet military specifications. Buyers acknowledge and agree that any such use of TI products which TI has not designated as military-grade is solely at the Buyer's risk, and that they are solely responsible for compliance with all legal and regulatory requirements in connection with such use.

TI products are neither designed nor intended for use in automotive applications or environments unless the specific TI products are designated by TI as compliant with ISO/TS 16949 requirements. Buyers acknowledge and agree that, if they use any non-designated products in automotive applications, TI will not be responsible for any failure to meet such requirements.

Following are URLs where you can obtain information on other Texas Instruments products and application solutions:

Products		Applications	
Amplifiers	amplifier.ti.com	Audio	www.ti.com/audio
Data Converters	dataconverter.ti.com	Automotive	www.ti.com/automotive
DSP	dsp.ti.com	Broadband	www.ti.com/broadband
Interface	interface.ti.com	Digital Control	www.ti.com/digitalcontrol
Logic	logic.ti.com	Military	www.ti.com/military
Power Mgmt	power.ti.com	Optical Networking	www.ti.com/opticalnetwork
Microcontrollers	microcontroller.ti.com	Security	www.ti.com/security
RFID	www.ti-rfid.com	Telephony	www.ti.com/telephony
Low Power Wireless	www.ti.com/lpw	Video & Imaging	www.ti.com/video
		Wireless	www.ti.com/wireless

Mailing Address: Texas Instruments, Post Office Box 655303, Dallas, Texas 75265
Copyright © 2007, Texas Instruments Incorporated