

LMH6715QML

LMH6715QML Dual Wideband Video Op Amp



Literature Number: SNOSAQ3A

LMH6715QML

Dual Wideband Video Op Amp

General Description

The LMH6715 combines National's VIP10™ high speed complementary bipolar process with National's current feedback topology to produce a very high speed dual op amp. The LMH6715 provides 400MHz small signal bandwidth at a gain of +2V/V and 1300V/μs slew rate while consuming only 5.8mA per amplifier from ±5V supplies.

The LMH6715 offers exceptional video performance with its 0.02% and 0.02° differential gain and phase errors for NTSC and PAL video signals while driving up to four back terminated 75Ω loads. The LMH6715 also offers a flat gain response of 0.1dB to 100MHz and very low channel-to-channel crosstalk of -70dB at 10MHz. Additionally, each amplifier can deliver 70mA of output current. This level of performance makes the LMH6715 an ideal dual op amp for high density, broadcast quality video systems.

The LMH6715's two very well matched amplifiers support a number of applications such as differential line drivers and receivers. In addition, the LMH6715 is well suited for Sallen Key active filters in applications such as anti-aliasing filters for high speed A/D converters. Its low power requirement, low noise and distortion allow the LMH6715 to serve portable RF applications such as IQ channels.

Features

- Available with radiation guaranteed 300 krad(Si)
T_A = 25°C, R_L = 100Ω, typical values unless specified.
- Very low diff. gain, phase: 0.02%, 0.02°
- Wide bandwidth: 480MHz (A_V = +1V/V); 400MHz (A_V = +2V/V)
- 0.1dB gain flatness to 100MHz
- Low power: 5.8mA/channel
- -70dB channel-to-channel crosstalk (10MHz)
- Fast slew rate: 1300V/μs
- Unity gain stable
- Improved replacement for CLC412

Applications

- HDTV, NTSC & PAL video systems
- Video switching and distribution
- IQ amplifiers
- Wideband active filters
- Cable drivers
- DC coupled single-to-differential conversions

Ordering Information

NS Part Number	SMD Part Number	NS Package Number	Package Description
LMH6715J-QML	5962-0254701MPA	J08A	8LD CERDIP
LMH6715JFQMLV	5962F0254701VPA 300 krad(Si)	J08A	8LD CERDIP

Connection Diagram

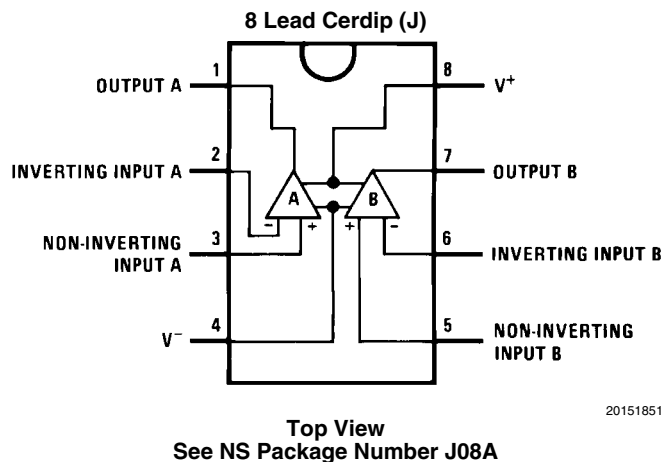

VIP10™ is a trademark of National Semiconductor Corporation.

Absolute Maximum Ratings *(Note 1)*

Supply Voltage (V_{CC})	$\pm 6.75V$
Common Mode Input Voltage (V_{CM})	$V^+ - V^-$
Differential Input Voltage	$V^+ - V^-$
Power Dissipation (P_D) <i>(Note 2)</i>	1.0W
Lead Temperature (Soldering, 10 seconds)	+300°C
Junction Temperature (T_J)	+175°C
Storage Temperature Range	$-65^\circ C \leq T_A \leq +150^\circ C$
Thermal Resistance	
θ_{JA}	
Cerdip (Still Air)	140°C/W
Cerdip (500LF/Min Air Flow)	80°C/W
θ_{JC}	
Cerdip	32°C/W
Package Weight (typical)	
CERDIP	1130mg
ESD Tolerance <i>(Note 3)</i>	2000V

Recommended Operating Ratings

Supply Voltage (V_{CC})	$\pm 5V_{DC}$ to $\pm 6V_{DC}$
Ambient Operating Temperature Range (T_A)	$-55^\circ C \leq T_A \leq +125^\circ C$

Quality Conformance Inspection

MIL-STD-883, Method 5005 - Group A

Subgroup	Description	Temp (°C)
1	Static tests at	+25
2	Static tests at	+125
3	Static tests at	-55
4	Dynamic tests at	+25
5	Dynamic tests at	+125
6	Dynamic tests at	-55
7	Functional tests at	+25
8A	Functional tests at	+125
8B	Functional tests at	-55
9	Switching tests at	+25
10	Switching tests at	+125
11	Switching tests at	-55

LMH6715 Electrical Characteristics

DC Parameter Static and DC Tests

The following conditions apply, unless otherwise specified.

$$R_L = 100\Omega, V_{CC} = \pm 5V_{DC}, A_V = +2, R_F = 634\Omega, -55^\circ\text{C} \leq T_A \leq +125^\circ\text{C}$$

Symbol	Parameter	Conditions	Notes	Min	Max	Unit	Sub-groups
I_{BN}	Input Bias Current, Noninverting		(Note 6)	-12	12	μA	1
				-12	+12	μA	2
				-20	+20	μA	3
I_{BI}	Input Bias Current, Inverting		(Note 6)	-21	+21	μA	1
				-25	+25	μA	2
				-35	+35	μA	3
V_{IO}	Input offset voltage		(Note 6)	-6	6	mV	1
				-12	12	mV	2
				-10	10	mV	3
I_{CC}	Supply Current	$R_L = \infty$	(Note 6)		14.0	mA	1
					14.0	mA	2
					16.0	mA	3
PSRR	Power Supply Rejection Ratio	$+V_S = +4.5\text{V to } +5.0\text{V},$ $-V_S = -4.5\text{V to } -5.0\text{V}$		46		dB	1
				44		dB	2, 3

AC Parameter Frequency Domain Response

The following conditions apply, unless otherwise specified.

$$R_L = 100\Omega, V_{CC} = \pm 5V_{DC}, A_V = +2, R_F = 634\Omega, -55^\circ\text{C} \leq T_A \leq +125^\circ\text{C}$$

Symbol	Parameter	Conditions	Notes	Min	Max	Unit	Sub-groups
SS_{BW}	Small signal bandwidth	-3dB BW, $V_{OUT} < 0.5 V_{PP}$	(Note 5)	175		MHz	4
GFP	Gain flatness peaking high	0.1MHz to 30 MHz, $V_{OUT} \leq 0.5V_{PP}$	(Note 5)		0.1	dB	4
GFR	Gain flatness rolloff	0.1MHz to 30 MHz, $V_{OUT} \leq 0.5V_{PP}$	(Note 5)		0.3	dB	4

AC Parameter Distortion and Noise Response

The following conditions apply, unless otherwise specified.

$$R_L = 100\Omega, V_{CC} = \pm 5V_{DC}, A_V = +2, R_F = 634\Omega, -55^\circ\text{C} \leq T_A \leq +125^\circ\text{C}$$

Symbol	Parameter	Conditions	Notes	Min	Max	Unit	Sub-groups
HD_2	Second harmonic distortion	$2V_{PP}$ at 20 MHz	(Note 5)		-42	dBc	4
HD_3	Third harmonic distortion	$2V_{PP}$ at 20 MHz	(Note 5)		-46	dBc	4

DC Parameter Drift Values

The following conditions apply, unless otherwise specified.

Deltas not required on B Level product. Deltas required for S Level product at Group B5 only, or as specified on the Internal Processing Instructions (IPI).

Symbol	Parameter	Conditions	Notes	Min	Max	Unit	Sub-groups
I_{BN}	Input Bias Current, Noninverting		(Note 4)	-1.2	+1.2	μA	1
I_{BI}	Input Bias Current, Inverting		(Note 4)	-2.0	+2.0	μA	1
V_{IO}	Input Offset Voltage		(Note 4)	-1.0	+1.0	mV	1
I_{CC}	Supply Current	$R_L = \infty$	(Note 4)	-1.0	+1.0	mA	1

Note 1: Absolute Maximum Ratings indicate limits beyond which damage to the device may occur. Operating Ratings indicate conditions for which the device is functional, but do not guarantee specific performance limits. For guaranteed specifications and test conditions, see the Electrical Characteristics. The guaranteed specifications apply only for the test conditions listed. Some performance characteristics may degrade when the device is not operated under the listed test conditions.

Note 2: The maximum power dissipation must be derated at elevated temperatures and is dictated by T_{Jmax} (maximum junction temperature), θ_{JA} (package junction to ambient thermal resistance), and T_A (ambient temperature). The maximum allowable power dissipation at any temperature is $P_{Dmax} = (T_{Jmax} - T_A) / \theta_{JA}$ or the number given in the Absolute Maximum Ratings, whichever is lower.

Note 3: Human body model, 1.5k Ω in series with 100 pF.

Note 4: If not tested, shall be guaranteed to the limits specified in table 1 herein.

Note 5: Group A testing only.

Note 6: Pre and post irradiation limits are identical to those listed under electrical characteristics. These parts may be dose rate sensitive in a space environment and demonstrate enhanced low dose rate effect. Radiation end point limits for the noted parameters are guaranteed only for the conditions as specified in MIL-STD-883, Method 1019.

Differential Gain & Phase with Multiple Video Loads

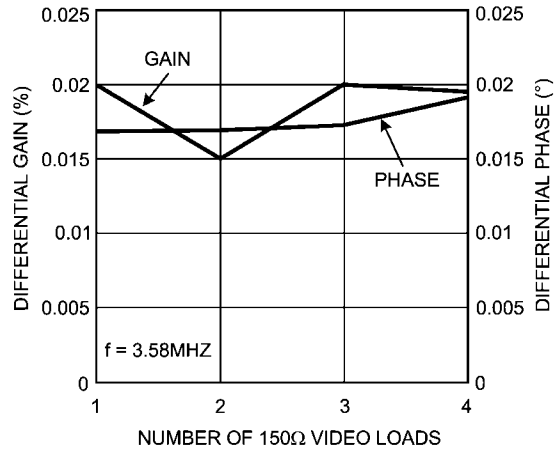

20151808

Frequency Response vs. V_{OUT}

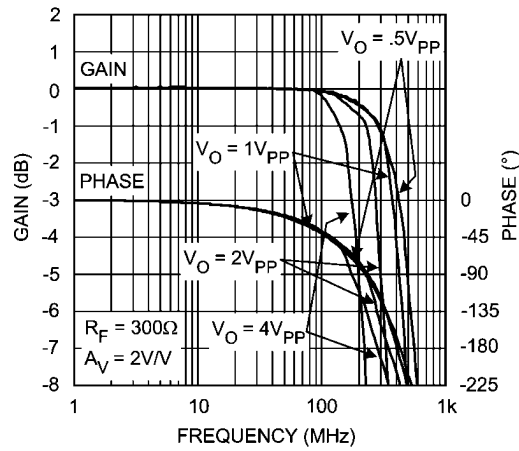

20151816

Typical Performance Characteristics

($T_A = 25^\circ\text{C}$, $V_{CC} = \pm 5\text{V}$, $A_V = \pm 2\text{V/V}$, $R_F = 500\Omega$, $R_L = 100\Omega$, unless otherwise specified).

Non-Inverting Frequency Response

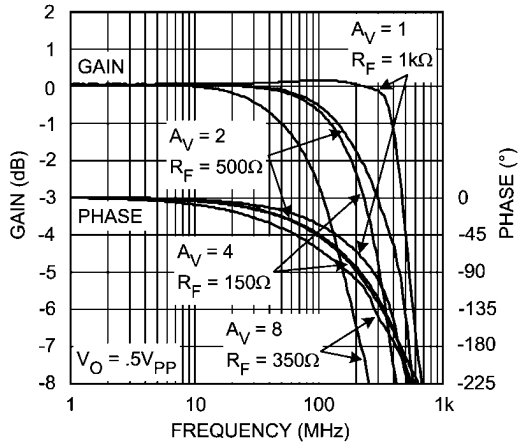

20151813

Inverting Frequency Response

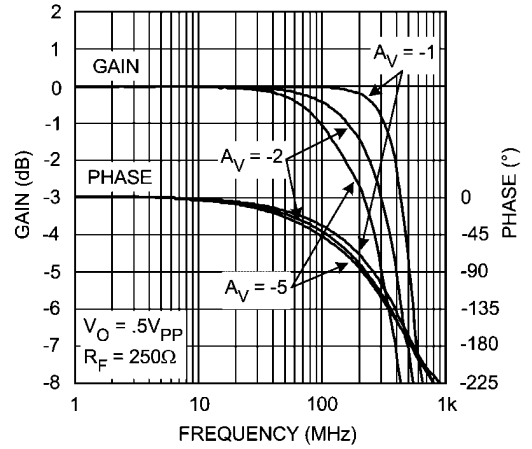

20151812

Non-Inverting Frequency Response vs. V_{OUT}

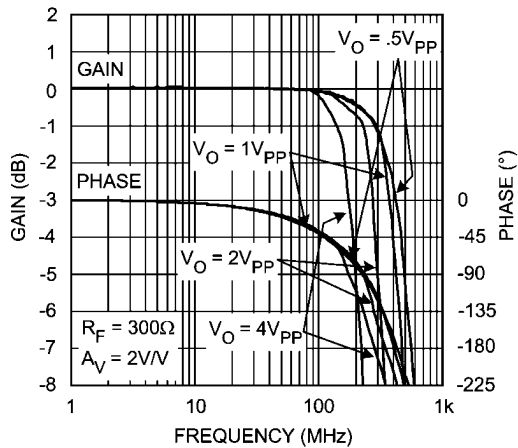

20151816

Small Signal Channel Matching

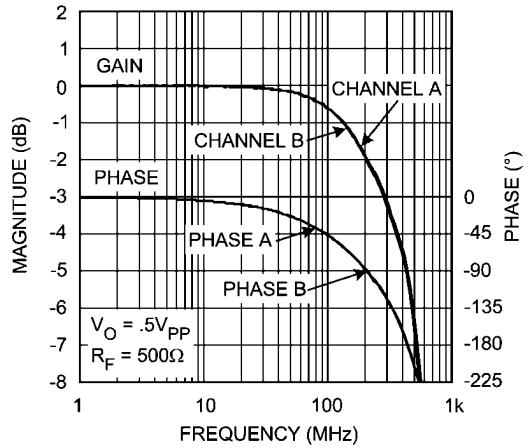

20151801

Frequency Response vs. Load Resistance

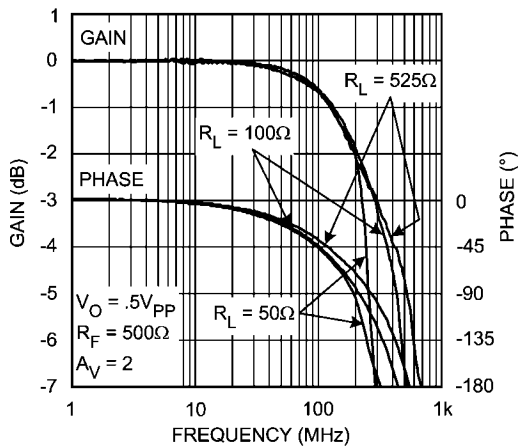

20151815

Non-Inverting Frequency Response vs. R_F

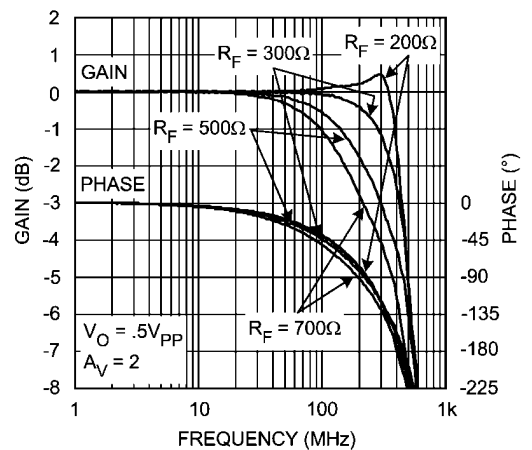

20151814

Small Signal Pulse Response

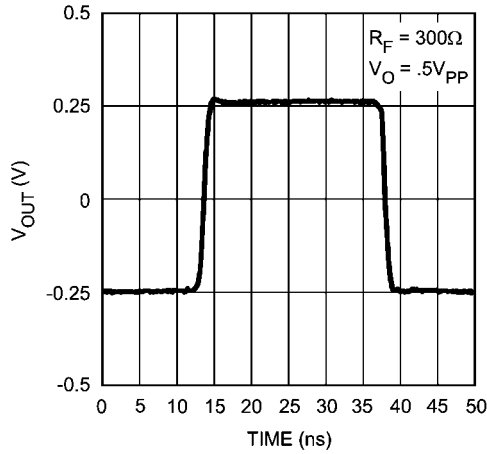

20151818

Large Signal Pulse Response

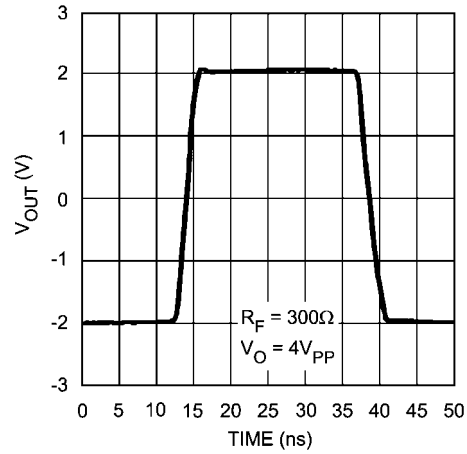

20151819

Input-Referred Crosstalk

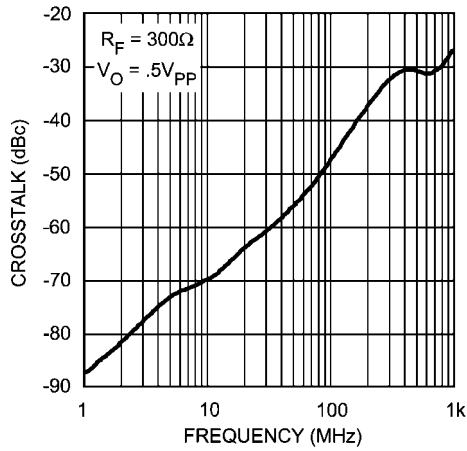

20151807

Settling Time vs. Accuracy

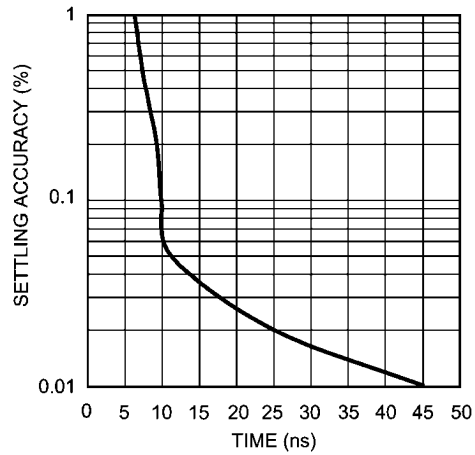

20151824

-3dB Bandwidth vs. V_{OUT}

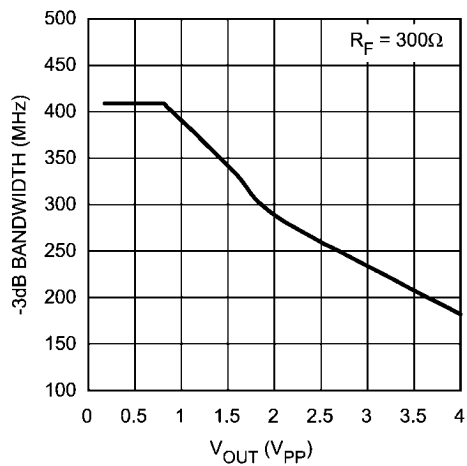

20151825

DC Errors vs. Temperature

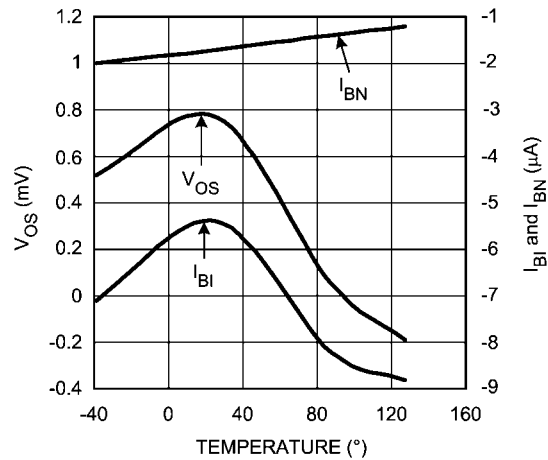

20151826

Open Loop Transimpedance, Z(s)

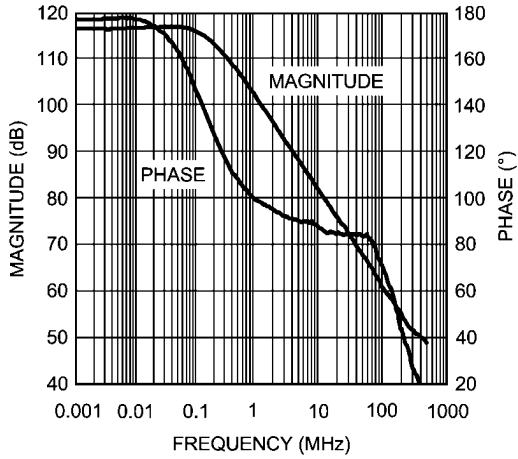

20151820

Equivalent Input Noise vs. Frequency

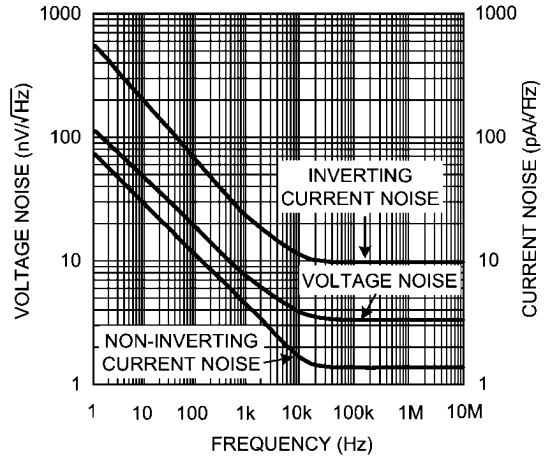

20151823

Differential Gain & Phase vs. Load

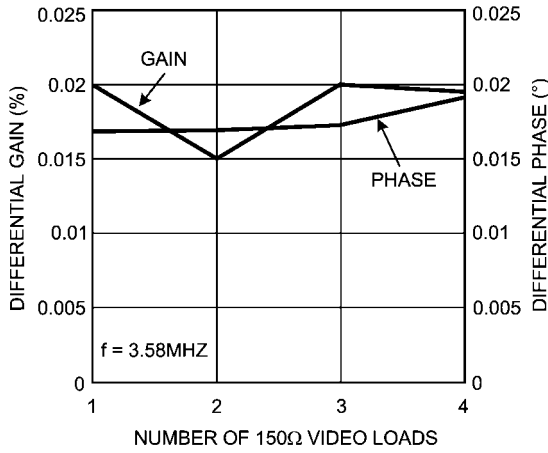

20151808

Differential Gain vs. Frequency

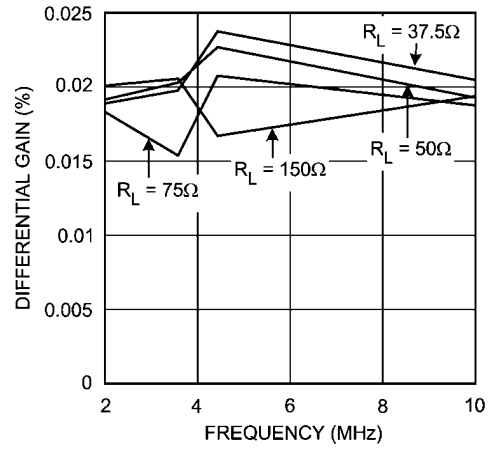

20151809

Differential Phase vs. Frequency

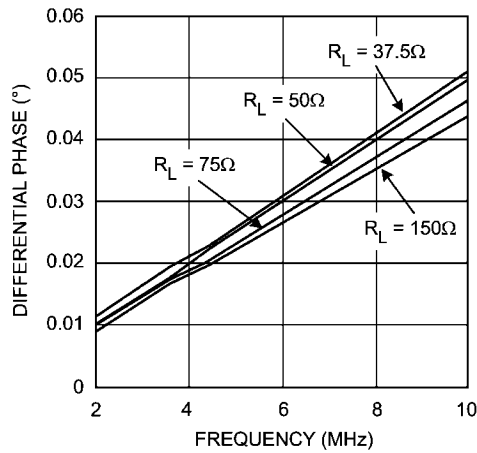

20151810

Gain Flatness & Linear Phase Deviation

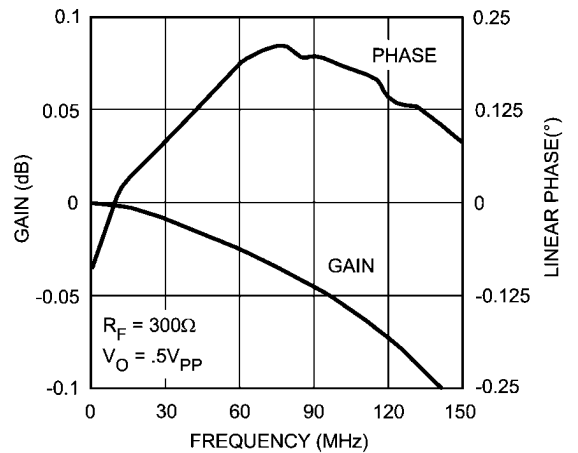

20151811

2nd Harmonic Distortion vs. Output Voltage

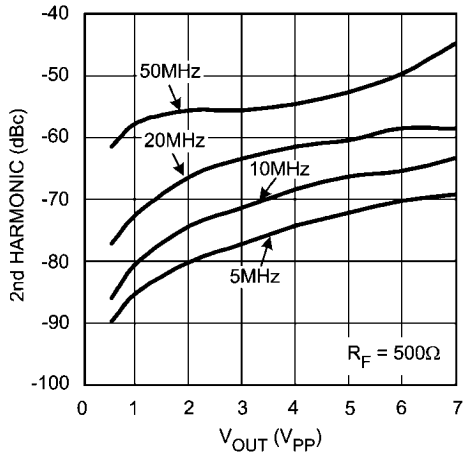

20151802

3rd Harmonic Distortion vs. Output Voltage

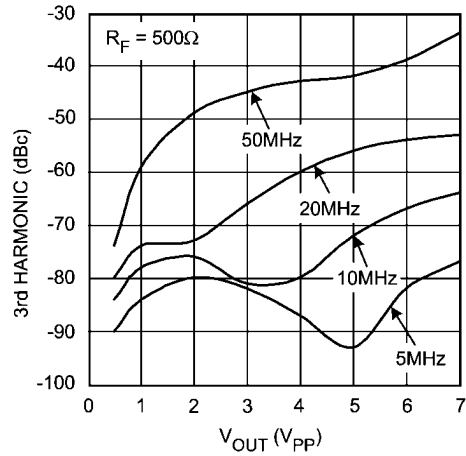

20151805

Closed Loop Output Resistance

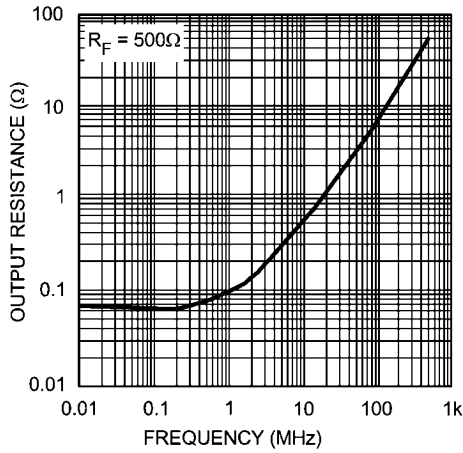

20151806

PSRR & CMRR

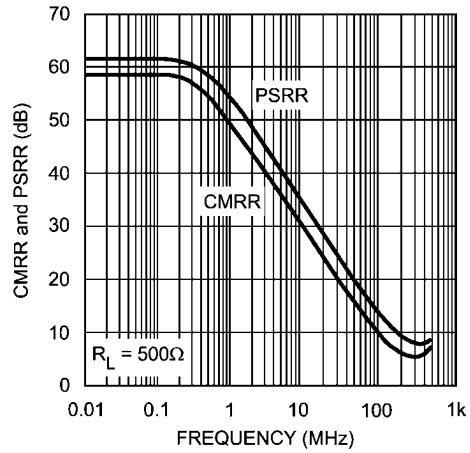

20151817

Suggested R_S vs. C_L

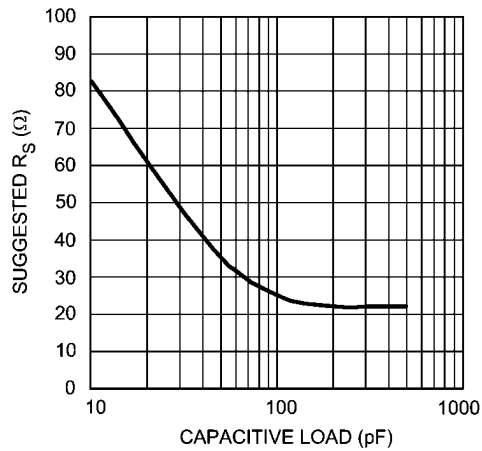

20151827

Application Section

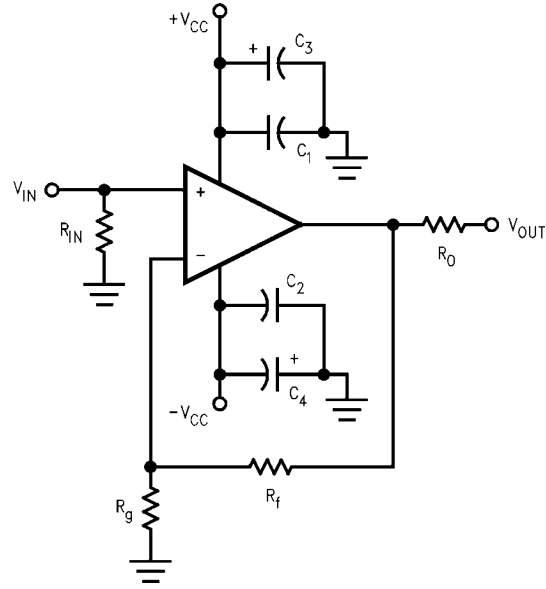

20151835

FIGURE 1. Non-Inverting Configuration with Power Supply Bypassing

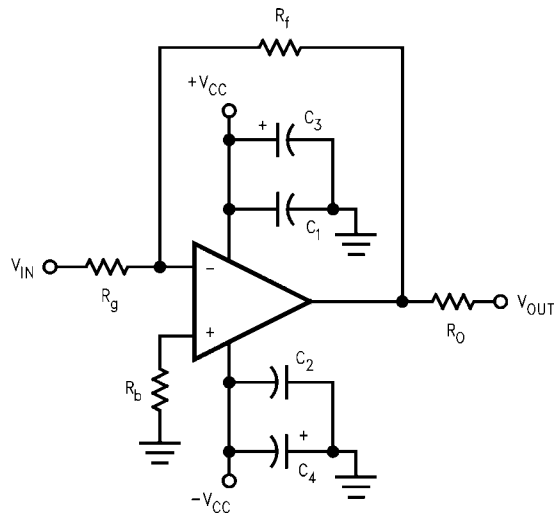

20151837

FIGURE 2. Inverting Configuration with Power Supply Bypassing

Application Introduction

Offered in an 8-pin package for reduced space and cost, the wideband LMH6715 dual current-feedback op amp provides closely matched DC and AC electrical performance characteristics making the part an ideal choice for wideband signal processing. Applications such as broadcast quality video systems, IQ amplifiers, filter blocks, high speed peak detectors, integrators and transimpedance amplifiers will all find superior performance in the LMH6715 dual op amp.

FEEDBACK RESISTOR SELECTION

One of the key benefits of a current feedback operational amplifier is the ability to maintain optimum frequency response independent of gain by using appropriate values for the feedback resistor (R_F). The Electrical Characteristics and Typical Performance plots specify an R_F of 500Ω , a gain of $+2V/V$ and $\pm 5V$ power supplies (unless otherwise specified). Generally, lowering R_F from its recommended value will peak the frequency response and extend the bandwidth while increasing the value of R_F will cause the frequency response to roll off faster. Reducing the value of R_F too far below its recommended value will cause overshoot, ringing and, eventually, oscillation.

Frequency Response vs. R_F

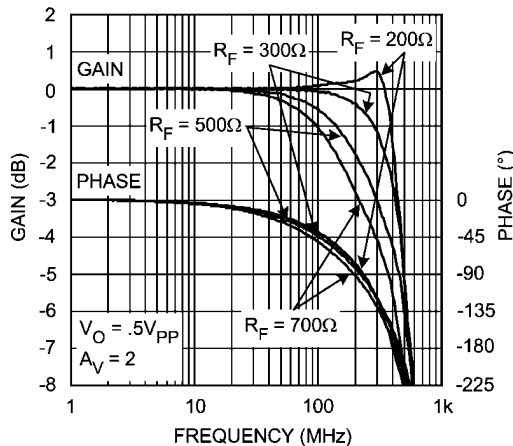

20151814

The plot labeled “Frequency Response vs. R_F ” shows the LMH6715’s frequency response as R_F is varied ($R_L = 100\Omega$, $A_V = +2$). This plot shows that an R_F of 200Ω results in peaking and marginal stability. An R_F of 300Ω gives near maximal bandwidth and gain flatness with good stability, but with very light loads ($R_L > 300\Omega$) the device may show some peaking. An R_F of 500Ω gives excellent stability with good bandwidth and is the recommended value for most applications. Since all applications are slightly different it is worth some experimentation to find the optimal R_F for a given circuit. For more information see Application Note OA-13 which describes the relationship between R_F and closed-loop frequency response for current feedback operational amplifiers.

When configuring the LMH6715 for gains other than $+2V/V$, it is usually necessary to adjust the value of the feedback resistor. The two plots labeled “ R_F vs. Non-inverting Gain” and “ R_F vs. Inverting Gain” provide recommended feedback resistor values for a number of gain selections.

R_F vs. Non-Inverting Gain

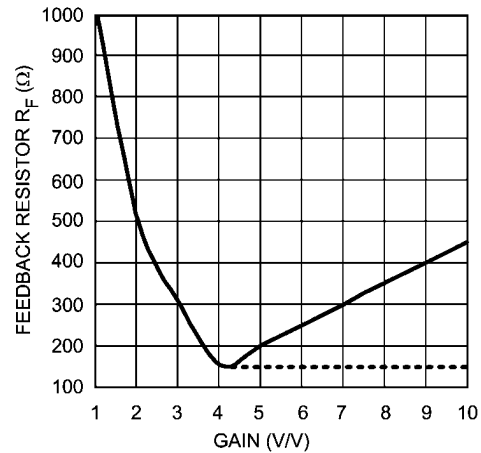

20151821

Both plots show the value of R_F approaching a minimum value (dashed line) at high gains. Reducing the feedback resistor below this value will result in instability and possibly oscillation. The recommended value of R_F is depicted by the solid line, which begins to increase at higher gains. The reason that a higher R_F is required at higher gains is the need to keep R_G from decreasing too far below the output impedance of the input buffer. For the LMH6715 the output resistance of the input buffer is approximately 160Ω and 50Ω is a practical lower limit for R_G . Due to the limitations on R_G the LMH6715 begins to operate in a gain bandwidth limited fashion for gains of $\pm 5V/V$ or greater.

R_F vs. Inverting Gain

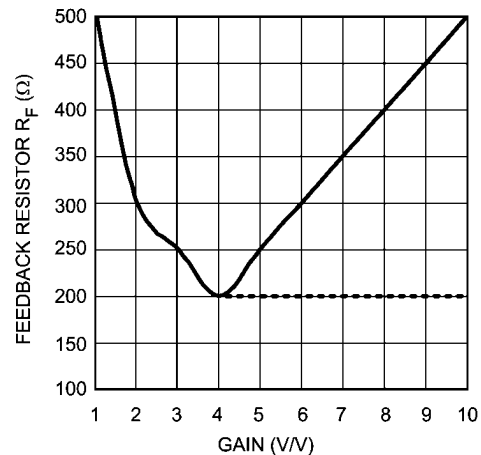

20151822

When using the LMH6715 as a replacement for the CLC412, identical bandwidth can be obtained by using an appropriate value of R_F . The chart “Frequency Response vs. R_F ” shows that an R_F of approximately 700Ω will provide bandwidth very close to that of the CLC412. At other gains a similar increase in R_F can be used to match the new and old parts.

CIRCUIT LAYOUT

With all high frequency devices, board layouts with stray capacitances have a strong influence over AC performance. The LMH6715 is no exception and its input and output pins are particularly sensitive to the coupling of parasitic capacitances (to AC ground) arising from traces or pads placed too closely ($<0.1''$) to power or ground planes. In some cases, due to the frequency response peaking caused by these para-

sitics, a small adjustment of the feedback resistor value will serve to compensate the frequency response. Also, it is very important to keep the parasitic capacitance across the feedback resistor to an absolute minimum.

The performance plots in the data sheet can be reproduced using the evaluation boards available from National. The CLC730036 board uses all SMT parts for the evaluation of the LMH6715. The board can serve as an example layout for the final production printed circuit board.

Care must also be taken with the LMH6715's layout in order to achieve the best circuit performance, particularly channel-to-channel isolation. The decoupling capacitors (both tantalum and ceramic) must be chosen with good high frequency characteristics to decouple the power supplies and the physical placement of the LMH6715's external components is critical. Grouping each amplifier's external components with their own ground connection and separating them from the external components of the opposing channel with the maximum possible distance is recommended. The input (R_{IN}) and gain setting resistors (R_F) are the most critical. It is also recommended that the ceramic decoupling capacitor (0.1 μ F chip or radial-leaded with low ESR) should be placed as closely to the power pins as possible.

POWER DISSIPATION

Follow these steps to determine the Maximum power dissipation for the LMH6715:

1. Calculate the quiescent (no-load) power: $P_{AMP} = I_{CC} (V_{CC} - V_{EE})$
2. Calculate the RMS power at the output stage: $P_O = (V_{CC} - V_{LOAD})(I_{LOAD})$, where V_{LOAD} and I_{LOAD} are the voltage and current across the external load.
3. Calculate the total RMS power: $P_t = P_{AMP} + P_O$

The maximum power that the LMH6715, package can dissipate at a given temperature can be derived with the following equation:

$P_{max} = (150^\circ - T_{amb}) / \theta_{JA}$, where T_{amb} = Ambient temperature ($^\circ$ C) and θ_{JA} = Thermal resistance, from junction to ambient, for a given package ($^\circ$ C/W). For the SOIC package θ_{JA} is 145 $^\circ$ C/W.

MATCHING PERFORMANCE

With proper board layout, the AC performance match between the two LMH6715's amplifiers can be tightly controlled as shown in Typical Performance plot labeled "Small-Signal Channel Matching".

The measurements were performed with SMT components using a feedback resistor of 300 Ω at a gain of +2V/V.

The LMH6715's amplifiers, built on the same die, provide the advantage of having tightly matched DC characteristics.

SLEW RATE AND SETTling TIME

One of the advantages of current-feedback topology is an inherently high slew rate which produces a wider full power bandwidth. The LMH6715 has a typical slew rate of 1300V/ μ s. The required slew rate for a design can be calculated by the following equation: $SR = 2\pi f V_{pk}$.

Careful attention to parasitic capacitances is critical to achieving the best settling time performance. The LMH6715 has a typical short term settling time to 0.05% of 12ns for a 2V step.

Also, the amplifier is virtually free of any long term thermal tail effects at low gains.

When measuring settling time, a solid ground plane should be used in order to reduce ground inductance which can cause common-ground-impedance coupling. Power supply and ground trace parasitic capacitances and the load capacitance will also affect settling time.

Placing a series resistor (R_S) at the output pin is recommended for optimal settling time performance when driving a capacitive load. The Typical Performance plot labeled " R_S and Settling Time vs. Capacitive Load" provides a means for selecting a value of R_S for a given capacitive load.

DC & NOISE PERFORMANCE

A current-feedback amplifier's input stage does not have equal nor correlated bias currents, therefore they cannot be canceled and each contributes to the total DC offset voltage at the output by the following equation:

$$V_{OFFSET} = \pm \left[I_{BN} \times R_S \left[1 + \frac{R_f}{R_g} \right] + V_{IO} \left[1 + \frac{R_f}{R_g} \right] + I_{BI} \times R_f \right]$$

The input resistance is the resistance looking from the non-inverting input back toward the source. For inverting DC-offset calculations, the source resistance seen by the input resistor R_g must be included in the output offset calculation as a part of the non-inverting gain equation. Application note OA-7 gives several circuits for DC offset correction. The noise currents for the inverting and non-inverting inputs are graphed in the Typical Performance plot labeled "Equivalent Input Noise". A more complete discussion of amplifier input-referred noise and external resistor noise contribution can be found in OA-12.

DIFFERENTIAL GAIN & PHASE

The LMH6715 can drive multiple video loads with very low differential gain and phase errors. The Typical Performance plots labeled "Differential Gain vs. Frequency" and "Differential Phase vs. Frequency" show performance for loads from 1 to 4. The Electrical Characteristics table also specifies performance for one 150 Ω load at 4.43MHz. For NTSC video, the performance specifications also apply. Application note OA-24 "Measuring and Improving Differential Gain & Differential Phase for Video", describes in detail the techniques used to measure differential gain and phase.

I/O VOLTAGE & OUTPUT CURRENT

The usable common-mode input voltage range (CMIR) of the LMH6715 specified in the Electrical Characteristics table of the data sheet shows a range of ± 2.2 volts. Exceeding this range will cause the input stage to saturate and clip the output signal.

The output voltage range is determined by the load resistor and the choice of power supplies. With ± 5 volts the class A/B output driver will typically drive ± 3.9 V into a load resistance of 100 Ω . Increasing the supply voltages will change the common-mode input and output voltage swings while at the same time increase the internal junction temperature.

Applications Circuits

SINGLE-TO-DIFFERENTIAL LINE DRIVER

The LMH6715's well matched AC channel-response allows a single-ended input to be transformed to highly matched push-pull driver. From a 1V single-ended input the circuit of [Figure 3](#) produces 1V differential signal between the two outputs. For larger signals the input voltage divider ($R_1 = 2R_2$) is necessary to limit the input voltage on channel 2.

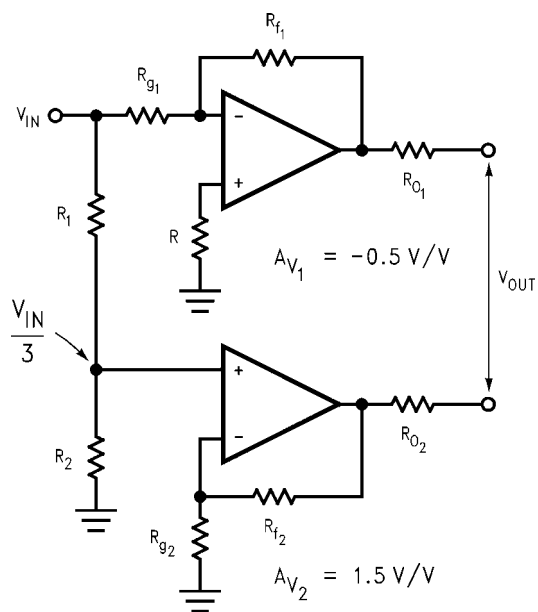

20151845

FIGURE 3. Single-to-Differential Line Driver

DIFFERENTIAL LINE RECEIVER

[Figure 4](#) and [Figure 5](#) show two different implementations of an instrumentation amplifier which convert differential signals to single-ended. [Figure 5](#) allows CMRR adjustment through R_2 .

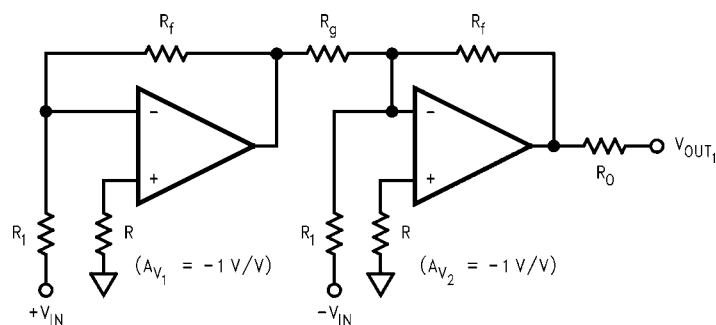

20151846

FIGURE 4. Differential Line Receiver

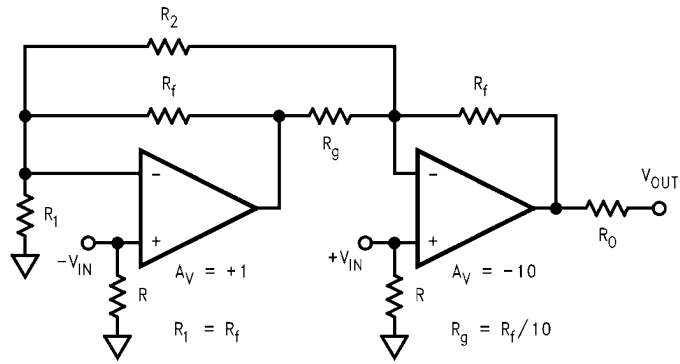

20151847

FIGURE 5. Differential Line Receiver with CMRR Adjustment

NON-INVERTING CURRENT-FEEDBACK INTEGRATOR

The circuit of *Figure 6* achieves its high speed integration by placing one of the LMH6715's amplifiers in the feedback loop of the second amplifier configured as shown.

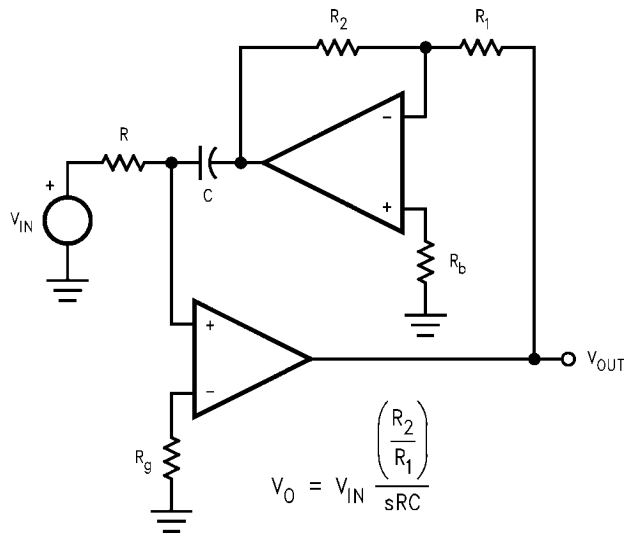

20151849

FIGURE 6. Current Feedback Integrator

LOW NOISE WIDE-BANDWIDTH TRANSIMPEDANCE AMPLIFIER

Figure 7 implements a low noise transimpedance amplifier using both channels of the LMH6715. This circuit takes advantage of the lower input bias current noise of the non-inverting input and achieves negative feedback through the second LMH6715 channel. The output voltage is set by the value of R_f while frequency compensation is achieved through the adjustment of R_T .

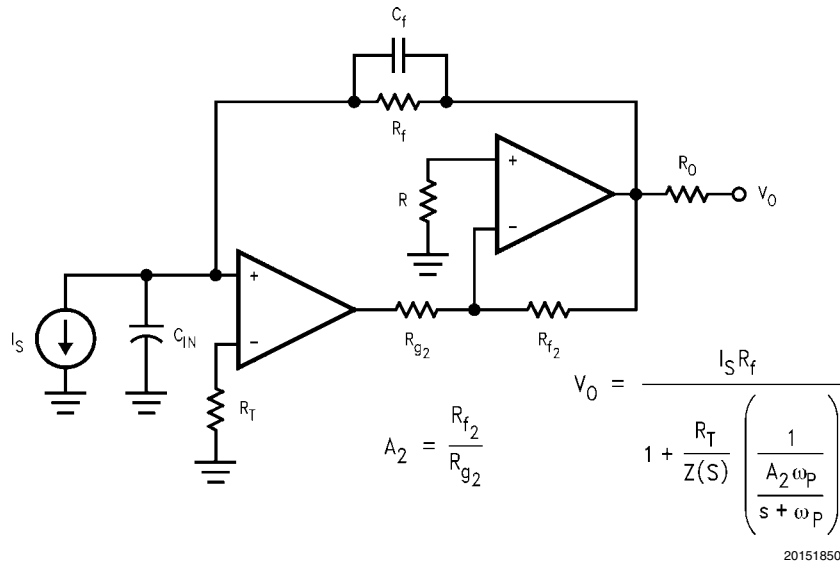
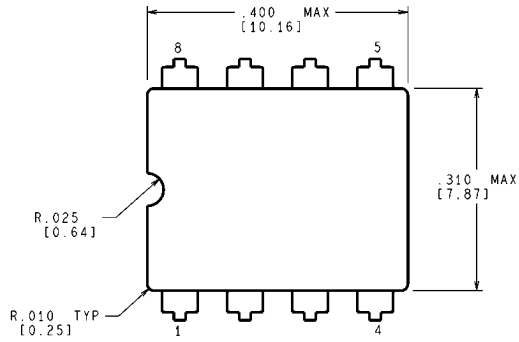

FIGURE 7. Low-Noise, Wide Bandwidth, Transimpedance Amp.

Revision History

Date Released	Revision	Section	Changes
11/30/2010	A	New Corporate Format Release	1 MDS data sheets converted into a Corp. data sheet format. Following MDS data sheet will be Archived MNLHM6715-X-RH, Rev. 0A0
07/12/2011	B	Connection Diagrams	Replaced 8 Lead Cerdip (J) diagram depicting single Op Amp with diagram depicting dual Op Amp.

Physical Dimensions inches (millimeters) unless otherwise noted



CONTROLLING DIMENSION IS INCH
VALUES IN [] ARE MILLIMETERS

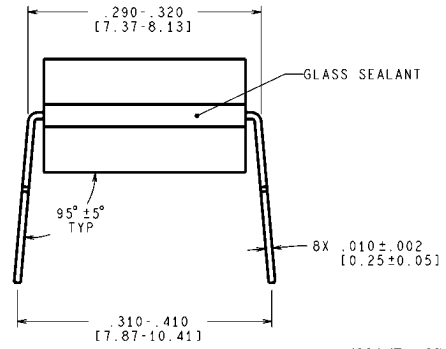
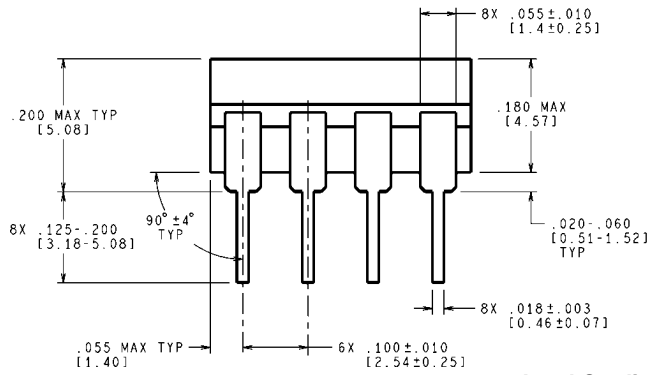

J08A (Rev M)

8 Lead Cerdip (J)
NS Package Number J08A

Notes

For more National Semiconductor product information and proven design tools, visit the following Web sites at:
www.national.com

Products		Design Support	
Amplifiers	www.national.com/amplifiers	WEBENCH® Tools	www.national.com/webench
Audio	www.national.com/audio	App Notes	www.national.com/appnotes
Clock and Timing	www.national.com/timing	Reference Designs	www.national.com/refdesigns
Data Converters	www.national.com/adc	Samples	www.national.com/samples
Interface	www.national.com/interface	Eval Boards	www.national.com/evalboards
LVDS	www.national.com/lvds	Packaging	www.national.com/packaging
Power Management	www.national.com/power	Green Compliance	www.national.com/quality/green
Switching Regulators	www.national.com/switchers	Distributors	www.national.com/contacts
LDOs	www.national.com/ldo	Quality and Reliability	www.national.com/quality
LED Lighting	www.national.com/led	Feedback/Support	www.national.com/feedback
Voltage References	www.national.com/vref	Design Made Easy	www.national.com/easy
PowerWise® Solutions	www.national.com/powerwise	Applications & Markets	www.national.com/solutions
Serial Digital Interface (SDI)	www.national.com/sdi	Mil/Aero	www.national.com/milaero
Temperature Sensors	www.national.com/tempensors	SolarMagic™	www.national.com/solarmagic
PLL/VCO	www.national.com/wireless	PowerWise® Design University	www.national.com/training

THE CONTENTS OF THIS DOCUMENT ARE PROVIDED IN CONNECTION WITH NATIONAL SEMICONDUCTOR CORPORATION ("NATIONAL") PRODUCTS. NATIONAL MAKES NO REPRESENTATIONS OR WARRANTIES WITH RESPECT TO THE ACCURACY OR COMPLETENESS OF THE CONTENTS OF THIS PUBLICATION AND RESERVES THE RIGHT TO MAKE CHANGES TO SPECIFICATIONS AND PRODUCT DESCRIPTIONS AT ANY TIME WITHOUT NOTICE. NO LICENSE, WHETHER EXPRESS, IMPLIED, ARISING BY ESTOPPEL OR OTHERWISE, TO ANY INTELLECTUAL PROPERTY RIGHTS IS GRANTED BY THIS DOCUMENT.

TESTING AND OTHER QUALITY CONTROLS ARE USED TO THE EXTENT NATIONAL DEEMS NECESSARY TO SUPPORT NATIONAL'S PRODUCT WARRANTY. EXCEPT WHERE MANDATED BY GOVERNMENT REQUIREMENTS, TESTING OF ALL PARAMETERS OF EACH PRODUCT IS NOT NECESSARILY PERFORMED. NATIONAL ASSUMES NO LIABILITY FOR APPLICATIONS ASSISTANCE OR BUYER PRODUCT DESIGN. BUYERS ARE RESPONSIBLE FOR THEIR PRODUCTS AND APPLICATIONS USING NATIONAL COMPONENTS. PRIOR TO USING OR DISTRIBUTING ANY PRODUCTS THAT INCLUDE NATIONAL COMPONENTS, BUYERS SHOULD PROVIDE ADEQUATE DESIGN, TESTING AND OPERATING SAFEGUARDS.

EXCEPT AS PROVIDED IN NATIONAL'S TERMS AND CONDITIONS OF SALE FOR SUCH PRODUCTS, NATIONAL ASSUMES NO LIABILITY WHATSOEVER, AND NATIONAL DISCLAIMS ANY EXPRESS OR IMPLIED WARRANTY RELATING TO THE SALE AND/OR USE OF NATIONAL PRODUCTS INCLUDING LIABILITY OR WARRANTIES RELATING TO FITNESS FOR A PARTICULAR PURPOSE, MERCHANTABILITY, OR INFRINGEMENT OF ANY PATENT, COPYRIGHT OR OTHER INTELLECTUAL PROPERTY RIGHT.

LIFE SUPPORT POLICY

NATIONAL'S PRODUCTS ARE NOT AUTHORIZED FOR USE AS CRITICAL COMPONENTS IN LIFE SUPPORT DEVICES OR SYSTEMS WITHOUT THE EXPRESS PRIOR WRITTEN APPROVAL OF THE CHIEF EXECUTIVE OFFICER AND GENERAL COUNSEL OF NATIONAL SEMICONDUCTOR CORPORATION. As used herein:

Life support devices or systems are devices which (a) are intended for surgical implant into the body, or (b) support or sustain life and whose failure to perform when properly used in accordance with instructions for use provided in the labeling can be reasonably expected to result in a significant injury to the user. A critical component is any component in a life support device or system whose failure to perform can be reasonably expected to cause the failure of the life support device or system or to affect its safety or effectiveness.

National Semiconductor and the National Semiconductor logo are registered trademarks of National Semiconductor Corporation. All other brand or product names may be trademarks or registered trademarks of their respective holders.

Copyright© 2011 National Semiconductor Corporation

For the most current product information visit us at www.national.com



**National Semiconductor
Americas Technical
Support Center**
Email: support@nsc.com
Tel: 1-800-272-9959

**National Semiconductor Europe
Technical Support Center**
Email: europe.support@nsc.com

**National Semiconductor Asia
Pacific Technical Support Center**
Email: ap.support@nsc.com

**National Semiconductor Japan
Technical Support Center**
Email: jpn.feedback@nsc.com

IMPORTANT NOTICE

Texas Instruments Incorporated and its subsidiaries (TI) reserve the right to make corrections, modifications, enhancements, improvements, and other changes to its products and services at any time and to discontinue any product or service without notice. Customers should obtain the latest relevant information before placing orders and should verify that such information is current and complete. All products are sold subject to TI's terms and conditions of sale supplied at the time of order acknowledgment.

TI warrants performance of its hardware products to the specifications applicable at the time of sale in accordance with TI's standard warranty. Testing and other quality control techniques are used to the extent TI deems necessary to support this warranty. Except where mandated by government requirements, testing of all parameters of each product is not necessarily performed.

TI assumes no liability for applications assistance or customer product design. Customers are responsible for their products and applications using TI components. To minimize the risks associated with customer products and applications, customers should provide adequate design and operating safeguards.

TI does not warrant or represent that any license, either express or implied, is granted under any TI patent right, copyright, mask work right, or other TI intellectual property right relating to any combination, machine, or process in which TI products or services are used. Information published by TI regarding third-party products or services does not constitute a license from TI to use such products or services or a warranty or endorsement thereof. Use of such information may require a license from a third party under the patents or other intellectual property of the third party, or a license from TI under the patents or other intellectual property of TI.

Reproduction of TI information in TI data books or data sheets is permissible only if reproduction is without alteration and is accompanied by all associated warranties, conditions, limitations, and notices. Reproduction of this information with alteration is an unfair and deceptive business practice. TI is not responsible or liable for such altered documentation. Information of third parties may be subject to additional restrictions.

Resale of TI products or services with statements different from or beyond the parameters stated by TI for that product or service voids all express and any implied warranties for the associated TI product or service and is an unfair and deceptive business practice. TI is not responsible or liable for any such statements.

TI products are not authorized for use in safety-critical applications (such as life support) where a failure of the TI product would reasonably be expected to cause severe personal injury or death, unless officers of the parties have executed an agreement specifically governing such use. Buyers represent that they have all necessary expertise in the safety and regulatory ramifications of their applications, and acknowledge and agree that they are solely responsible for all legal, regulatory and safety-related requirements concerning their products and any use of TI products in such safety-critical applications, notwithstanding any applications-related information or support that may be provided by TI. Further, Buyers must fully indemnify TI and its representatives against any damages arising out of the use of TI products in such safety-critical applications.

TI products are neither designed nor intended for use in military/aerospace applications or environments unless the TI products are specifically designated by TI as military-grade or "enhanced plastic." Only products designated by TI as military-grade meet military specifications. Buyers acknowledge and agree that any such use of TI products which TI has not designated as military-grade is solely at the Buyer's risk, and that they are solely responsible for compliance with all legal and regulatory requirements in connection with such use.

TI products are neither designed nor intended for use in automotive applications or environments unless the specific TI products are designated by TI as compliant with ISO/TS 16949 requirements. Buyers acknowledge and agree that, if they use any non-designated products in automotive applications, TI will not be responsible for any failure to meet such requirements.

Following are URLs where you can obtain information on other Texas Instruments products and application solutions:

Products

Audio	www.ti.com/audio
Amplifiers	amplifier.ti.com
Data Converters	dataconverter.ti.com
DLP® Products	www.dlp.com
DSP	dsp.ti.com
Clocks and Timers	www.ti.com/clocks
Interface	interface.ti.com
Logic	logic.ti.com
Power Mgmt	power.ti.com
Microcontrollers	microcontroller.ti.com
RFID	www.ti-rfid.com
OMAP Mobile Processors	www.ti.com/omap
Wireless Connectivity	www.ti.com/wirelessconnectivity

Applications

Communications and Telecom	www.ti.com/communications
Computers and Peripherals	www.ti.com/computers
Consumer Electronics	www.ti.com/consumer-apps
Energy and Lighting	www.ti.com/energy
Industrial	www.ti.com/industrial
Medical	www.ti.com/medical
Security	www.ti.com/security
Space, Avionics and Defense	www.ti.com/space-avionics-defense
Transportation and Automotive	www.ti.com/automotive
Video and Imaging	www.ti.com/video

TI E2E Community Home Page

e2e.ti.com

Mailing Address: Texas Instruments, Post Office Box 655303, Dallas, Texas 75265
Copyright © 2011, Texas Instruments Incorporated