

HD3SS215 6.0 Gbps HDMI DisplayPort 2:1/1:2 Differential Switch

1 Features

- General Purpose 2:1/1:2 Differential Switch
- Compatible With DisplayPort Electrical Standard
- Compatible With HDMI Electrical Standards
- 2:1 and 1:2 Switching Supporting Data Rates up to 6 Gbps
- Supports HPD Switching
- Supports AUX and DDC Switching
- Wide –3-dB Differential Bandwidth of 7 GHz
- Excellent Dynamic Characteristics (at 3 GHz)
 - Crosstalk = –35 dB
 - Isolation = –21 dB
 - Insertion Loss = –1.6 dB
 - Return Loss = –12 dB
 - Max Bit-Bit Skew = 5 ps
- VDD Operating Range 3.3 V \pm 10%
- Commercial Temperature Range: 0°C to 70°C (HD3SS215)
- Industrial Temperature Range: –40°C to 85°C (HD3SS215I)
- Package Options:
 - 5 mm x 5 mm, 50-Ball ZQE
 - 8 mm x 8 mm, 56-Pin RTQ
- Output Enable (OE) Pin Disables Switch to Save Power
- Power Consumption:
 - Active < 9 mW Typical
 - Standby < 30 μ W Maximum (When OE = L)

2 Applications

- Desktop and Notebook Applications:
 - PCI Express Gen 1, Gen 2 Switching
 - DP Switching
 - HDMI Switching
 - LVDS Switching
- Docking
- UHDTV, HDTV and Monitors
- Set Top Boxes
- AVRs, Blu-Ray, DVD players

3 Description

HD3SS215 is a high-speed wide common mode passive switch capable of supporting DisplayPort HBR2 and high definition multimedia interface (HDMI) applications requiring 4k2k 60Hz refresh rates. The HD3SS215 can be configured to support two sources to one sink or one source to two sinks. To support these video standards the HD3SS215 also switches the display data channel (DDC) and hot plug detect (HPD) signals for HDMI or digital video interface (DVI) applications. It also switches the auxiliary (AUX) and hot plug detect (HPD) signals for DisplayPort applications. The flexibility the HD3SS215 provides by supporting both wide common mode and AC or DC coupled links makes it ideal for many applications.

Device Information⁽¹⁾

PART NUMBER	PACKAGE	BODY SIZE (NOM)
HD3SS215,	μ BGA (50)	5.00 mm x 5.00 mm
HD3SS215I	QFN (56)	8.00 mm x 8.00 mm

(1) For all available packages, see the orderable addendum at the end of the datasheet.

Application Schematic

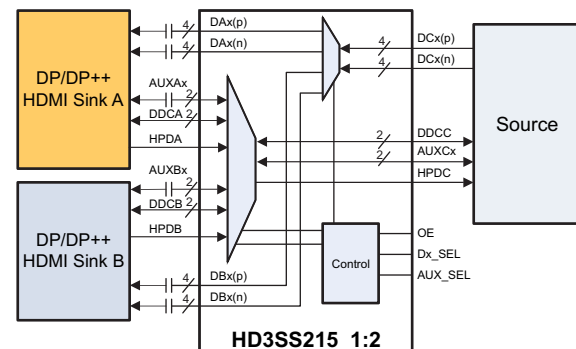
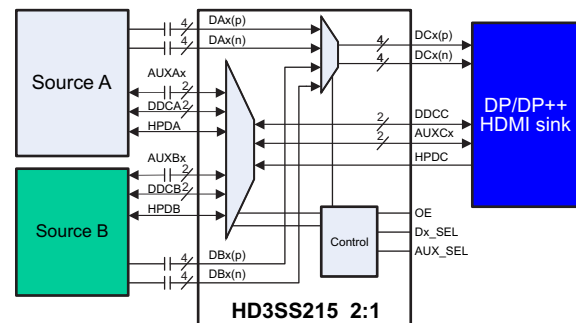

Table of Contents

1 Features	1	8.2 Functional Block Diagram	12
2 Applications	1	8.3 Feature Description	13
3 Description	1	8.4 Device Functional Modes	13
4 Revision History	2	9 Applications and Implementation	14
5 Description (Continued)	4	9.1 Application Information	14
6 Pin Configuration and Functions	4	9.2 Typical Applications	14
7 Specifications	7	10 Power Supply Recommendations	19
7.1 Absolute Maximum Ratings	7	11 Layout	19
7.2 ESD Ratings	7	11.1 Layout Guidelines	19
7.3 Recommended Operating Conditions	7	11.2 Layout Example	20
7.4 Thermal Information	7	12 Device and Documentation Support	22
7.5 Electrical Characteristics	8	12.1 Community Resources	22
7.6 Electrical Characteristics, Device Parameters	9	12.2 Trademarks	22
7.7 Switching Characteristics	9	12.3 Electrostatic Discharge Caution	22
7.8 Timing Diagrams	9	12.4 Glossary	22
8 Detailed Description	11	13 Mechanical, Packaging, and Orderable Information	22
8.1 Overview	11		

4 Revision History

Changes from Revision C (August 2015) to Revision D

Page

• Changed Description text string from "...DisplayPort 1.2a..." to "...DisplayPort HBR2..." and from "...HDMI2.0.." to "...HDMI..."	1
• Deleted $R_{\theta JC(bot)}$ spec from Thermal Information table as N/A	7
• Deleted "Operating free air temperature" spec from Electrical Characteristics table	8
• Changed Figure 8	18
• Changed Power Supply Recommendations text string from "Decoupling capacitors may be used to reduce noise and improve power supply integrity" to "Decoupling capacitors must be used to reduce power supply noise"	19

Changes from Revision B (July 2015) to Revision C

Page

• Added $t_{on(OE_L-H)}$, $t_{off(OE_H-L)}$, and t_{SWITCH_OVER} to the Switching Characteristics	9
--	----------

Changes from Revision A (May 2014) to Revision B

Page

• Changed the title From: "2.0/DisplayPort 1.2A" To: "DisplayPort"	1
• Changed Features list item From: Compatible With DisplayPort 1.2a Electrical Standard To: Compatible With DisplayPort Electrical Standard	1
• Changed Features list item From: Compatible With HDMI 1.4b and HDMI 2.0 Electrical Standards To: Compatible With HDMI Electrical Standards	1
• Added Features item: Commercial Temperature Range: –40°C to 70°C (HD3SS215)	1
• Added Features item: Industrial Temperature Range: –40°C to 85°C (HD3SS215I)	1
• Added Features , Package Options: 8 mm × 8 mm, 56-Pin RTQ	1
• Changed the Applications list item From: TV and Monitors To: UHD TV, HDTV and Monitors	1
• Added Description (Continued) paragraph.	4
• Added the 56-Pin QFN image	5
• Added RTQ column to the Pin Functions table	6
• Moved T_{stg} From: ESD Ratings To: Absolute Maximum Ratings ⁽¹⁾⁽²⁾	7
• Changed the Handling Ratings table to ESD Ratings table	7

- Added HD3SS2151I, Operating free-air temperature *Recommended Operating Conditions* 7
- Added RTQ 56 PIN values to the *Thermal Information*..... 7
- Added table Note " This pin can be driven.." to the *Electrical Characteristics* table 8
- Changed the *Electrical Characteristics, Device Parameters*⁽³⁾ table to include ZQE and RTQ package values..... 9
- Added the *Switching Characteristics* table 9
- Added section: *HDMI 2:1 Sink Application Using the RTQ Package* 18
- Added *Figure 11* 21

Changes from Original (May 2014) to Revision A
Page

- Changed *Description* section 1
- Changed *Figure 4* 14

5 Description (Continued)

One typical application would be a mother board that includes two GPUs that need to drive one DisplayPort sink. The GPU is selected by the Dx_SEL pin. Another application is when one source needs to switch between one of two sinks, such as a side connector and a docking station connector. The switching is controlled using the Dx_SEL and AUX_SEL pins. The HD3SS215I operates from a single supply voltage of 3.3 V, over full industrial temperature range –40°C to 85°C, in the ZQE package and 56 pin RTQ package.

6 Pin Configuration and Functions

50-Pin µBGA
ZQE Package
(Top View)

	1	2	3	4	5	6	7	8	9
A	Dx_SEL	VDD		DA0(n)	DA1(n)	DA2(n)		DA3(p)	DA3(n)
B	DC0(n)	DC0(p)	GND	DA0(p)	DA1(p)	DA2(p)	OE	DB0(p)	DB0(n)
C		AUX_SEL						GND	
D	DC1(n)	DC1(p)						DB1(p)	DB1(n)
E	DC2(n)	DC2(p)						DB2(p)	DB2(n)
F	DC3(n)	DC3(p)						DB3(p)	DB3(n)
G		GND						GND	
H	AUXC(n)	AUXC(p)	HPDB	GND	DDCCLK_B	AUXB(p)	GND	DDCCLK_A	AUXA(p)
J	HPDC	HPDA	DDCCLK_C	VDD	DDCDAT_B	AUXB(n)	DDCDAT_C	DDCDAT_A	AUXA(n)

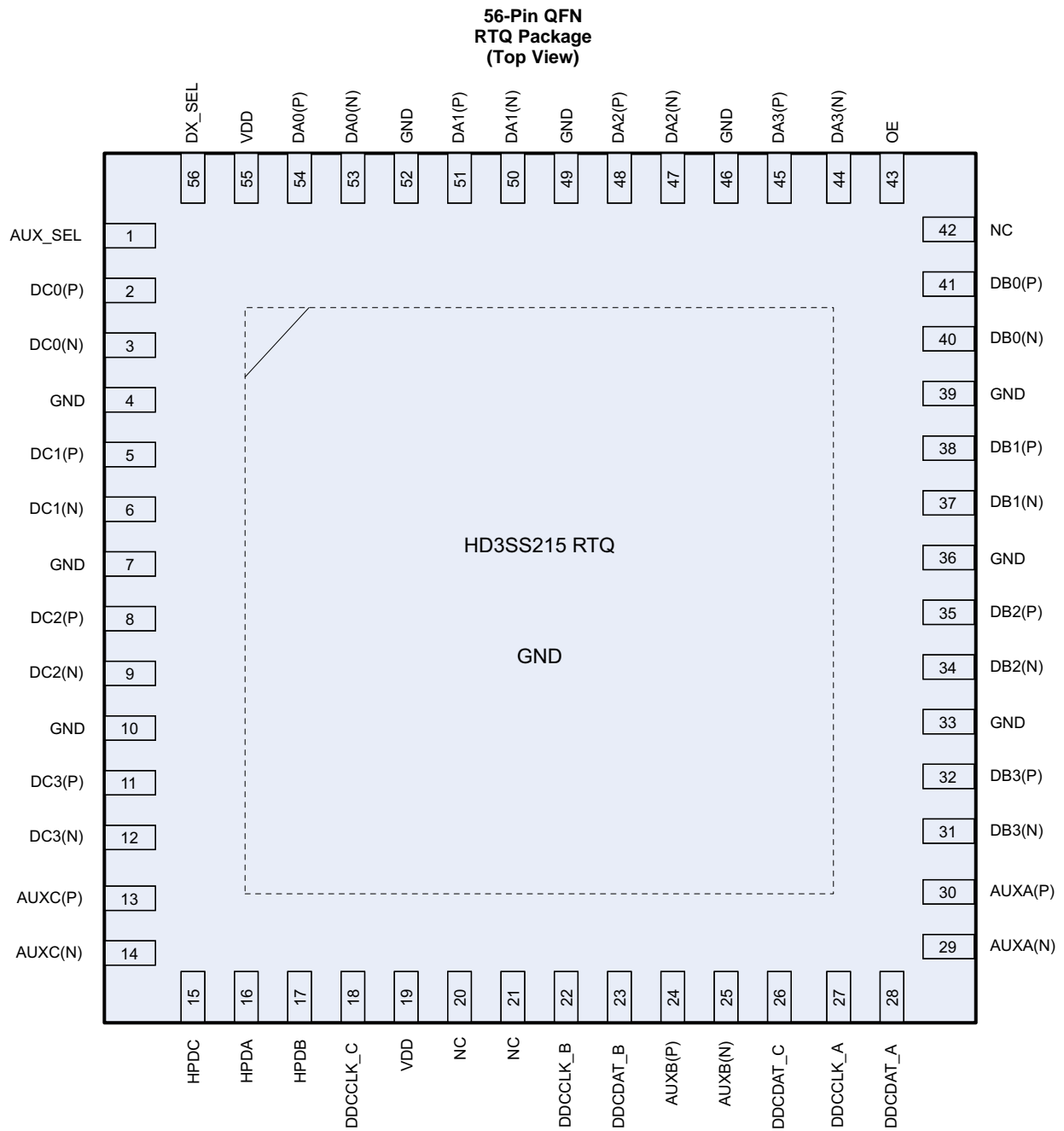

Pin Functions

NAME	PIN		I/O	DESCRIPTION ⁽¹⁾
	NO.			
	ZQE	RTQ		
Dx_SEL	A1	56	2 Level Control I	High Speed Port Selection Control Pins
AUX_SEL	C2	1	3 Level Control I	AUX/DDC Selection Control Pin in Conjunction with Dx_SEL Pin
DA0(p)	B4	54	I/O	Port A, Channel 0, High Speed Positive Signal
DA0(n)	A4	53		Port A, Channel 0, High Speed Negative Signal
DA1(p)	B5	51	I/O	Port A, Channel 1, High Speed Positive Signal
DA1(n)	A5	50		Port A, Channel 1, High Speed Negative Signal
DA2(p)	B6	48	I/O	Port A, Channel 2, High Speed Positive Signal
DA2(n)	A6	47		Port A, Channel 2, High Speed Negative Signal
DA3(p)	A8	45	I/O	Port A, Channel 3, High Speed Positive Signal
DA3(n)	A9	44		Port A, Channel 3, High Speed Negative Signal
DB0(p)	B8	41	I/O	Port B, Channel 0, High Speed Positive Signal
DB0(n)	B9	40		Port B, Channel 0, High Speed Negative Signal
DB1(p)	D8	38	I/O	Port B, Channel 1, High Speed Positive Signal
DB1(n)	D9	37		Port B, Channel 1, High Speed Negative Signal
DB2(p)	E8	35	I/O	Port B, Channel 2, High Speed Positive Signal
DB2(n)	E9	34		Port B, Channel 2, High Speed Negative Signal
DB3(p)	F8	32	I/O	Port B, Channel 3, High Speed Positive Signal
DB3(n)	F9	31		Port B, Channel 3, High Speed Negative Signal
DC0(p)	B2	2	I/O	Port C, Channel 0, High Speed Positive Signal
DC0(n)	B1	3		Port C, Channel 0, High Speed Negative Signal
DC1(p)	D2	5	I/O	Port C, Channel 1, High Speed Positive Signal
DC1(n)	D1	6		Port C, Channel 1, High Speed Negative Signal
DC2(p)	E2	8	I/O	Port C, Channel 2, High Speed Positive Signal
DC2(n)	E1	9		Port C, Channel 2, High Speed Negative Signal
DC3(p)	F2	11	I/O	Port C, Channel 3, High Speed Positive Signal
DC3(n)	F1	12		Port C, Channel 3, High Speed Negative Signal
AUXA(p)	H9	30	I/O	Port A AUX Positive Signal
AUXA(n)	J9	29		Port A AUX Negative Signal
AUXB(p)	H6	24	I/O	Port B AUX Positive Signal
AUXB(n)	J6	25		Port B AUX Negative Signal
AUXC(p)	H2	13	I/O	Port C AUX Positive Signal
AUXC(n)	H1	14		Port C AUX Negative Signal
DDCCLK_A	H8	27	I/O	Port A DDC Clock Signal
DDCDAT_A	J8	28		Port A DDC Data Signal
DDCCLK_B	H5	22	I/O	Port B DDC Clock Signal
DDCDAT_B	J5	23		Port B DDC Data Signal
DDCCLK_C	J3	18	I/O	Port C DDC Clock Signal
DDCDAT_C	J7	26		Port C DDC Data Signal
HPDA/B/C	J2, H3, J1	16, 17, 15	I/O	Port A/B/C Hot Plug Detect
OE	B7	43	I	Output Enable: OE = VIH: Normal Operation OE = VIL: Standby Mode
VDD	A2, J4	19, 55	Supply	3.3 V Positive power supply voltage
GND	B3, C8, G2, G8 H4, H7	4, 7, 10, 33, 36, 39, 46, 49, 52	Supply	Ground
NC		20, 21, 42		Not connected
Thermal Pad	–	–	GND	Supply Ground

(1) Only the high speed data DAz/DBz ports incorporate 20kΩ pull down resistors that are switched in when a port is not selected and switched out when the port is selected.

7 Specifications

7.1 Absolute Maximum Ratings⁽¹⁾⁽²⁾

over operating free-air temperature range (unless otherwise noted)

		VALUE		UNIT
		MIN	MAX	
Supply voltage	V _{DD}	-0.5	4	V
Voltage	Differential I/O	-0.5	4	V
	AUX_SEL, Dx_SEL	-0.5	4	
	HPD _x , DDCCLK_X, DDCDAT_X	-0.5	6	
T _{stg}	Storage temperature	-65	150	°C

- (1) Stresses beyond those listed under absolute maximum ratings may cause permanent damage to the device. These are stress ratings only and functional operation of the device at these or any conditions beyond those indicated under recommended operating conditions is not implied. Exposure to absolute-maximum-rated conditions for extended periods may affect device reliability.
- (2) All voltage values, except differential voltages, are with respect to network ground pin.

7.2 ESD Ratings

			VALUE	UNIT
V _(ESD)	Electrostatic discharge	Human body model (HBM), per ANSI/ESDA/JEDEC JS-001, all pins ⁽¹⁾	±1500	V
		Charged device model (CDM), per JEDEC specification JESD22-C101, all pins ⁽²⁾	±1250	V

- (1) JEDEC document JEP155 states that 500-V HBM allows safe manufacturing with a standard ESD control process.
- (2) JEDEC document JEP157 states that 250-V CDM allows safe manufacturing with a standard ESD control process.

7.3 Recommended Operating Conditions

over operating free-air temperature range (unless otherwise noted)

			MIN	NOM	MAX	UNIT
V _{DD}	Main power supply		3	3.3	3.6	V
T _A	Operating free-air temperature	HD3SS215	0		70	°C
		HD3SS215I	-40		85	°C
C _{AC}	AC coupling capacitor		75	100	200	nF

7.4 Thermal Information

THERMAL METRIC ⁽¹⁾		HD3SS215		UNIT
		RTQ (56 PIN)	ZQE (50 PIN)	
R _{θJA}	Junction-to-ambient thermal resistance	90.5	71.6	°C/W
R _{θJC(top)}	Junction-to-case (top) thermal resistance	41.9	44.1	°C/W
R _{θJB}	Junction-to-board thermal resistance	53.9	49.0	°C/W
ψ _{JT}	Junction-to-top characterization parameter	1.8	2.7	°C/W
ψ _{JB}	Junction-to-board characterization parameter	53.4	49.0	°C/W

- (1) For more information about traditional and new thermal metrics, see the *IC Package Thermal Metrics* application report, [SPRA953](#).

7.5 Electrical Characteristics

Typical values for all parameters are at $V_{DD} = 3.3\text{ V}$ and $T_A = 25^\circ\text{C}$. All temperature limits are specified by design.

PARAMETER		TEST CONDITIONS	MIN	TYP	MAX	UNIT
V_{DD}	Supply voltage		3	3.3	3.6	V
V_{IH}	Input high voltage	Control Pins, Signal Pins (Dx_SEL, AUX_SEL, OE)	2		V_{DD}	V
		HPD and DDC	2		5.5	
V_{IM}	Input mid level voltage	AUX_SEL Pin ⁽¹⁾	$\frac{V_{DD}}{2} - 300\text{mV}$	$V_{DD}/2$	$\frac{V_{DD}}{2} + 300\text{mV}$	V
V_{IL}	Input low voltage	Control Pins, Signal Pins (Dx_SEL, AUX_SEL, OE)	-0.1		0.8	V
V_{I/O_Diff}	Differential voltage (Dx, AUXx)	Switch I/O diff voltage	0		1.8	V _{pp}
V_{CM}	Common voltage (Dx, AUXx)	Switch common mode voltage	0		3.3	V
I_{IH}	Input high current (Dx_SEL, AUX_SEL)	$V_{DD} = 3.6\text{ V}$, $V_{IN} = V_{DD}$			1	μA
I_{IM}	Input mid current (AUX_SEL)	$V_{DD} = 3.6\text{ V}$, $V_{IN} = V_{DD}/2$			1	
I_{IL}	Input low current (Dx_SEL, AUX_SEL)	$V_{DD} = 3.6\text{ V}$, $V_{IN} = \text{GND}$		0.01	1	
I_{LK}	Leakage current (Dx_SEL, AUX_SEL)	$V_{DD} = 3.6\text{ V}$, $V_{IN} = 2\text{ V}$, OE = 3.3 V		0.01	2	
		$V_{DD} = 3.6\text{ V}$, $V_{IN} = 2\text{ V}$, OE = 0 V		0.01	2	
	Leakage current (HPDx/DDCx)	$V_{DD} = 3.6\text{ V}$, $V_{IN} = 2\text{ V}$, OE = 0 V; Dx_SEL = 3.3 V		0.01	5	
		$V_{DD} = 3.6\text{ V}$, $V_{IN} = 2\text{ V}$, OE = 3.3 V; Dx_SEL = GND		0.01	5	
I_{OFF}	Device shut down current	$V_{DD} = 3.6\text{ V}$, OE = GND			8	
I_{DD}	Supply current	$V_{DD} = 3.6\text{ V}$, Dx_SEL = V_{DD} ; AUX_SEL = GND; Outputs Floating		2.5	3.2	mA
DA, DB, DC HIGH SPEED SIGNAL PATH						
R_{ON}	ON resistance	$V_{CM} = 0\text{ V} - 3.3\text{ V}$, $I_O = -1\text{ mA}$		8	14	Ω
ΔR_{ON}	On resistance match between pairs of the same channel	$V_{CM} = 0\text{ V} - 3.3\text{ V}$, $I_O = -1\text{ mA}$			1.5	Ω
R_{FLAT_ON}	On resistance flatness ($R_{ON(MAX)} - R_{ON(MAIN)}$)	$V_{CM} = 0\text{ V} - 3.3\text{ V}$		1.3		Ω
AUXx, DDC, SIGNAL PATH						
$R_{ON(AUX)}$	ON resistance on AUX channel	$V_{CM} = 0\text{ V} - 3.3\text{ V}$, $I_O = -8\text{ mA}$		5	8	Ω
$R_{ON(DDC)}$	ON resistance on DDC channel	$V_{CM} = 0.4\text{ V}$, $I_O = -3\text{ mA}$		30	40	Ω

(1) This pin can be driven to the specified level or 10 k Ω . Pull up and pull downs can be used. It cannot be left floating.

7.6 Electrical Characteristics, Device Parameters⁽¹⁾

Under recommended operating conditions; R_{LOAD} , $R_{SC} = 50 \Omega$ (unless otherwise noted)

PARAMETER		TEST CONDITIONS	MIN	TYP	MAX	UNIT
RL	Dx Differential return loss	ZQE package	1.35 GHz	-15		dB
			3 GHz	-12		
		RTQ package	1.35 GHz	-17		
			3 GHz	-13		
X _{TALK}	Dx Differential crosstalk	ZQE package	2.7 GHz	-35		dB
		RTQ package		-35		
O _{IRR}	Dx Differential off-isolation	ZQE package	3 GHz	-21		dB
		RTQ package		-16		
I _L	Dx Differential insertion loss	ZQE package	f = 1.35 GHz	-1.2		dB
			f = 3 GHz	-1.6		
		RTQ package	f = 1.35 GHz	-2		dB
			f = 3 GHz	-2.4		
BW _{Dx}	Dx Differential -3-dB bandwidth	ZQE package		7		GHz
		RTQ package		5		
BW _{AUX}	AUX -3-dB bandwidth			720		MHz

(1) For Return Loss, Crosstalk, Off-Isolation, and Insertion Loss values the data was collected on a Rogers material board with minimum length traces on the input and output of the device under test.

7.7 Switching Characteristics

Under recommended operating conditions; R_{LOAD} , $R_{SC} = 50 \Omega$ (unless otherwise noted)

PARAMETER	TEST CONDITIONS	MIN	TYP	MAX	UNIT
t _{PD}	Switch propagation delay R_{SC} and $R_{LOAD} = 50 \Omega$, See Figure 2			200	ps
t _{on(OE_L-H)}	Time from OE toggling High and valid data at the outputs R_{SC} and $R_{LOAD} = 50 \Omega$, $V_{CM} = 3 V - 3.3 V$		1	2	μs
t _{off(OE_H-L)}	Time from OE toggling Low and outputs are in Z-state		15	50	
t _{SWITCH_OVER}	Time to switch between ports when DX_SEL or AUX_SEL state is changed for Data, AUX, DDC signals R_{SC} and $R_{LOAD} = 50 \Omega$, See Figure 1		0.7	1	μs
t _{on}	Dx_SEL/AUX_SEL-to-Switch t _{on} (HPD) $R_{LOAD} = 125k \Omega$, See Figure 1		0.7	1	μs
t _{off}	Dx_SEL/AUX_SEL-to-Switch t _{off} (HPD)		0.7	20	
t _{SK(O)}	Inter-Pair output skew (CH-CH) R_{SC} and $R_{LOAD} = 50 \Omega$, See Figure 2			30	ps
t _{SK(b-b)}	Intra-Pair output skew (bit-bit)		1	5	

7.8 Timing Diagrams

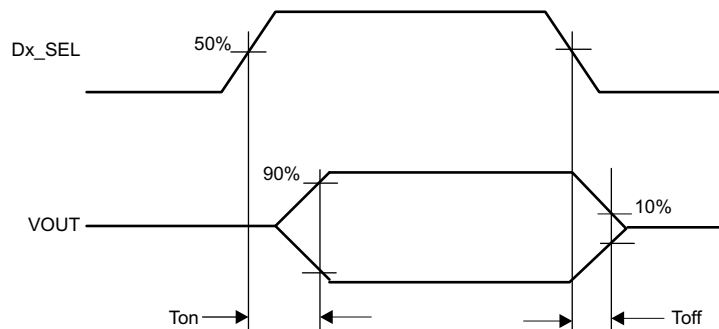
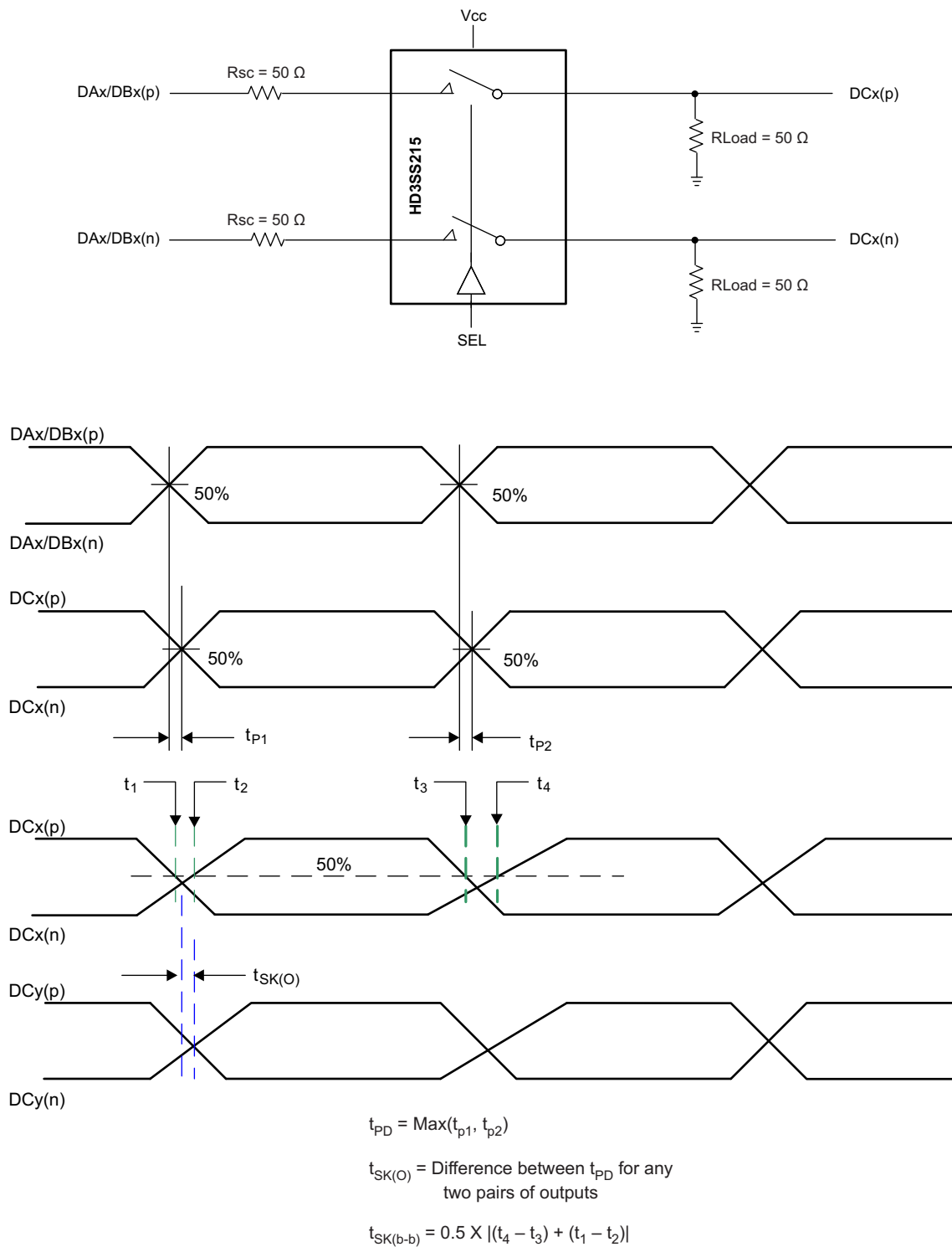

Figure 1. Select to Switch t_{on} and t_{off}

Timing Diagrams (continued)

Figure 2. Propagation Delay and Skew

8 Detailed Description

8.1 Overview

The HD3SS215 is a generic analog, differential passive switch that can work for any high speed interface applications, as long as it is biased at a common mode voltage range of 0 V to 3.3 V and has differential signaling with differential amplitude up to 1800 mV_{pp}. It employs adaptive tracking that maintains the high speed channel impedance over the entire common mode voltage range. In high-speed applications and data paths, signal integrity is an important concern. The switch offers excellent dynamic performance such as high isolation, crosstalk immunity, and minimal bit-bit skew. These characteristics allow the device to function seamlessly in the system without compromising signal integrity. The 2:1/1:2, mux/de-mux device operates with ports A or B switched to port C, or port C switched to either port A or B. This flexibility allows an application to select between one of two Sources on ports A and B and send the output to the sink on port C. Similarly, a Source on port C can select between one of two Sink devices on ports A and B to send the data. To comply with DisplayPort, DP++ and HDMI applications, the HD3SS215 also switches AUX, HPD, and DDC along with the high-speed differential signals. The HPD and data signals are both switched through the Dx_SEL pin. AUX and DDC are controlled with AUX_SEL and Dx_SEL. The Functional Modes section contains information on how to set the control pins.

With an OE control pin, the HD3SS215 is operational, with low active current, when this pin is high. When OE is pulled lowed, the device goes into standby mode and draws very little current in order to save power consumption in the application.

8.2 Functional Block Diagram

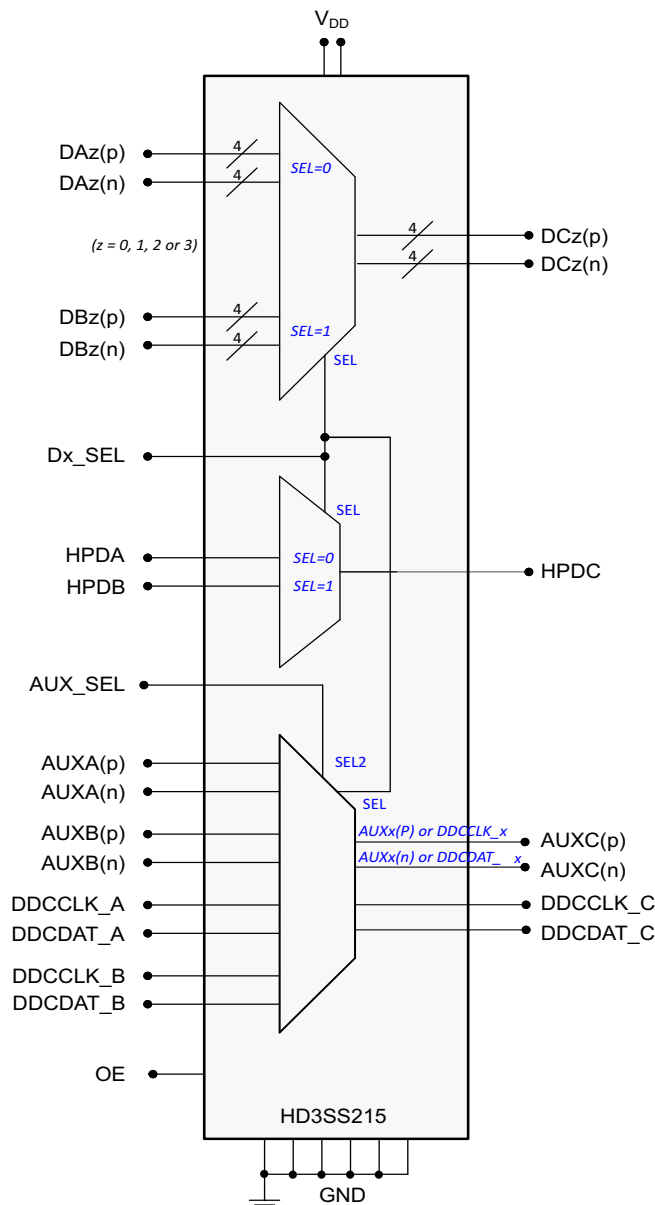

NOTE: The high speed data ports incorporate 20kΩ pull down resistors that are switched in when a port is not selected and switched out when the port is selected.

Figure 3. Functional Block Diagram

8.3 Feature Description

8.3.1 High Speed Switching

The HD3SS215 supports switching of 6 Gbps data rates. The wide common mode of the device enables it to support TMDS signal levels and DisplayPort signals. The high speed muxing is designed with a wide –3dB differential bandwidth of 7 GHz and industry leading dynamic characteristics. All of these attributes help maintain signal integrity in the application. Each high speed port incorporates 20kΩ pull down resistors that are switched in when the port is not selected and switched out when the port is selected.

8.3.2 HPD, AUX, and DDC Switching

HPD, AUX and DDC switching is supported through the HD3SS215. This enables the device to work in multiple application scenarios within multiple electrical standards. The AUXA/B and DDCA/B lines can both be switched to the AUXC port. This feature supports DP++ or AUX only adapters. For HDMI applications, the DDC channels are switched to the DDC_C port only and the AUX channel can remain active or the end user can make it float.

8.3.3 Output Enable and Power Savings

The HD3SS215 has two power modes, active/normal operating mode, and standby mode. During standby mode, the device consumes very little current to save the maximum power. To enter standby mode, the OE control pin is pulled low and must remain low. For active/normal operation, the OE control pin should be pulled high to VDD through a resistor.

8.4 Device Functional Modes

8.4.1 Switch Control Modes

Refer to the [Functional Block Diagram](#).

The HD3SS215 behaves as a two to one or one to two differential switch using high bandwidth pass gates. The input ports are selected using the AUX_SEL pin and Dx_SEL pin which are shown in [Table 1](#).

Table 1. Switch Control Logic⁽¹⁾⁽²⁾⁽³⁾

CONTROL LINES ⁽⁴⁾		SWITCHED I/O PINS								
AUX_SEL	Dx_SEL	DCz(p) Pin z = 0, 1, 2 or 3	DCz(n) Pin z = 0, 1, 2 or 3	HPDC Pin	AUXA	AUXB	AUXC	DDCA	DDCB	DDCC
L	L	DAz(p)	DAz(n)	HPDA	To/From AUXC	Z	To/From AUXA	Z	Z	Z
L	H	DBz(p)	DBz(n)	HPDB	Z	To/From AUXC	To/From AUXB	Z	Z	Z
H	L	DAz(p)	DAz(n)	HPDA	Z	Z	To/From DDCA	To/From AUXC	Z	Z
H	H	DBz(p)	DBz(n)	HPDB	Z	Z	To/From DDCB	Z	To/From AUXC	Z
M ⁽⁴⁾	L	DAz(p)	DAz(n)	HPDA	To/From AUXC	Z	To/From AUXA	To/From DDCC	Z	To/From DDCA
M ⁽⁴⁾	H	DBz(p)	DBz(n)	HPDB	Z	To/From AUXC	To/From AUXB	Z	To/From DDCC	To/From DDCB

(1) Z = High Impedance

(2) OE pin - For normal operation, drive OE high. Driving the OE pin low will disable the switch.

(3) The ports which are not selected by the control lines will be in high impedance status.

(4) For HDMI application, keep the AUX_SEL at middle level voltage. The AUX channel is still active, and the end user can make the lines float.

9 Applications and Implementation

NOTE

Information in the following applications sections is not part of the TI component specification, and TI does not warrant its accuracy or completeness. TI's customers are responsible for determining suitability of components for their purposes. Customers should validate and test their design implementation to confirm system functionality.

9.1 Application Information

The HD3SS215 can be used in a variety of applications. This section shows the typical applications for DisplayPort, DP++, and HDMI. The example diagrams illustrate using the HD3SS215 in a two source to one sink application and a one source to two sinks application. All schematics are using the ZQE pin-out.

9.2 Typical Applications

9.2.1 DisplayPort and Dual Mode Adapter with Two Sources

The application schematic below shows the HD3SS215 in the 2:1 configuration for DisplayPort switching. The HD3SS215 receives inputs from DP Source A and DP Source B. The control pins of the device can be set to select Source A/B inputs and transfer them to port C through the Dx_SEL control pin. The schematic also shows the CONFIG1 and AUX_SEL settings to configure the HD3SS215 to work with DP++ Type 2 and Type1 adapters. For this specific schematic, the AC capacitors needed on the MainLink signal lines are shown on the Sink side of the HD3SS215. This is done to decrease the BOM. If desired the AC capacitors maybe placed in the signal path on the Source A/B side of HD3SS215. Additional diagrams are provided to show the configuration of the AUX channel for 2:1 and 1:2 DisplayPort only applications.

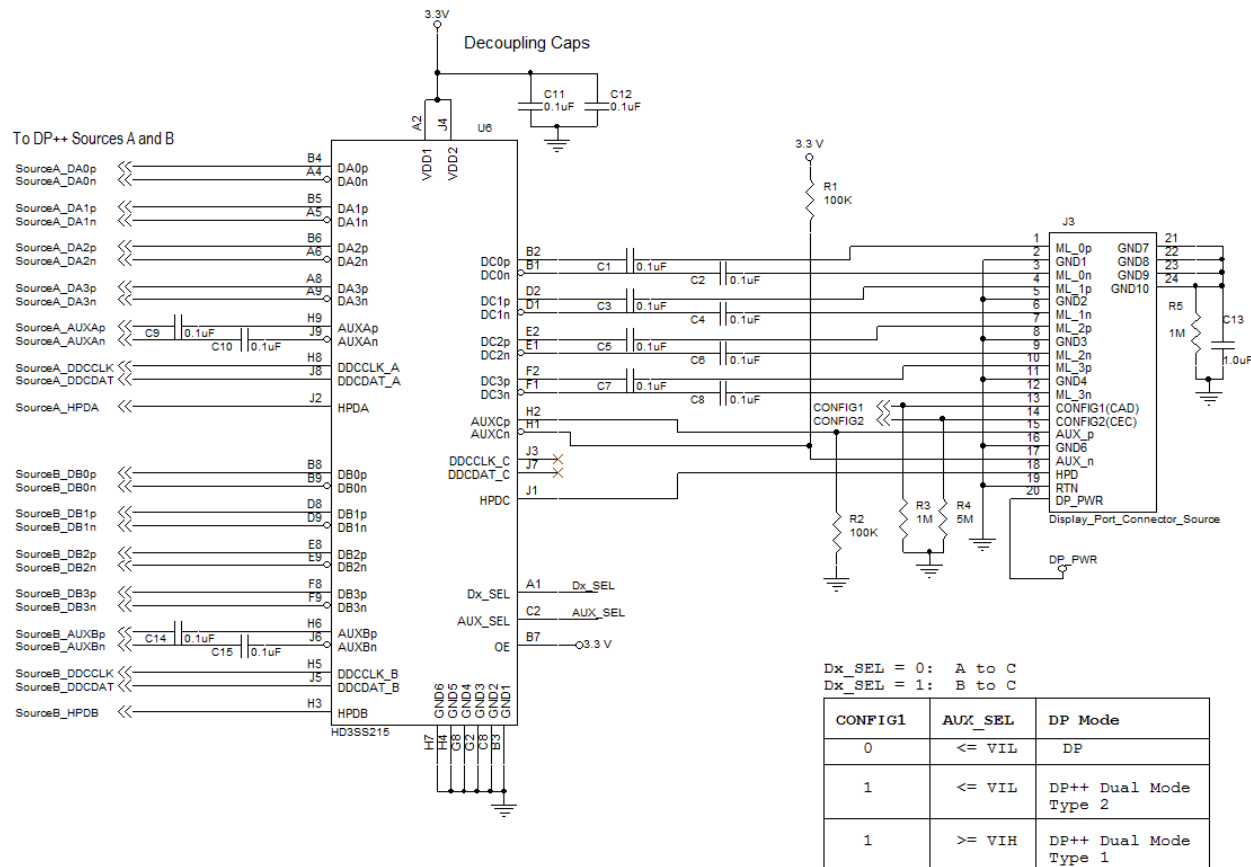

Figure 4. HD3SS215 Application Diagram for DisplayPort or Dual Mode Adapter Configuration

Typical Applications (continued)

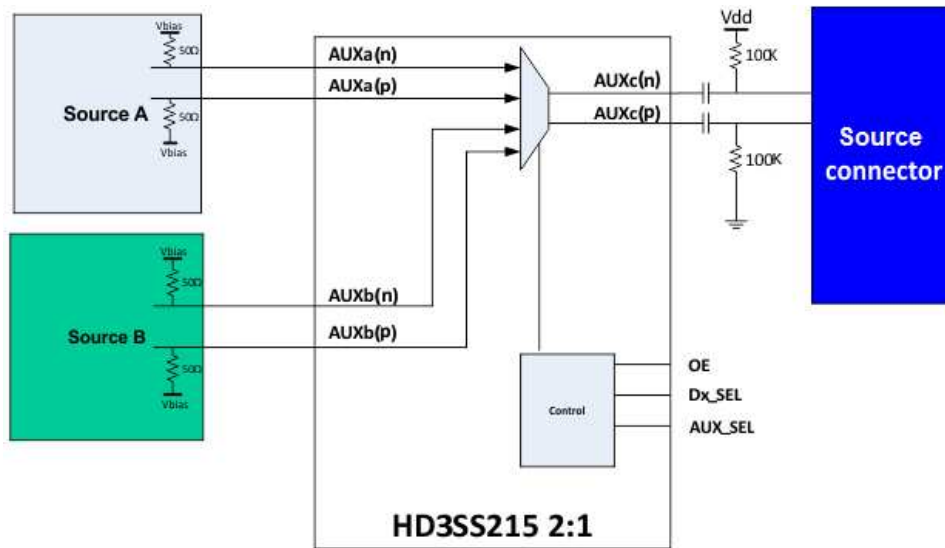

Figure 5. HD3SS215 AUX Channel in 2:1 DisplayPort Application

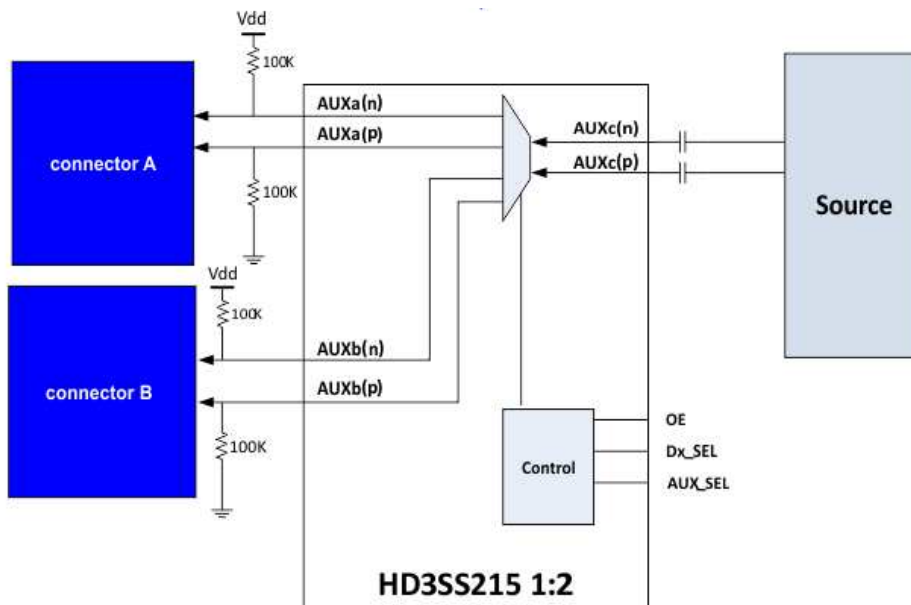

Figure 6. HD3SS215 AUX Channel in 1:2 DisplayPort Application

Typical Applications (continued)

9.2.1.1 Design Requirements

Table 2. Design Parameters

DESIGN PARAMETER	EXAMPLE VALUE
VDD	3.3 V
Decoupling Capacitors	0.1 μ F
AC Capacitors	75 nF to 200 nF (100 nF shown)
AUX Pull-Up/Pull-Down Resistors	10 k Ω to 105 k Ω (100 k Ω shown)
Pull-Up/Pull-Down Resistors for Control Pins	10 k Ω
CONFIG1/CONFIG2 Pull-Down Resistors	1 M Ω and 5 M Ω

9.2.1.2 Detailed Design Procedure

The HD3SS215 is designed to operate with a 3.3 V power supply. Levels above those listed in the Absolute Ratings table should not be used. If using a higher voltage system power supply, a voltage regulator can be used to step down to 3.3 V. Decoupling capacitors may be used to reduce noise and improve power supply integrity. AC capacitors must be placed on the MainLink lines. Additionally, AC capacitors are placed on the AUXC lines. After the blocking capacitors, the AUXCp line must be pulled down weakly through a resistor to ground, and the AUXCn line must be pulled up weakly through a resistor to VDD. The voltage level of the control pins, AUX_SEL and Dx_SEL should be set according to the application and muxing desired. For a DisplayPort connector, the CONFIG1 and CONFIG2 pins should be pulled to ground through resistors. For Dual Mode adapter implementation, the CONFIG1 line may be used to perform cable adapter detection. The CONFIG2 line can be configured for an HDMI adaptor or left as a no connect for a DVI adapter. The CONFIG2 pin on the connector should be pulled up or left floating accordingly for Dual Mode adapter configuration.

9.2.2 HDMI Application with Two Sinks

The HD3SS215 can be placed in applications needing to switch between two sinks. In this example, the HDMI source selects between Sink A or Sink B in the 1:2 configuration.

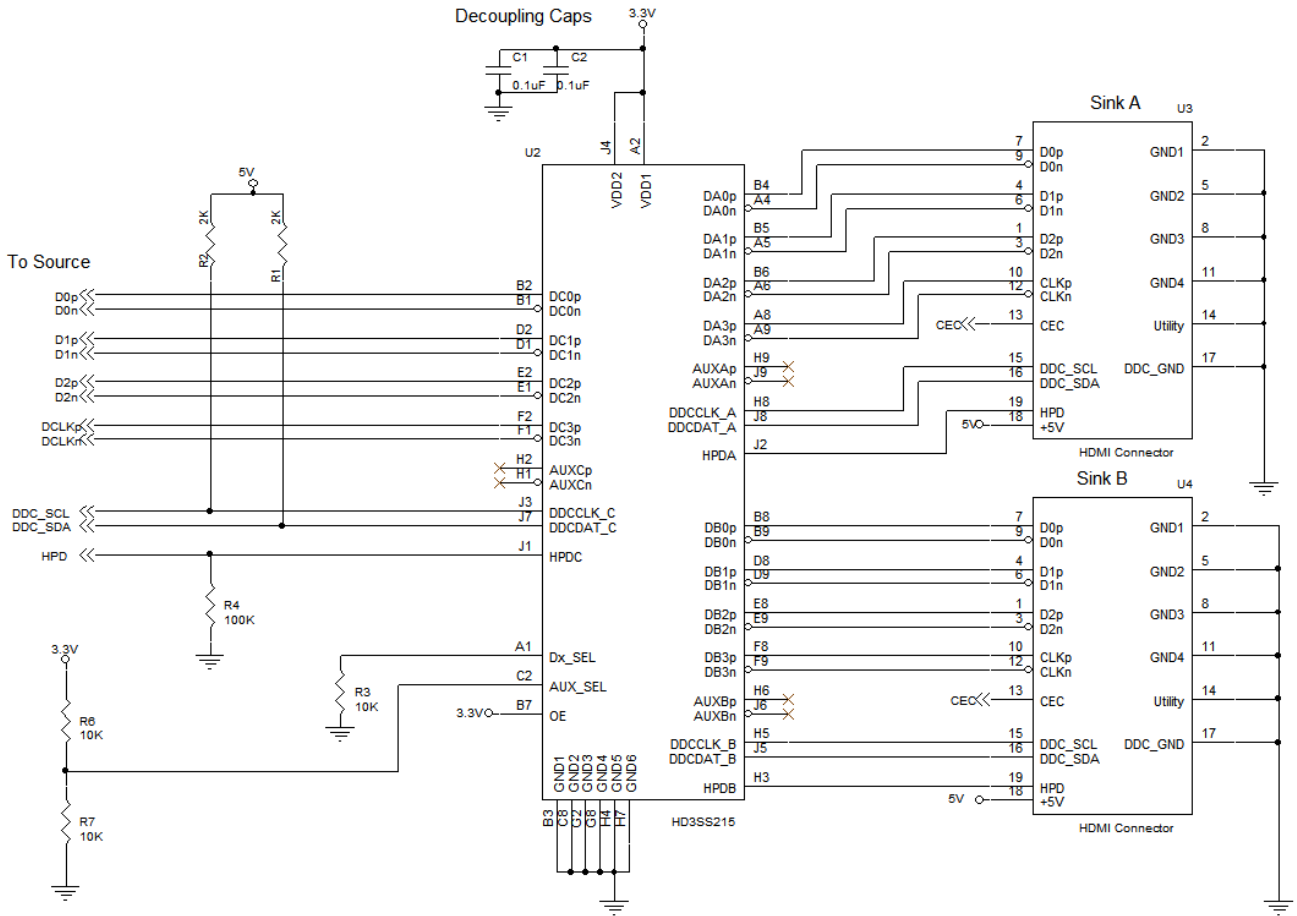

Control for AUX_SEL and Dx_SEL. Setup to select Sink A shown.

Figure 7. Application Diagram for a 1:2 Configuration with HDMI Source and Connectors

9.2.2.1 Design Requirements

Table 3. Design Parameters

DESIGN PARAMETER	EXAMPLE VALUE
VDD	3.3 V
Decoupling Capacitors	0.1 μ F
DDC Pull-Up Resistors	1.5 k Ω to 2 k Ω to 5 V (2 k Ω shown)
Pull-Up/Pull-Down Resistors for Control Pins	10 k Ω
HPD Pull-Down Resistor	100 k Ω

9.2.2.2 Detailed Design Procedure

The HD3SS215 is designed to operate with a 3.3 V power supply. Levels above those listed in the Absolute Ratings table should not be used. If using a higher voltage system power supply, a voltage regulator can be used to step down to 3.3 V. Decoupling capacitors may be used to reduce power noise and improve power supply integrity. Pull-up resistors to 5 V must be placed on the source side DDC clock and data lines according to the HDMI2.0 Standard. A weak pull down resistor should be placed on the source side HPD line. This is to ensure the source can differentiate between when HPD is disconnected or at a high voltage level. The AUX_SEL and Dx_SEL control pins should be set according to the application and desired muxing.

9.2.3 HDMI 2:1 Sink Application Using the RTQ Package

The HD3SS215 can be placed in applications needing to switch between two HDMI connectors and one Generic HDMI sink.

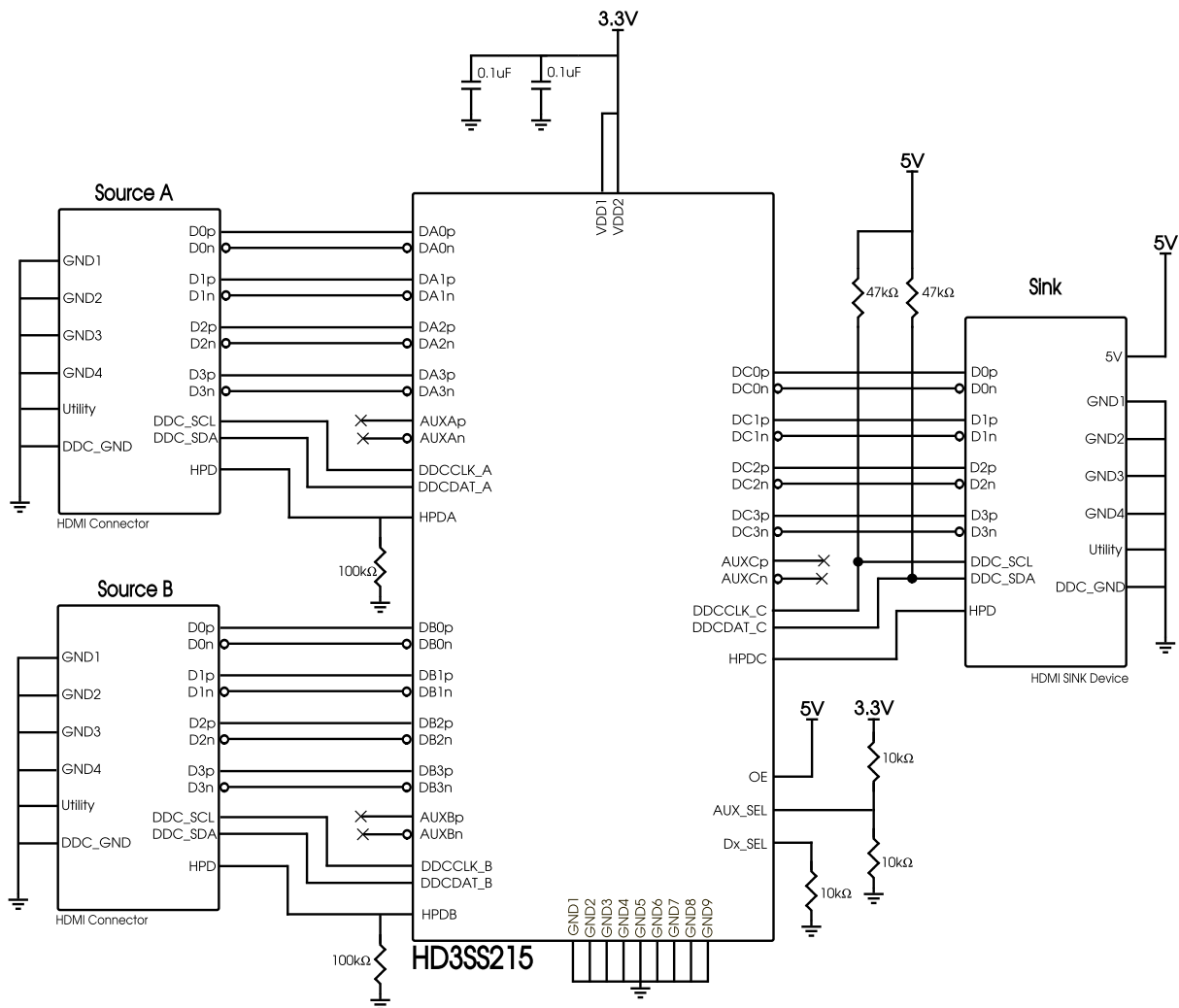

AUX_SEL and Dx_SEL configured for A to C

Figure 8. HDMI 2:1 Sink Application Using the RTQ Package

NOTE

According to the HDMI specification the DDC 2-kΩ pullup resistors can be replaced by 47-kΩ pullups. [Figure 8](#) schematic and [Figure 11](#) PCB layout example shows 47-kΩ pullup resistors.

10 Power Supply Recommendations

The HD3SS215 is designed to operate with a 3.3-V power supply. Levels above those listed in the Absolute Ratings table should not be used. If using a higher voltage system power supply, a voltage regulator can be used to step down to 3.3 V. Decoupling capacitors must be used to reduce power supply noise.

11 Layout

11.1 Layout Guidelines

- The ESD and EMI protection devices (if used) should be placed as close as possible to the connector.
- Place voltage regulators as far away as possible from the high-speed differential pairs.
- It is recommended that small decoupling capacitors for the HD3SS215 power rail be placed close to the device.
- The high-speed differential signal traces should be routed on the top layer to avoid the use of vias and allow clean interconnects to the mux.
- The high speed differential signal traces should be routed parallel to each other as much as possible. It is recommended the traces be symmetrical.
- In order to control impedance for transmission lines, a solid ground plane should be placed next to the high-speed signal layer. This also provides an excellent low-inductance path for the return current flow.
- The power plane should be placed next to the ground plane to create additional high-frequency bypass capacitance.
- Adding test points will cause impedance discontinuity and will therefore negatively impact signal performance. If test points are used, they should be placed in series and symmetrically. They must not be placed in a manner that causes stubs on the differential pair.
- Avoid 90 degree turns in traces. The use of bends in differential traces should be kept to a minimum. When bends are used, the number of left and right bends should be as equal as possible and the angle of the bend should be ≥ 135 degrees. This will minimize any length mismatch caused by the bends and therefore minimize the impact bends have on EMI.

11.2 Layout Example

An example layout for the HD3SS215 shows the device implemented on a 4-layer board. The layout figures follow the DisplayPort application schematic above. The top layer layout view shows the signal routing for two sources and one sink. The bottom layer layout view shows the remaining signal routing and a copper pour implemented for the decoupling capacitors.

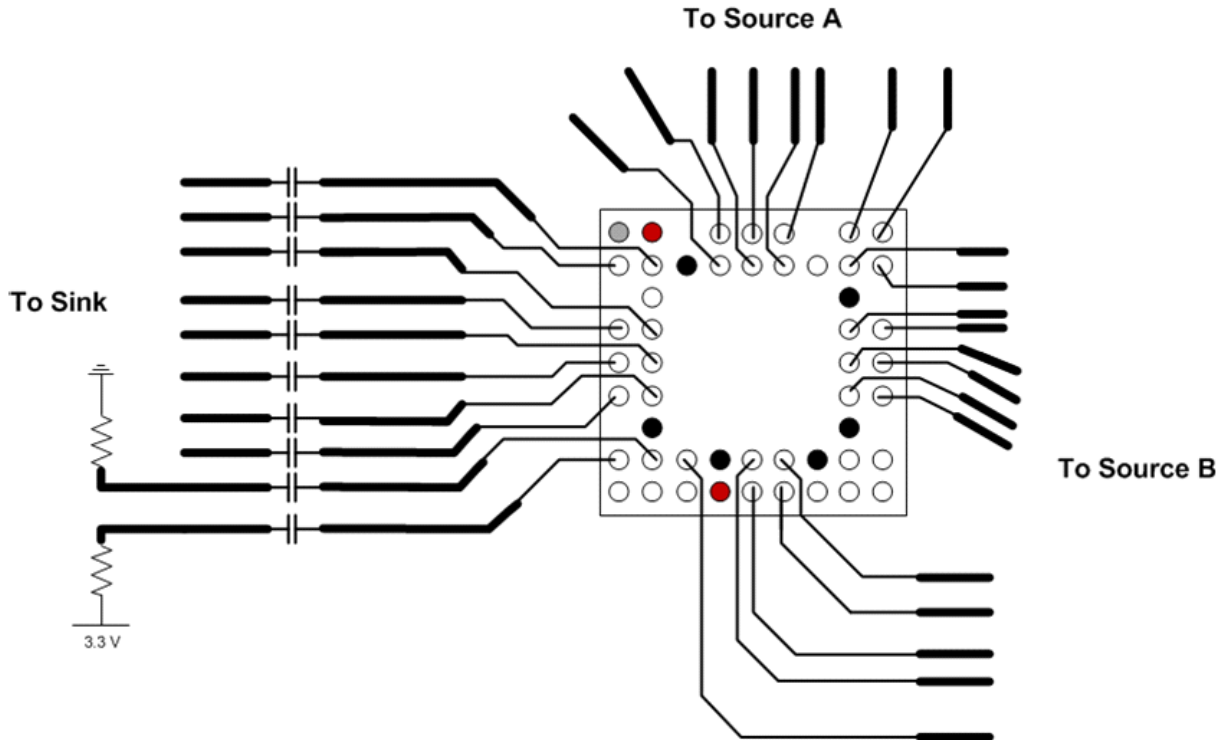

Figure 9. Top Layer Layout View

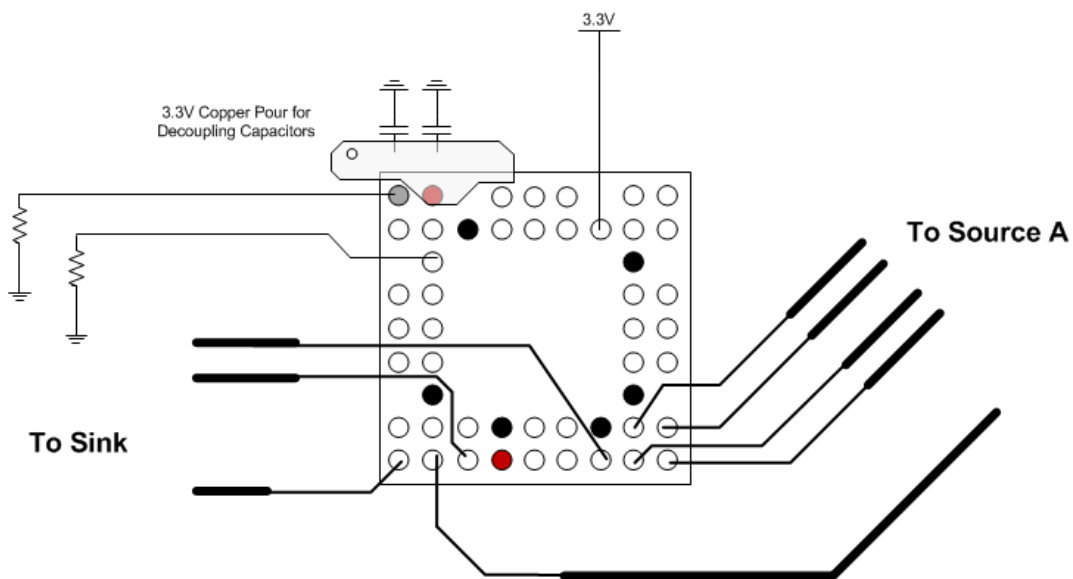

Figure 10. Bottom Layer Layout View

Layout Example (continued)

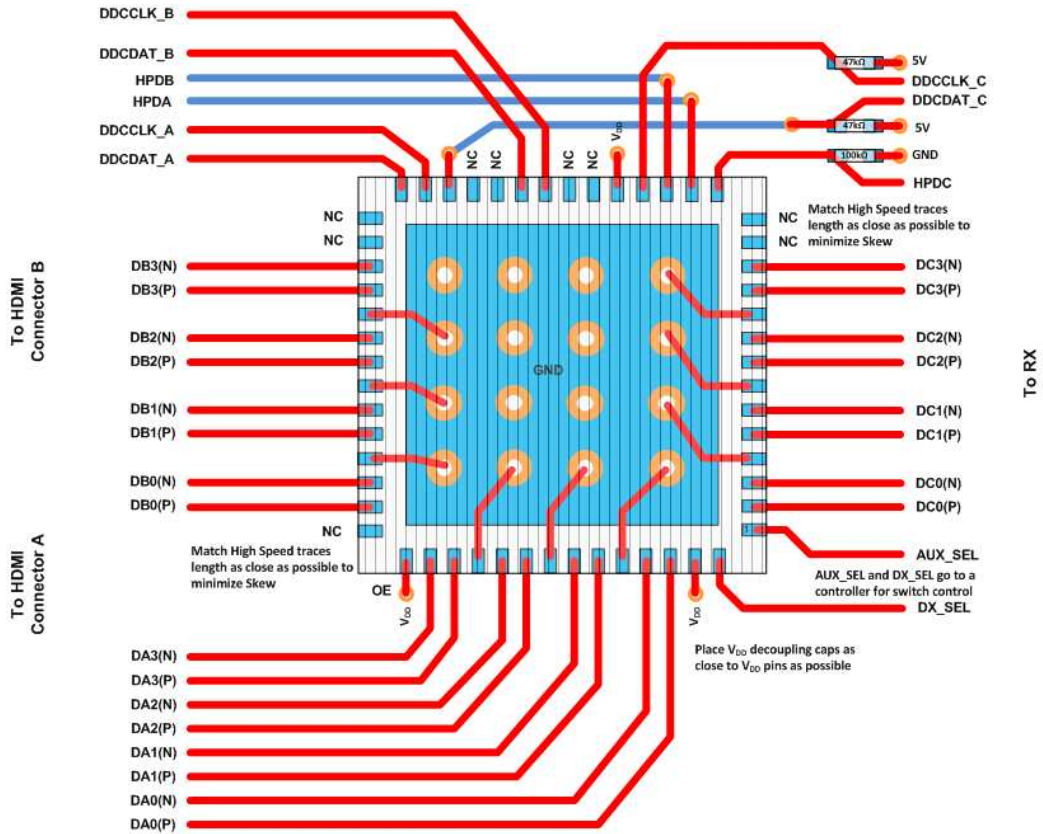

Figure 11. RTQ Layout for 2:1 HDMI Sink Application

12 Device and Documentation Support

12.1 Community Resources

The following links connect to TI community resources. Linked contents are provided "AS IS" by the respective contributors. They do not constitute TI specifications and do not necessarily reflect TI's views; see TI's [Terms of Use](#).

TI E2E™ Online Community *TI's Engineer-to-Engineer (E2E) Community*. Created to foster collaboration among engineers. At e2e.ti.com, you can ask questions, share knowledge, explore ideas and help solve problems with fellow engineers.

Design Support *TI's Design Support* Quickly find helpful E2E forums along with design support tools and contact information for technical support.

12.2 Trademarks

E2E is a trademark of Texas Instruments.

All trademarks are the property of their respective owners.

12.3 Electrostatic Discharge Caution



These devices have limited built-in ESD protection. The leads should be shorted together or the device placed in conductive foam during storage or handling to prevent electrostatic damage to the MOS gates.

12.4 Glossary

[SLYZ022](#) — *TI Glossary*.

This glossary lists and explains terms, acronyms, and definitions.

13 Mechanical, Packaging, and Orderable Information

The following pages include mechanical packaging and orderable information. This information is the most current data available for the designated devices. This data is subject to change without notice and revision of this document. For browser-based versions of this data sheet, refer to the left-hand navigation.

PACKAGING INFORMATION

Orderable Device	Status (1)	Package Type	Package Drawing	Pins	Package Qty	Eco Plan (2)	Lead/Ball Finish (6)	MSL Peak Temp (3)	Op Temp (°C)	Device Marking (4/5)	Samples
HD3SS215IRTQR	ACTIVE	QFN	RTQ	56	2000	Green (RoHS & no Sb/Br)	CU NIPDAU	Level-3-260C-168 HR	-40 to 85	HD3SS215I	Samples
HD3SS215IRTQT	ACTIVE	QFN	RTQ	56	250	Green (RoHS & no Sb/Br)	CU NIPDAU	Level-3-260C-168 HR	-40 to 85	HD3SS215I	Samples
HD3SS215IZQER	ACTIVE	BGA MICROSTAR JUNIOR	ZQE	50	2500	Green (RoHS & no Sb/Br)	SNAGCU	Level-3-260C-168 HR	-40 to 85	HD3SS215I	Samples
HD3SS215IZQET	ACTIVE	BGA MICROSTAR JUNIOR	ZQE	50	250	Green (RoHS & no Sb/Br)	SNAGCU	Level-3-260C-168 HR	-40 to 85	HD3SS215I	Samples
HD3SS215RTQR	ACTIVE	QFN	RTQ	56	2000	Green (RoHS & no Sb/Br)	CU NIPDAU	Level-3-260C-168 HR	0 to 70	HD3SS215	Samples
HD3SS215RTQT	ACTIVE	QFN	RTQ	56	250	Green (RoHS & no Sb/Br)	CU NIPDAU	Level-3-260C-168 HR	0 to 70	HD3SS215	Samples
HD3SS215ZQER	ACTIVE	BGA MICROSTAR JUNIOR	ZQE	50	2500	Green (RoHS & no Sb/Br)	SNAGCU	Level-3-260C-168 HR	0 to 70	HD3SS215	Samples
HD3SS215ZQET	PREVIEW	BGA MICROSTAR JUNIOR	ZQE	50	250	TBD	Call TI	Call TI	0 to 70	HD3SS215	

(1) The marketing status values are defined as follows:

ACTIVE: Product device recommended for new designs.

LIFEBUY: TI has announced that the device will be discontinued, and a lifetime-buy period is in effect.

NRND: Not recommended for new designs. Device is in production to support existing customers, but TI does not recommend using this part in a new design.

PREVIEW: Device has been announced but is not in production. Samples may or may not be available.

OBSELETE: TI has discontinued the production of the device.

(2) Eco Plan - The planned eco-friendly classification: Pb-Free (RoHS), Pb-Free (RoHS Exempt), or Green (RoHS & no Sb/Br) - please check <http://www.ti.com/productcontent> for the latest availability information and additional product content details.

TBD: The Pb-Free/Green conversion plan has not been defined.

Pb-Free (RoHS): TI's terms "Lead-Free" or "Pb-Free" mean semiconductor products that are compatible with the current RoHS requirements for all 6 substances, including the requirement that lead not exceed 0.1% by weight in homogeneous materials. Where designed to be soldered at high temperatures, TI Pb-Free products are suitable for use in specified lead-free processes.

Pb-Free (RoHS Exempt): This component has a RoHS exemption for either 1) lead-based flip-chip solder bumps used between the die and package, or 2) lead-based die adhesive used between the die and leadframe. The component is otherwise considered Pb-Free (RoHS compatible) as defined above.

Green (RoHS & no Sb/Br): TI defines "Green" to mean Pb-Free (RoHS compatible), and free of Bromine (Br) and Antimony (Sb) based flame retardants (Br or Sb do not exceed 0.1% by weight in homogeneous material)

- (3) MSL, Peak Temp. - The Moisture Sensitivity Level rating according to the JEDEC industry standard classifications, and peak solder temperature.
- (4) There may be additional marking, which relates to the logo, the lot trace code information, or the environmental category on the device.
- (5) Multiple Device Markings will be inside parentheses. Only one Device Marking contained in parentheses and separated by a "~" will appear on a device. If a line is indented then it is a continuation of the previous line and the two combined represent the entire Device Marking for that device.
- (6) Lead/Ball Finish - Orderable Devices may have multiple material finish options. Finish options are separated by a vertical ruled line. Lead/Ball Finish values may wrap to two lines if the finish value exceeds the maximum column width.

Important Information and Disclaimer:The information provided on this page represents TI's knowledge and belief as of the date that it is provided. TI bases its knowledge and belief on information provided by third parties, and makes no representation or warranty as to the accuracy of such information. Efforts are underway to better integrate information from third parties. TI has taken and continues to take reasonable steps to provide representative and accurate information but may not have conducted destructive testing or chemical analysis on incoming materials and chemicals. TI and TI suppliers consider certain information to be proprietary, and thus CAS numbers and other limited information may not be available for release.

In no event shall TI's liability arising out of such information exceed the total purchase price of the TI part(s) at issue in this document sold by TI to Customer on an annual basis.

TAPE AND REEL INFORMATION



QUADRANT ASSIGNMENTS FOR PIN 1 ORIENTATION IN TAPE



*All dimensions are nominal

Device	Package Type	Package Drawing	Pins	SPQ	Reel Diameter (mm)	Reel Width W1 (mm)	A0 (mm)	B0 (mm)	K0 (mm)	P1 (mm)	W (mm)	Pin1 Quadrant
HD3SS215IRTQR	QFN	RTQ	56	2000	330.0	16.4	8.3	8.3	1.1	12.0	16.0	Q2
HD3SS215IRTQT	QFN	RTQ	56	250	180.0	16.4	8.3	8.3	1.1	12.0	16.0	Q2
HD3SS215IZQER	BGA MICROSTAR JUNIOR	ZQE	50	2500	330.0	12.4	5.3	5.3	1.5	8.0	12.0	Q1
HD3SS215IZQET	BGA MICROSTAR JUNIOR	ZQE	50	250	330.0	12.4	5.3	5.3	1.5	8.0	12.0	Q1
HD3SS215RTQR	QFN	RTQ	56	2000	330.0	16.4	8.3	8.3	1.1	12.0	16.0	Q2
HD3SS215RTQT	QFN	RTQ	56	250	180.0	16.4	8.3	8.3	1.1	12.0	16.0	Q2
HD3SS215ZQER	BGA MICROSTAR JUNIOR	ZQE	50	2500	330.0	12.4	5.3	5.3	1.5	8.0	12.0	Q1

TAPE AND REEL BOX DIMENSIONS

*All dimensions are nominal

Device	Package Type	Package Drawing	Pins	SPQ	Length (mm)	Width (mm)	Height (mm)
HD3SS215IRTQR	QFN	RTQ	56	2000	367.0	367.0	38.0
HD3SS215IRTQT	QFN	RTQ	56	250	210.0	185.0	35.0
HD3SS215IZQER	BGA MICROSTAR JUNIOR	ZQE	50	2500	336.6	336.6	31.8
HD3SS215IZQET	BGA MICROSTAR JUNIOR	ZQE	50	250	336.6	336.6	31.8
HD3SS215RTQR	QFN	RTQ	56	2000	367.0	367.0	38.0
HD3SS215RTQT	QFN	RTQ	56	250	210.0	185.0	35.0
HD3SS215ZQER	BGA MICROSTAR JUNIOR	ZQE	50	2500	336.6	336.6	31.8

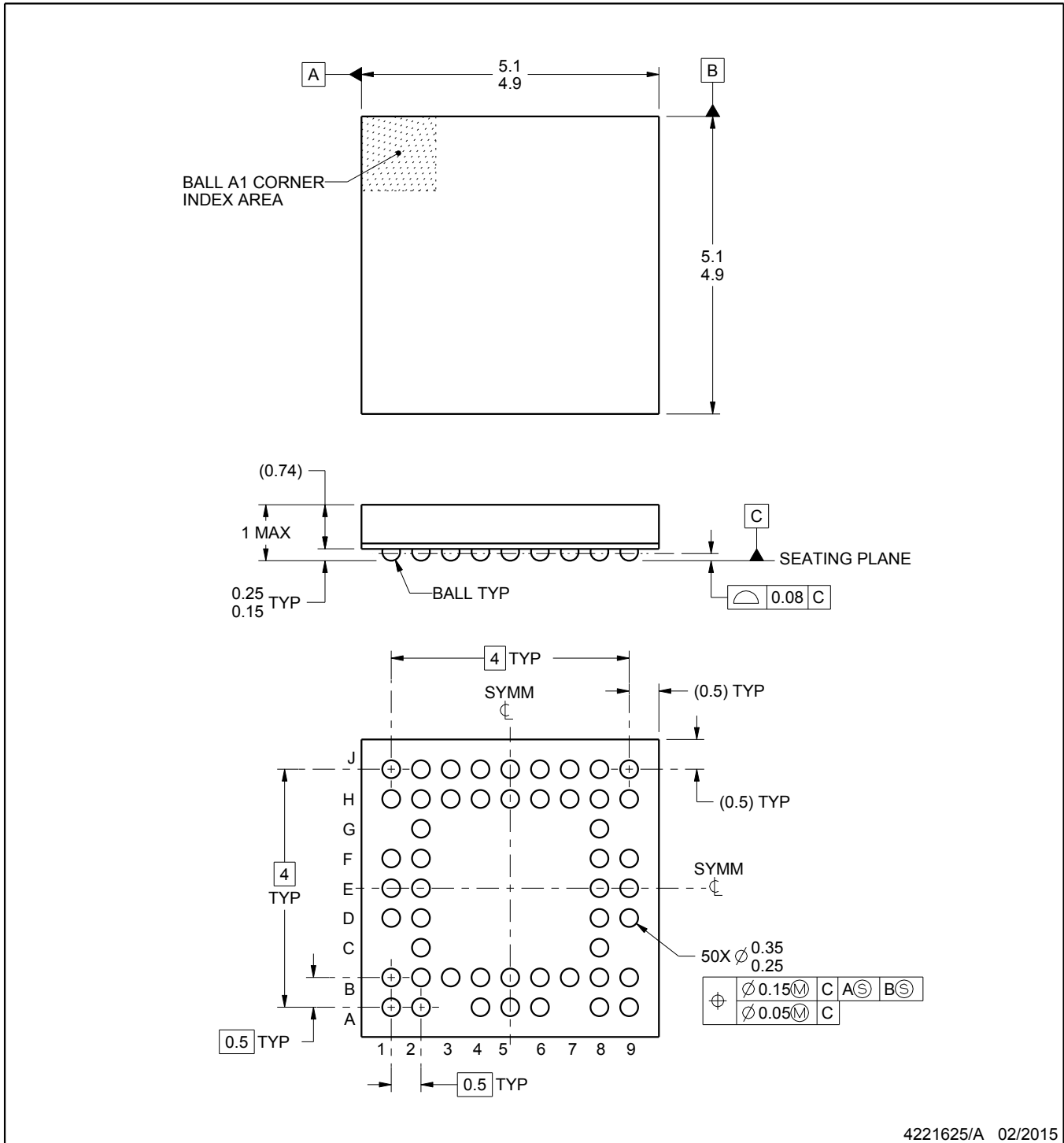

4221625/A 02/2015

MicroStar Junior is trademark of Texas Instruments.

NOTES:

1. All linear dimensions are in millimeters. Any dimensions in parenthesis are for reference only. Dimensioning and tolerancing per ASME Y14.5M.
2. This drawing is subject to change without notice.
3. Reference JEDEC registration MO-225.

EXAMPLE BOARD LAYOUT

ZQE0050A

BGA MicroStar Jr™ - 1 mm max height

PLASTIC BALL GRID ARRAY

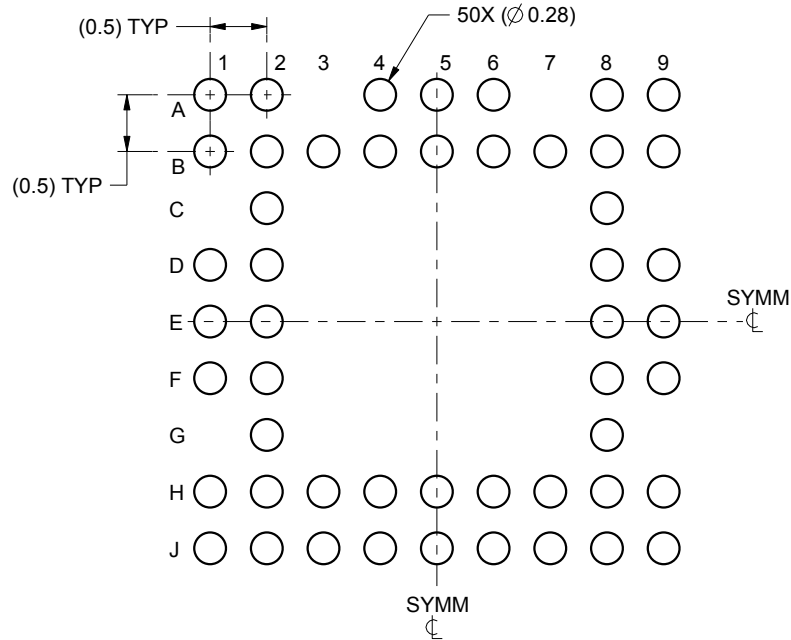

LAND PATTERN EXAMPLE
SCALE:15X

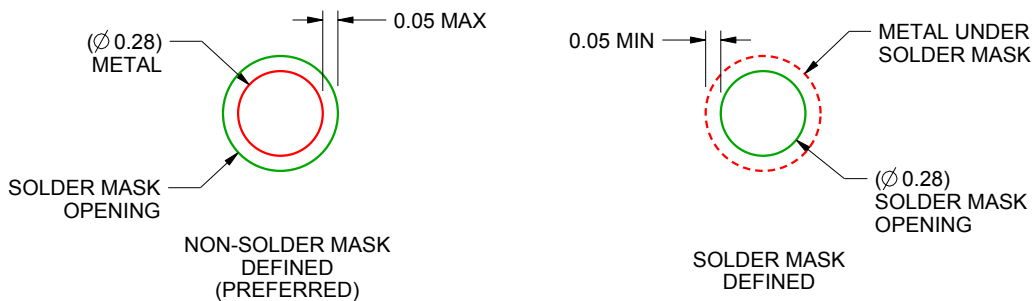

SOLDER MASK DETAILS
NOT TO SCALE

4221625/A 02/2015

NOTES: (continued)

- Final dimensions may vary due to manufacturing tolerance considerations and also routing constraints. For information, see Texas Instruments literature number SSYZ015 (www.ti.com/lit/ssyz015).

EXAMPLE STENCIL DESIGN

ZQE0050A

BGA MicroStar Jr™ - 1 mm max height

PLASTIC BALL GRID ARRAY

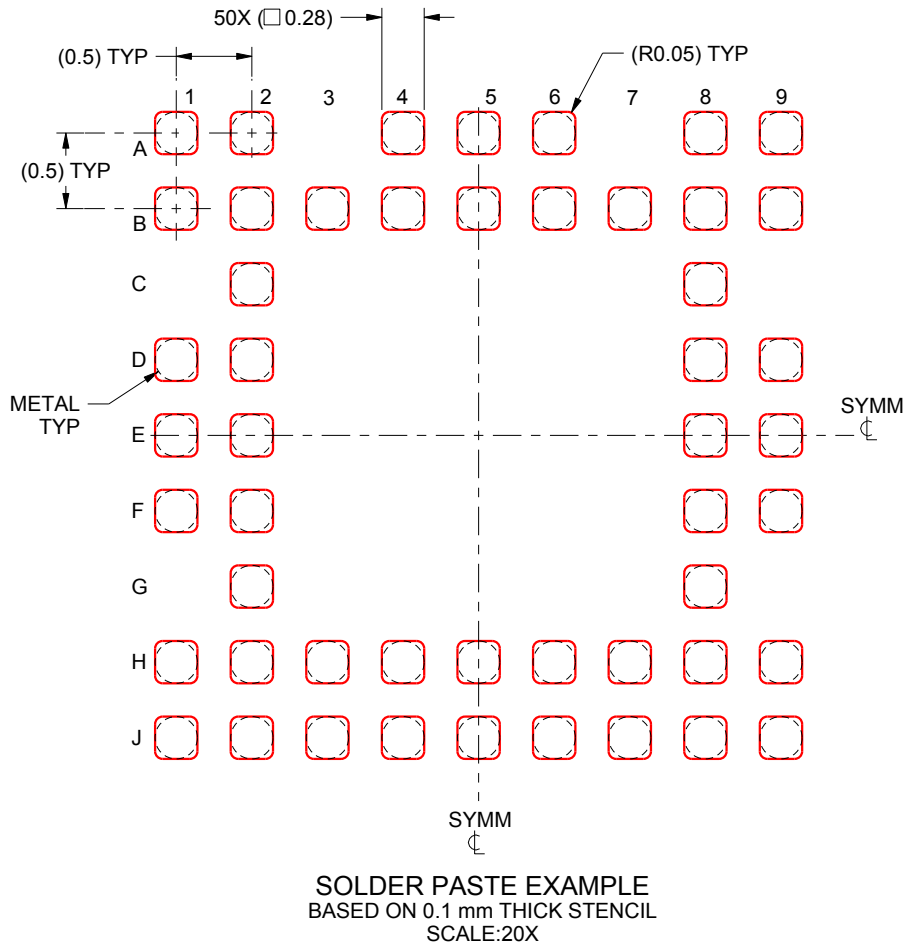

4221625/A 02/2015

NOTES: (continued)

5. Laser cutting apertures with trapezoidal walls and rounded corners may offer better paste release.

RTQ (S-PVQFN-N56)

PLASTIC QUAD FLATPACK NO-LEAD

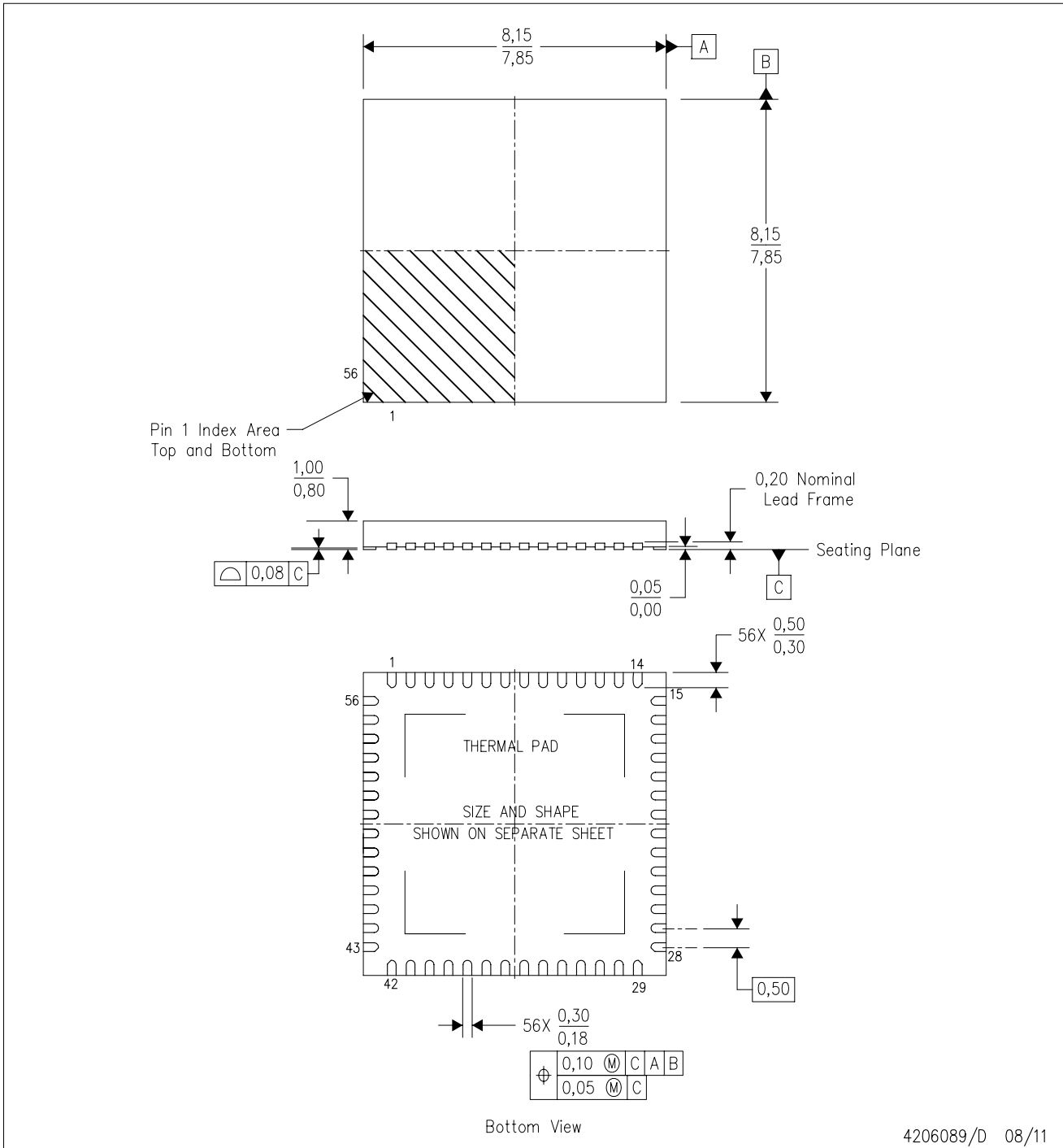

- NOTES:
- A. All linear dimensions are in millimeters. Dimensioning and tolerancing per ASME Y14.5-1994.
 - B. This drawing is subject to change without notice.
 - C. QFN (Quad Flatpack No-Lead) Package configuration.
 - D. The package thermal pad must be soldered to the board for thermal and mechanical performance.
 - E. See the additional figure in the Product Data Sheet for details regarding the exposed thermal pad features and dimensions.
 - F. Package complies to JEDEC MO-220.

RTQ (S-PVQFN-N56)

PLASTIC QUAD FLATPACK NO-LEAD

THERMAL INFORMATION

This package incorporates an exposed thermal pad that is designed to be attached directly to an external heatsink. The thermal pad must be soldered directly to the printed circuit board (PCB). After soldering, the PCB can be used as a heatsink. In addition, through the use of thermal vias, the thermal pad can be attached directly to the appropriate copper plane shown in the electrical schematic for the device, or alternatively, can be attached to a special heatsink structure designed into the PCB. This design optimizes the heat transfer from the integrated circuit (IC).

For information on the Quad Flatpack No-Lead (QFN) package and its advantages, refer to Application Report, QFN/SON PCB Attachment, Texas Instruments Literature No. SLUA271. This document is available at www.ti.com.

The exposed thermal pad dimensions for this package are shown in the following illustration.

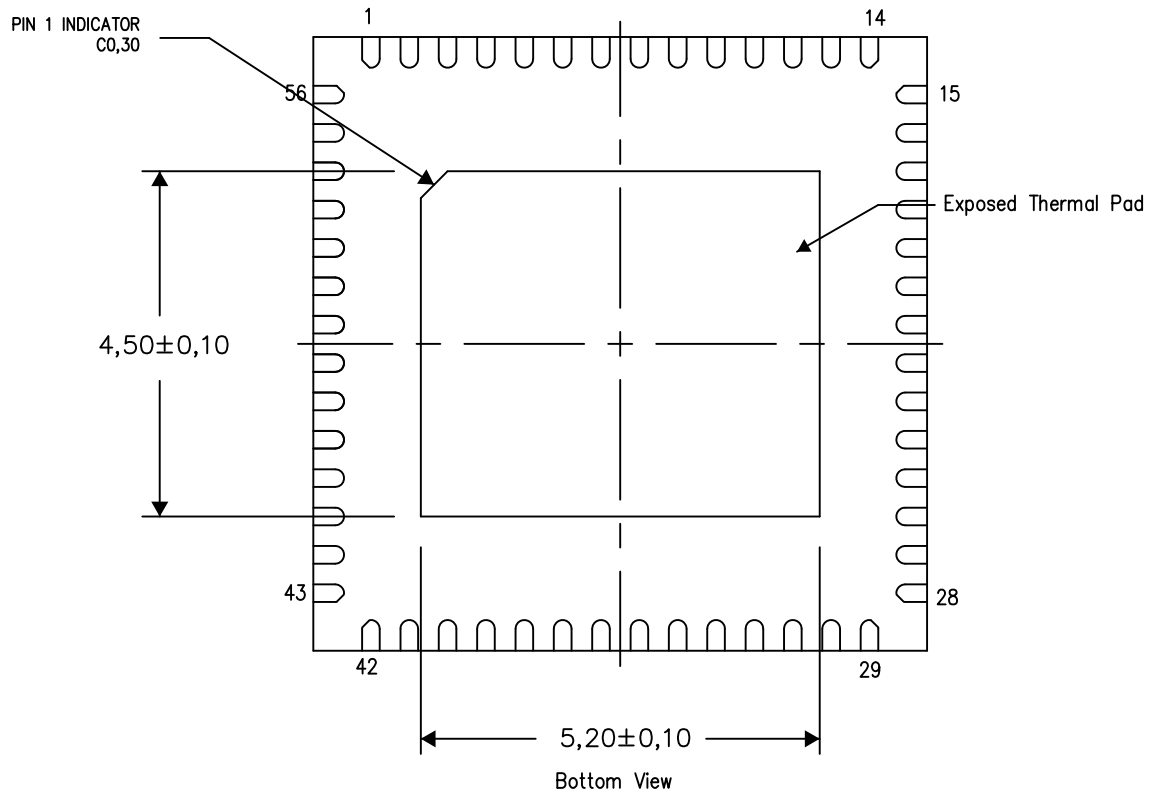

Exposed Thermal Pad Dimensions

4206252-2/Q 03/15

NOTE: All linear dimensions are in millimeters

IMPORTANT NOTICE

Texas Instruments Incorporated and its subsidiaries (TI) reserve the right to make corrections, enhancements, improvements and other changes to its semiconductor products and services per JESD46, latest issue, and to discontinue any product or service per JESD48, latest issue. Buyers should obtain the latest relevant information before placing orders and should verify that such information is current and complete. All semiconductor products (also referred to herein as "components") are sold subject to TI's terms and conditions of sale supplied at the time of order acknowledgment.

TI warrants performance of its components to the specifications applicable at the time of sale, in accordance with the warranty in TI's terms and conditions of sale of semiconductor products. Testing and other quality control techniques are used to the extent TI deems necessary to support this warranty. Except where mandated by applicable law, testing of all parameters of each component is not necessarily performed.

TI assumes no liability for applications assistance or the design of Buyers' products. Buyers are responsible for their products and applications using TI components. To minimize the risks associated with Buyers' products and applications, Buyers should provide adequate design and operating safeguards.

TI does not warrant or represent that any license, either express or implied, is granted under any patent right, copyright, mask work right, or other intellectual property right relating to any combination, machine, or process in which TI components or services are used. Information published by TI regarding third-party products or services does not constitute a license to use such products or services or a warranty or endorsement thereof. Use of such information may require a license from a third party under the patents or other intellectual property of the third party, or a license from TI under the patents or other intellectual property of TI.

Reproduction of significant portions of TI information in TI data books or data sheets is permissible only if reproduction is without alteration and is accompanied by all associated warranties, conditions, limitations, and notices. TI is not responsible or liable for such altered documentation. Information of third parties may be subject to additional restrictions.

Resale of TI components or services with statements different from or beyond the parameters stated by TI for that component or service voids all express and any implied warranties for the associated TI component or service and is an unfair and deceptive business practice. TI is not responsible or liable for any such statements.

Buyer acknowledges and agrees that it is solely responsible for compliance with all legal, regulatory and safety-related requirements concerning its products, and any use of TI components in its applications, notwithstanding any applications-related information or support that may be provided by TI. Buyer represents and agrees that it has all the necessary expertise to create and implement safeguards which anticipate dangerous consequences of failures, monitor failures and their consequences, lessen the likelihood of failures that might cause harm and take appropriate remedial actions. Buyer will fully indemnify TI and its representatives against any damages arising out of the use of any TI components in safety-critical applications.

In some cases, TI components may be promoted specifically to facilitate safety-related applications. With such components, TI's goal is to help enable customers to design and create their own end-product solutions that meet applicable functional safety standards and requirements. Nonetheless, such components are subject to these terms.

No TI components are authorized for use in FDA Class III (or similar life-critical medical equipment) unless authorized officers of the parties have executed a special agreement specifically governing such use.

Only those TI components which TI has specifically designated as military grade or "enhanced plastic" are designed and intended for use in military/aerospace applications or environments. Buyer acknowledges and agrees that any military or aerospace use of TI components which have **not** been so designated is solely at the Buyer's risk, and that Buyer is solely responsible for compliance with all legal and regulatory requirements in connection with such use.

TI has specifically designated certain components as meeting ISO/TS16949 requirements, mainly for automotive use. In any case of use of non-designated products, TI will not be responsible for any failure to meet ISO/TS16949.

Products

Audio	www.ti.com/audio
Amplifiers	amplifier.ti.com
Data Converters	dataconverter.ti.com
DLP® Products	www.dlp.com
DSP	dsp.ti.com
Clocks and Timers	www.ti.com/clocks
Interface	interface.ti.com
Logic	logic.ti.com
Power Mgmt	power.ti.com
Microcontrollers	microcontroller.ti.com
RFID	www.ti-rfid.com
OMAP Applications Processors	www.ti.com/omap
Wireless Connectivity	www.ti.com/wirelessconnectivity

Applications

Automotive and Transportation	www.ti.com/automotive
Communications and Telecom	www.ti.com/communications
Computers and Peripherals	www.ti.com/computers
Consumer Electronics	www.ti.com/consumer-apps
Energy and Lighting	www.ti.com/energy
Industrial	www.ti.com/industrial
Medical	www.ti.com/medical
Security	www.ti.com/security
Space, Avionics and Defense	www.ti.com/space-avionics-defense
Video and Imaging	www.ti.com/video

TI E2E Community

e2e.ti.com