

THIS DRAWING IS UNPUBLISHED. RELEASED FOR PUBLICATION 20
 © COPYRIGHT 20 BY - ALL RIGHTS RESERVED.

REVISIONS					
P	LTR	DESCRIPTION	DATE	DWN	APVD
A1		ECR-16-004324	24MAR2016	CH	CW
A2		ECR-16-011800	17AUG2016	QY	CW
A3		ECR-18-017123	07NOV2018	KW	CW
A4		ECR-19-006712	26APR2019	AL	CW

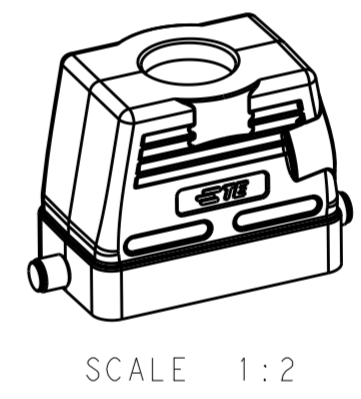
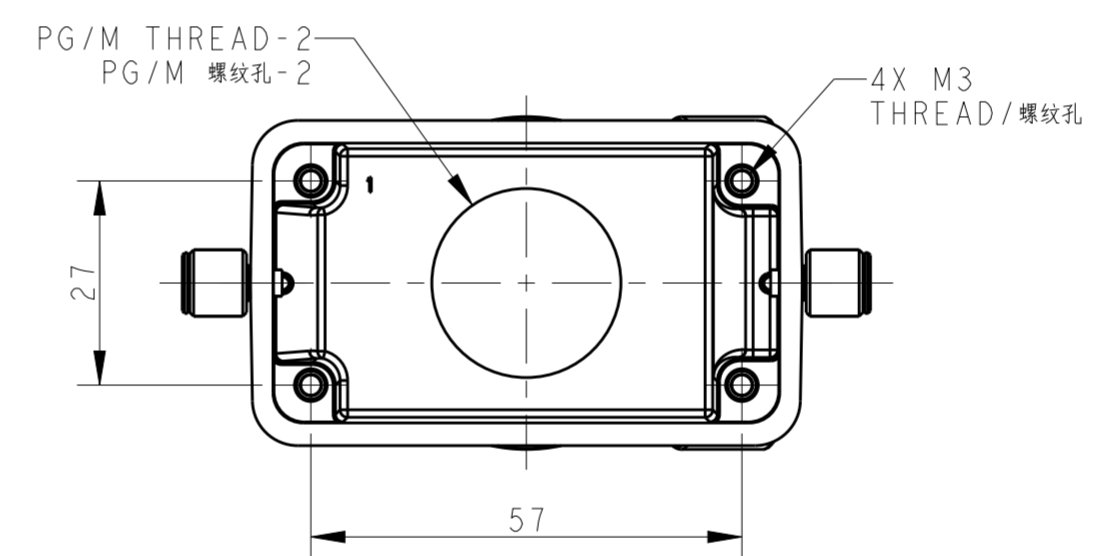
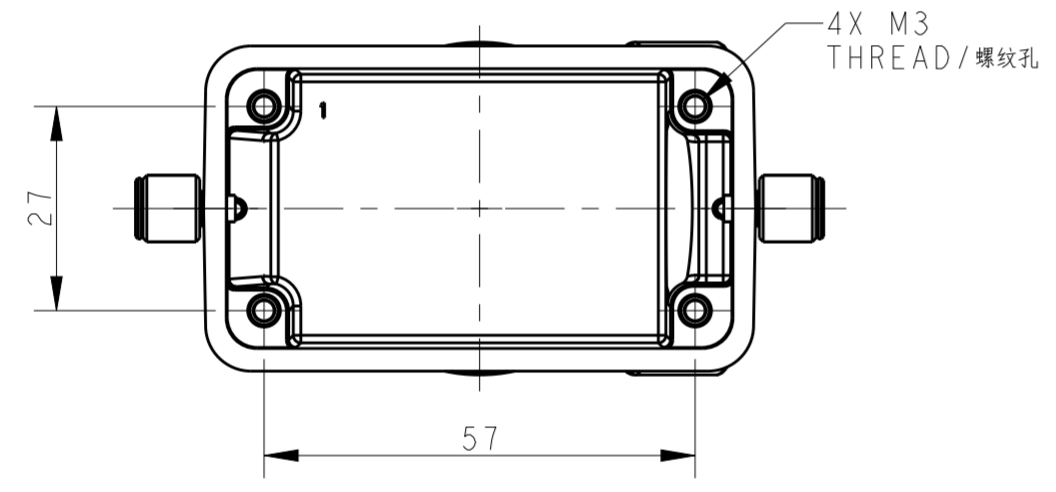
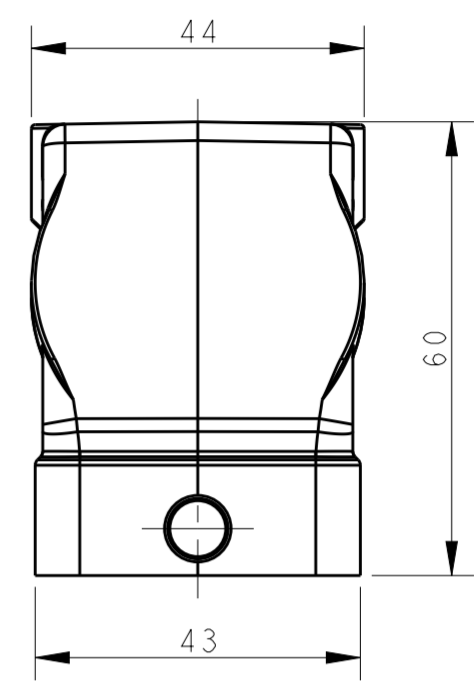
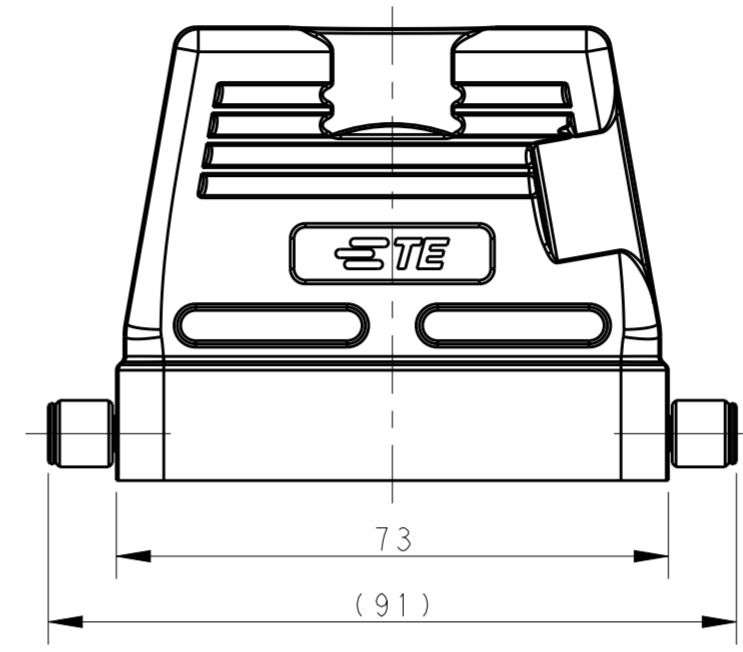
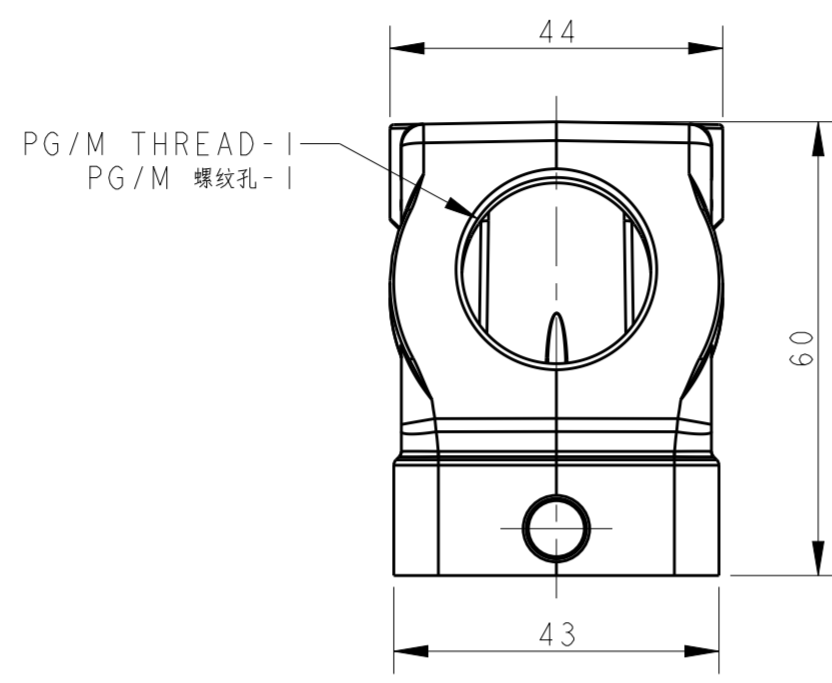
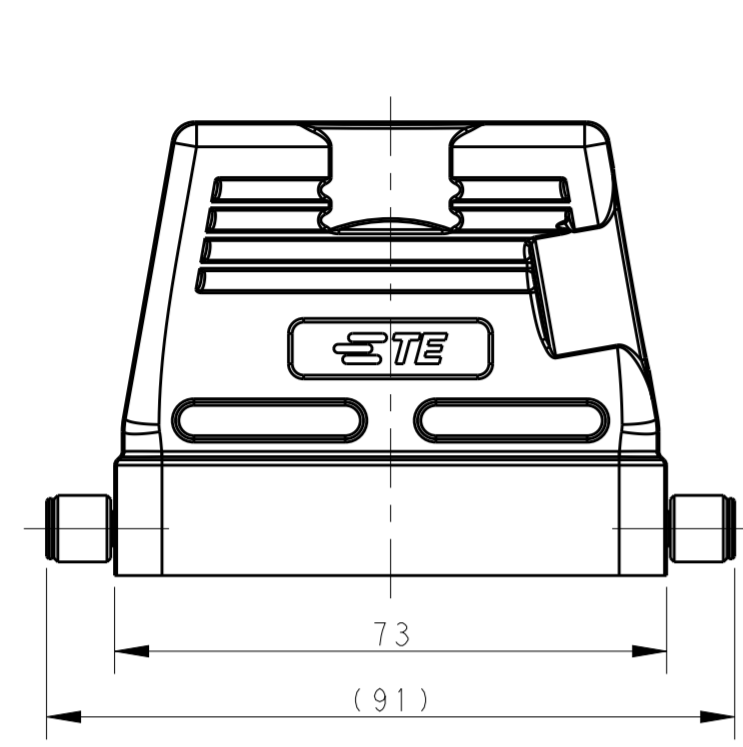

TYPE-1: H10B HOOD, LOW CONSTRUCTION, SIDE ENTRY, 2 EAR
 类型-1: H10B上壳, 低结构, 侧出, 2耳

TYPE-2: H10B HOOD, LOW CONSTRUCTION, TOP ENTRY, 2 EAR
 类型-2: H10B上壳, 低结构, 顶出, 2耳



TYPE-5: H10B HOOD, LOW CONSTRUCTION, NO ENTRY, 2 EAR
 OTHER SPEC REFER TO TYPE-1
 类型-5: H10B上壳, 低结构, 无出线孔, 2耳
 其它规格尺寸参照类型-1

NOTES:
 1. TECHNICAL CHARACTERISTICS:
 HOOD MATERIAL: DIE CAST ALUMINIUM ALLOY
 SURFACE: POWDER COATED, GREY
 DEGREE OF PROTECTION: IP65 (MATED)

注释:
 1. 技术参数:
 上壳材料: 铝合金
 表面处理: 粉末涂层, 灰色
 防护等级: IP65(配合)

THIS DRAWING IS A CONTROLLED DOCUMENT.		DWN DAVID.WANG 04JUN2015	STE TE Connectivity	
		CHK CHRIS.WANG 04JUN2015		
		APVD XIANG.XU 04JUN2015	NAME H10B-TS/TG/TSH/TGH-RO-M/PG	
DIMENSIONS: mm		PRODUCT SPEC 108-137013	SIZE CAGE CODE DRAWING NO RESTRICTED TO	
TOLERANCES UNLESS OTHERWISE SPECIFIED:		APPLICATION SPEC 114-137013	A200779 C-T13X010XXXX000	
0 PLC ±		WEIGHT -	SCALE 1:2 SHEET 1 OF 3 REV A4	
1 PLC ±		Customer Drawing		
2 PLC ±				
3 PLC ±				
4 PLC ±				
ANGLES ±				
FINISH -				
MATERIAL -				

THIS DRAWING IS UNPUBLISHED. RELEASED FOR PUBLICATION 20
 © COPYRIGHT 20 BY - ALL RIGHTS RESERVED.

REVISIONS				
P	LTR	DESCRIPTION	DATE	APVD
-	-	SEE SHEET 1	-	-

NOTES:
SEE SHEET 1

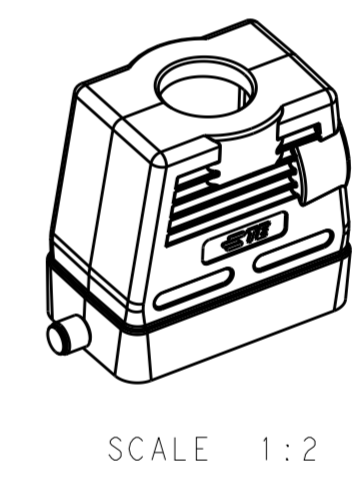
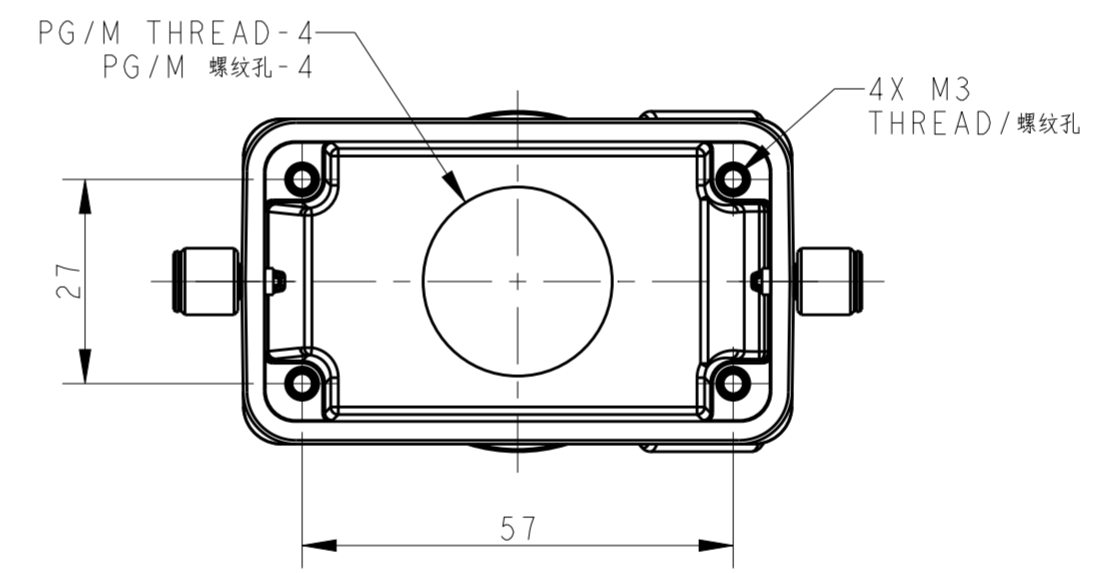
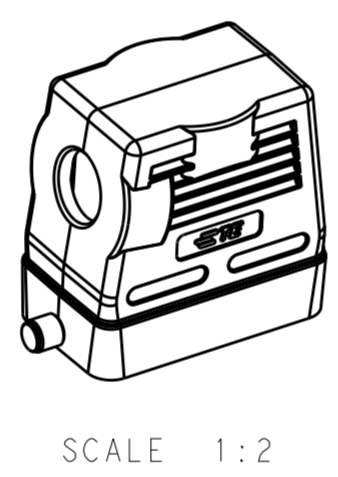
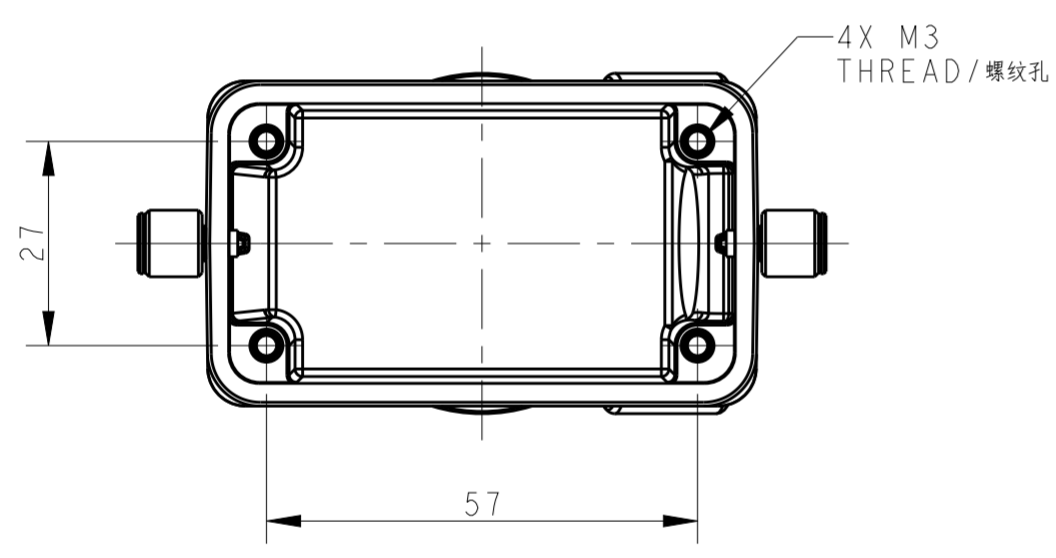
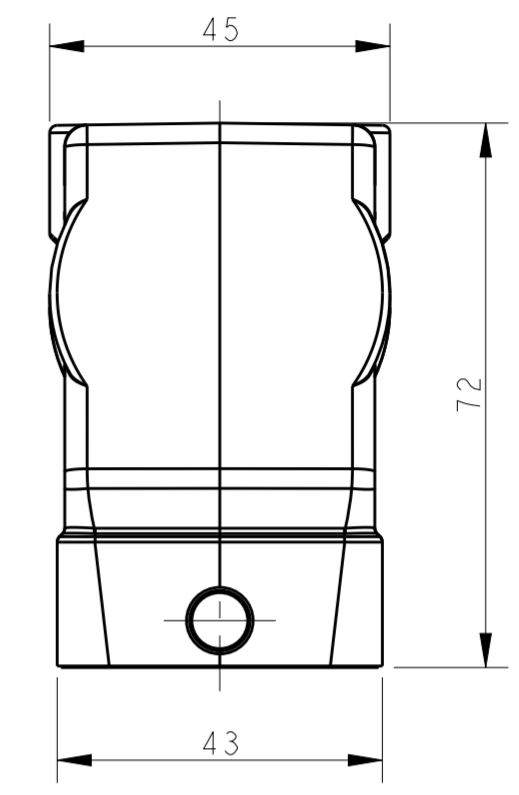
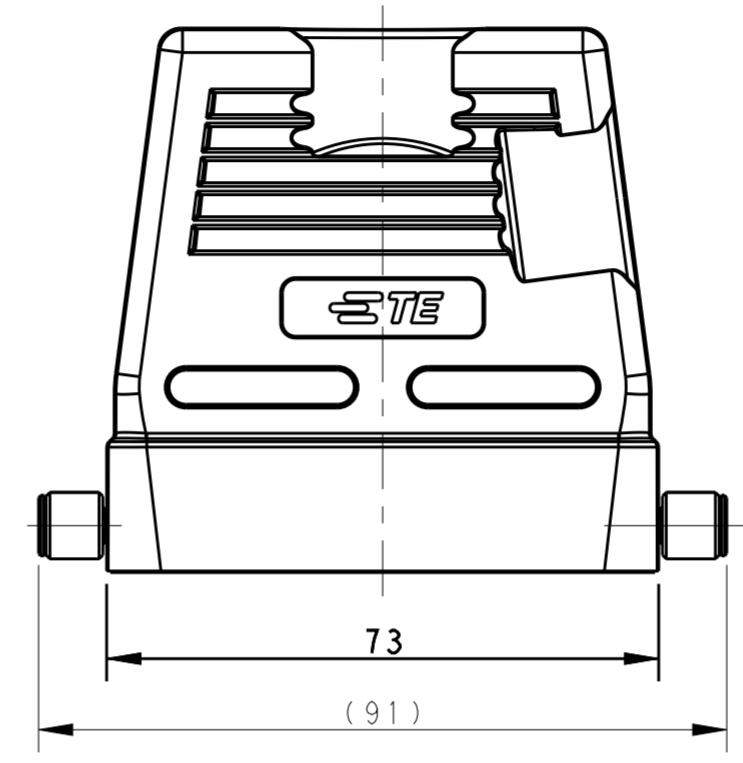
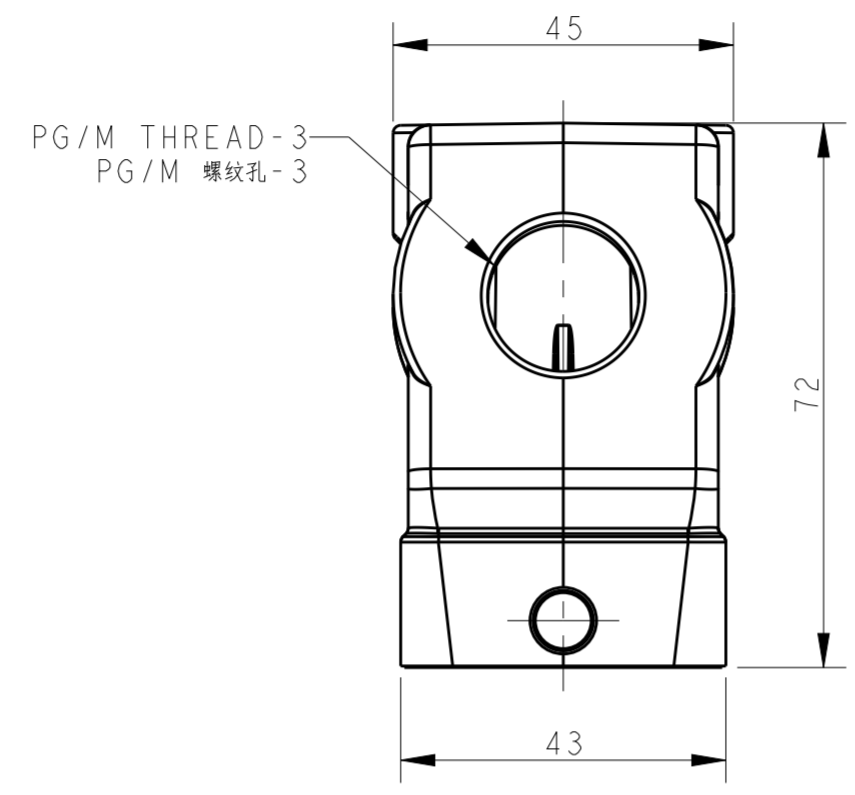
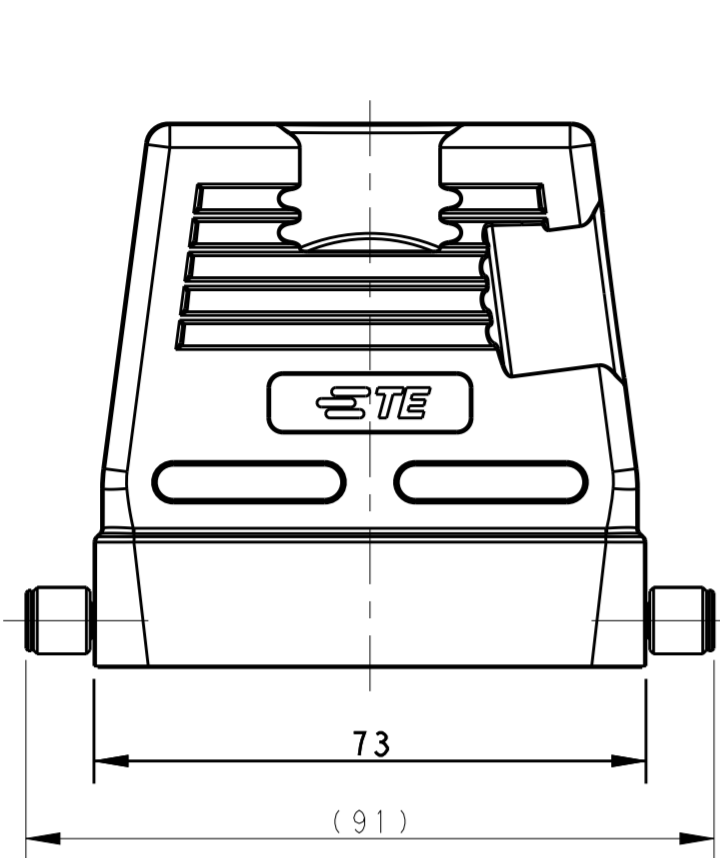

TYPE-3: H10B HOOD, HIGH CONSTRUCTION, SIDE ENTRY, 2 EAR
 类型-3: H10B上壳, 高结构, 侧出, 2耳

TYPE-4: H10B HOOD, HIGH CONSTRUCTION, TOP ENTRY, 2 EAR
 类型-4: H10B上壳, 高结构, 顶出, 2耳

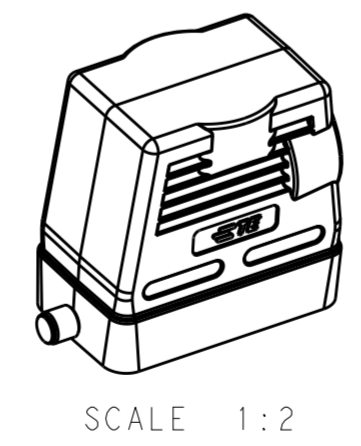

TYPE-6: H0B HOOD, HIGH CONSTRUCTION, NO ENTRY, 2 EAR
 OTHER SPEC REFER TO TYPE-3
 类型-6: H10B上壳, 高结构, 无出线孔, 2耳
 其它规格尺寸参照类型-3

THIS DRAWING IS A CONTROLLED DOCUMENT.		DWN DAVID.WANG 04JUN2015	TE Connectivity	
		CHK CHRIS.WANG 04JUN2015		
		APVD XIANG.XU 04JUN2015	NAME H10B-TS/TG/TSH/TGH-RO-M/PG	
DIMENSIONS: mm		PRODUCT SPEC 108-137013	SIZE CAGE CODE DRAWING NO RESTRICTED TO	
TOLERANCES UNLESS OTHERWISE SPECIFIED:		APPLICATION SPEC 114-137013	A200779 C-T13X010XXXX000	
0 PLC ±-		WEIGHT -	SCALE 1:1 SHEET 2 OF 3 REV A4	
1 PLC ±-		Customer Drawing		
2 PLC ±-				
3 PLC ±-				
4 PLC ±-				
ANGLES ±-				
FINISH ±-				

THIS DRAWING IS UNPUBLISHED. RELEASED FOR PUBLICATION 20
 © COPYRIGHT 20 BY - ALL RIGHTS RESERVED.

REVISIONS				
P	LTR	DESCRIPTION	DATE	DWN
-	-	SEE SHEET 1	-	-

NOTES:
SEE SHEET 1

PART NUMBER	PART DESCRIPTION	PG/M THREAD-1	PG/M THREAD-2	PG/M THREAD-3	PG/M THREAD-4	TYPE
料号	描述	PG/M 螺纹孔-1	PG/M 螺纹孔-2	PG/M 螺纹孔-3	PG/M 螺纹孔-4	类型
T1340100000-000	H10B-TGH-RO H10B HOOD, NO ENTRY HOLE, 2 EAR, HIGH CONSTRUCTION, POWDER COATED, GREY H10B上壳, 无出线孔, 2耳, 高结构, 灰色粉末喷涂	-	-	-	-	TYPE-6: H0B HOOD, HIGH CONSTRUCTION, NO ENTRY, 2 EAR 类型-6: H10B上壳, 高结构, 无出线孔, 2耳
T1340107134-000	H10B-TGH-RO-NPT3/4 H10B HOOD, TOP ENTRY NPT3/4, 2 EAR, HIGH CONSTRUCTION, POWDER COATED, GREY H10B上壳, 顶出NPT3/4, 2耳, 高结构, 灰色粉末喷涂	-	-	-	NPT3/4	TYPE-4: H10B HOOD, HIGH CONSTRUCTION, TOP ENTRY, 2 EAR 类型-4: H10B上壳, 高结构, 顶出, 2耳
T1340100132-000	H10B-TGH-RO-M32 H10B HOOD, TOP ENTRY M32, 2 EAR, HIGH CONSTRUCTION, POWDER COATED, GREY H10B上壳, 顶出M32, 2耳, 高结构, 灰色粉末喷涂	-	-	-	M32	
T1340100129-000	H10B-TGH-RO-PG29 H10B HOOD, TOP ENTRY PG29, 2 EAR, HIGH CONSTRUCTION, POWDER COATED, GREY H10B上壳, 顶出PG29, 2耳, 高结构, 灰色粉末喷涂	-	-	-	PG29	
T1340100125-000	H10B-TGH-RO-M25 H10B HOOD, TOP ENTRY M25, 2 EAR, HIGH CONSTRUCTION, POWDER COATED, GREY H10B上壳, 顶出M25, 2耳, 高结构, 灰色粉末喷涂	-	-	-	M25	
T1340100121-000	H10B-TGH-RO-PG21 H10B HOOD, TOP ENTRY PG21, 2 EAR, HIGH CONSTRUCTION, POWDER COATED, GREY H10B上壳, 顶出PG21, 2耳, 高结构, 灰色粉末喷涂	-	-	-	PG21	
T1330107134-000	H10B-TSH-RO-NPT3/4 H10B HOOD, SIDE ENTRY NPT3/4, 2 EAR, HIGH CONSTRUCTION, POWDER COATED, GREY H10B上壳, 侧出NPT3/4, 2耳, 高结构, 灰色粉末喷涂	-	-	NPT3/4	-	TYPE-3: H10B HOOD, HIGH CONSTRUCTION, SIDE ENTRY, 2 EAR 类型-3: H10B上壳, 高结构, 侧出, 2耳
T1330100132-000	H10B-TSH-RO-M32 H10B HOOD, SIDE ENTRY M32, 2 EAR, HIGH CONSTRUCTION, POWDER COATED, GREY H10B上壳, 侧出M32, 2耳, 高结构, 灰色粉末喷涂	-	-	M32	-	
T1330100129-000	H10B-TSH-RO-PG29 H10B HOOD, SIDE ENTRY PG29, 2 EAR, HIGH CONSTRUCTION, POWDER COATED, GREY H10B上壳, 侧出PG29, 2耳, 高结构, 灰色粉末喷涂	-	-	PG29	-	
T1330100125-000	H10B-TSH-RO-M25 H10B HOOD, SIDE ENTRY M25, 2 EAR, HIGH CONSTRUCTION, POWDER COATED, GREY H10B上壳, 侧出M25, 2耳, 高结构, 灰色粉末喷涂	-	-	M25	-	
T1330100121-000	H10B-TSH-RO-PG21 H10B HOOD, SIDE ENTRY PG21, 2 EAR, HIGH CONSTRUCTION, POWDER COATED, GREY H10B上壳, 侧出PG21, 2耳, 高结构, 灰色粉末喷涂	-	-	PG21	-	
T1330100120-000	H10B-TSH-RO-M20 H10B HOOD, SIDE ENTRY M20, 2 EAR, HIGH CONSTRUCTION, POWDER COATED, GREY H10B上壳, 侧出M20, 2耳, 高结构, 灰色粉末喷涂	-	-	M20	-	TYPE-5: H10B HOOD, LOW CONSTRUCTION, NO ENTRY, 2 EAR 类型-5: H10B上壳, 低结构, 无出线孔, 2耳
T1320100000-000	H10B-TG-RO H10B HOOD, NO ENTRY HOLE, 2 EAR, LOW CONSTRUCTION, POWDER COATED, GREY H10B上壳, 无出线孔, 2耳, 低结构, 灰色粉末喷涂	-	-	-	-	
T1320100132-000	H10B-TG-RO-M32 H10B HOOD, TOP ENTRY M32, 2 EAR, LOW CONSTRUCTION, POWDER COATED, GREY H10B上壳, 顶出M32, 2耳, 低结构, 灰色粉末喷涂	-	M32	-	-	
T1320100125-000	H10B-TG-RO-M25 H10B HOOD, TOP ENTRY M25, 2 EAR, LOW CONSTRUCTION, POWDER COATED, GREY H10B上壳, 顶出M25, 2耳, 低结构, 灰色粉末喷涂	-	M25	-	-	
T1320100120-000	H10B-TG-RO-M20 H10B HOOD, TOP ENTRY M20, 2 EAR, LOW CONSTRUCTION, POWDER COATED, GREY H10B上壳, 顶出M20, 2耳, 低结构, 灰色粉末喷涂	-	M20	-	-	
T1320100121-000	H10B-TG-RO-PG21 H10B HOOD, TOP ENTRY PG21, 2 EAR, LOW CONSTRUCTION, POWDER COATED, GREY H10B上壳, 顶出PG21, 2耳, 低结构, 灰色粉末喷涂	-	PG21	-	-	TYPE-2: H10B HOOD, LOW CONSTRUCTION, TOP ENTRY, 2 EAR 类型-2: H10B上壳, 低结构, 顶出, 2耳
T1320100116-000	H10B-TG-RO-PG16 H10B HOOD, TOP ENTRY PG16, 2 EAR, LOW CONSTRUCTION, POWDER COATED, GREY H10B上壳, 顶出PG16, 2耳, 低结构, 灰色粉末喷涂	-	PG16	-	-	
T1310100125-000	H10B-TS-RO-M25 H10B HOOD, SIDE ENTRY M25, 2 EAR, LOW CONSTRUCTION, POWDER COATED, GREY H10B上壳, 侧出M25, 2耳, 低结构, 灰色粉末喷涂	M25	-	-	-	
T1310100121-000	H10B-TS-RO-PG21 H10B HOOD, SIDE ENTRY PG21, 2 EAR, LOW CONSTRUCTION, POWDER COATED, GREY H10B上壳, 侧出PG21, 2耳, 低结构, 灰色粉末喷涂	PG21	-	-	-	
T1310100120-000	H10B-TS-RO-M20 H10B HOOD, SIDE ENTRY M20, 2 EAR, LOW CONSTRUCTION, POWDER COATED, GREY H10B上壳, 侧出M20, 2耳, 低结构, 灰色粉末喷涂	M20	-	-	-	
T1310100116-000	H10B-TS-RO-PG16 H10B HOOD, SIDE ENTRY PG16, 2 EAR, LOW CONSTRUCTION, POWDER COATED, GREY H10B上壳, 侧出PG16, 2耳, 低结构, 灰色粉末喷涂	PG16	-	-	-	TYPE-1: H10B HOOD, LOW CONSTRUCTION, SIDE ENTRY, 2 EAR 类型-1: H10B上壳, 低结构, 侧出, 2耳
T1310100113-000	H10B-TS-RO-PG13.5 H10B HOOD, SIDE ENTRY PG13.5, 2 EAR, LOW CONSTRUCTION, POWDER COATED, GREY H10B上壳, 侧出PG13.5, 2耳, 低结构, 灰色粉末喷涂	PG13.5	-	-	-	
T1310100016-000	H10B-TS-RO-M16 H10B HOOD, SIDE ENTRY M16, 2 EAR, LOW CONSTRUCTION, POWDER COATED, GREY H10B上壳, 侧出M16, 2耳, 低结构, 灰色粉末喷涂	M16	-	-	-	

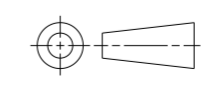
THIS DRAWING IS A CONTROLLED DOCUMENT.		DWN 04 JUN 2015 DAVID.WANG	 TE Connectivity
		CHK 04 JUN 2015 CHRIS.WANG	
		APVD 04 JUN 2015 XIANG.XU	
		NAME H10B-TS/TG/TSH/TGH-RO-M/PG	
DIMENSIONS: mm		PRODUCT SPEC 108-137013	SIZE CAGE CODE DRAWING NO RESTRICTED TO A200779 C-T13X010XXXX000 -
		APPLICATION SPEC 114-137013	
TOLERANCES UNLESS OTHERWISE SPECIFIED:		WEIGHT -	SCALE 1:1 SHEET 3 OF 3 REV A4 Customer Drawing
0 PLC ± 1 PLC ± 2 PLC ± 3 PLC ± 4 PLC ± ANGLES ± FINISH -			