

PART NUMBER	REVISION	DESCRIPTION	FEED TYPE
2150199-1	D	FINE CRIMP HEIGHT ADJUST	MECHANICAL
2150199-2	E	FINE CRIMP HEIGHT ADJUST	PNEUMATIC
7-2150199-1	D	MECHANICAL AND CRIMP TOOLING KIT	MECHANICAL
7-2150199-2	E	PNEUMATIC AND CRIMP TOOLING KIT	PNEUMATIC
7-2150199-7	A	CRIMP TOOLING KIT	-

ATLANTIC VERSION TERMINATOR INTERFACE ADAPTER

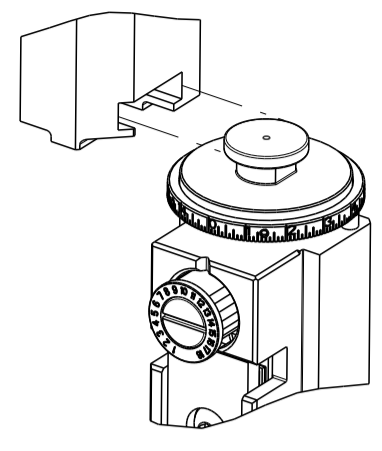

APPLICATOR DATA		
CRIMP	SIZE	TYPE
WIRE	2.79 mm [.110]	F
INSUL	4.57 mm [.180]	F
APPLICATOR INSTRUCTIONS 408-35043		

TERMINAL DATA: TE TERMINAL		TE CRIMP SPECIFICATION	
TERMINAL NAME: RECEPTACLE, POSITIVE-LOCK, .250 SERIES			
WIRE STRIP LENGTH		INSULATION DIAMETER RANGE	
4.39-5.16 mm [.173-.203 IN]		∅2.29-3.94 mm [.090-.155 IN]	
TERMINAL APPLICATION SPECIFICATION	114-2074		
TERMINALS APPLIED			
TE TERMINAL	TE TERMINAL	TE TERMINAL	TE TERMINAL
63854-1	63854-2		

WIRE SIZE	CRIMP HEIGHT mm [INCH]	CRIMP HEIGHT REFERENCE SETTING
14 AWG	1.85 +/- 0.05 [.073 +/- .002]	3.4
16 AWG	1.63 +/- 0.05 [.064 +/- .002]	5.6
18 AWG	1.47 +/- 0.05 [.058 +/- .002]	7.5

- RECOMMENDED SPARE PARTS
- REFER TO SUPPLIED INSTRUCTION SHEET FOR CLEANING, LUBRICATION AND STORAGE OF APPLICATOR.
- APPLY PART NUMBER 1-23419-5 LOCTITE TO THREADS OF ITEM 50. APPLY PART NUMBER 2-23419-6 LOCTITE TO THREADS OF ITEM 242.
- CRIMP HEIGHT REFERENCE SETTING WAS THE SETTING USED WHEN THE APPLICATOR WAS QUALIFIED AT THE FACTORY. ADJUSTMENT MAY BE NECESSARY WHEN RUNNING APPLICATOR IN THE FIELD.
- TERMINAL LUBRICANT IS RECOMMENDED.
- 6. UNLESS SPECIFIED OTHERWISE TORQUE VALUES SHALL BE USED PER DOCUMENT, 101-35000.

***WARNING**
ON INSTALLATION, SET WIRE DISC TO CRIMP HEIGHT REFERENCE SETTING FOR LARGEST WIRE SIZE. CRIMP HEIGHT REFERENCE SETTINGS GREATER THAN THE VALUE SHOWN MAY CAUSE DAMAGE TO THE CRIMP TOOLING, REFER TO THE INSTRUCTION SHEET FOR PROPER SETUP AND ADJUSTMENTS.

ATLANTIC VERSION
Shown on sheets 1 of 4 & 2 of 4
(Pacific version shown on sheets 3 of 4 & 4 of 4)

LOC	DIST	REVISIONS					
A	66	P	LTN	DESCRIPTION	DATE	DWN	APVD
		B		ECR-14-003773	14MAR2014	KH	UG
		C		ECR-17-011454	07AUG2017	TB	TE
		D		ECR-18-014691	17SEP2018	FZ	KZ
		E		ECR-20-004256	20MAR2020	TB	RK

-	1	-	1	-	2119641-1	FEED CAM, AIR FEED	248					
-	1	1	1	1	2119082-9	CAM, SNAIL, INSULATION ADJUSTMENT	244					
-	1	1	1	1	2079764-1	WASHER, WAVE SPRING, CREST-TO-CREST	243					
-	1	1	1	1	2119083-1	RETAINER, INSULATION DIAL	242					
-	-	1	-	1	2119580-1	MECHANICAL FEED ASSEMBLY	239					
-	1	-	1	-	2844940-3	AIR FEED MODULE	238					
-	1	1	1	1	1-18028-0	WASHER, FLAT, REG M8	192					
-	1	1	1	1	6-993111-6	PIN, SLOTTED SPRING 3.0 X 14.0	177					
-	1	1	1	1	8-22280-7	SPRING, COMPRESSION	176					
-	1	1	1	1	1752353-2	GUIDE PIN, HOLDDOWN	175					
-	1	1	1	1	1901680-2	GUIDE PIN, HOLDDOWN	174					
-	REF	REF	REF	REF	994970-2	COUNTER, MAGNETIC	164					
-	1	1	1	1	2119955-2	ASSY, LUBRICATOR, END FEED	84					
-	1	1	1	1	455888-5	SPACER, CRIMPER	82					
-	1	1	1	1	1803607-4	DOCUMENTATION PACKAGE	71					
-	2	2	2	2	2-18032-2	SCR, SET, FLT PNT, M3 X 10.0	70					
-	1	1	1	1	2119740-1	TAG, IDENTIFICATION	67					
-	2	2	2	2	2168078-1	SCREW, DRIVE, RH, RoHS, 2 x .188	66					
-	1	1	1	1	1901681-1	HOLDDOWN, TERMINAL	65					
-	2	2	2	2	2168400-5	SHCS, LOW HEAD, RoHS, M4 X 20	64					
-	1	1	1	1	2168083-2	SCR, SKT HD CAP, RoHS, M4 X 8.0	60					
-	1	1	1	1	5-18022-5	SCR, HEX HD CAP, M4 X 6.0	59					
-	-	1	-	1	2063961-1	FEED FINGER	58					
-	3	3	3	3	2168400-4	SHCS, LOW HEAD, RoHS, M4 X 8	57					
-	2	2	2	2	2168083-3	SCR, SKT HD CAP, RoHS, M4 X 12.0	56					
-	2	2	2	2	5018030-1	NUT, HEX, REG, RoHS, M3	54					
-	2	2	2	2	986965-8	NUT, LOCK, HEX, TORQUE (M4)	53					
-	1	1	1	1	1-5018030-0	NUT, HEX, REG, RoHS, M3.5	52					
-	1	-	1	-	2063961-1	FEED FINGER	51					
-	1	1	1	1	1-1752354-3	STANDOFF, HOLD-DOWN	50					
-	1	2	1	2	18023-9	SCR, SKT HD CAP M4 X 6.0	49					
-	-	1	-	1	2119652-1	FEED CAM, PRE FEED	48					
-	-	1	-	1	2119653-1	FEED CAM, POST FEED	47					
-	1	1	1	1	2119655-5	APPLICATOR BASIC ASSEMBLY, EF	46					
-	1	1	1	1	1803517-1	RAM ASSEMBLY, EF ATLANTIC	44					
-	1	1	1	1	1803602-1	SCR, BHSC, RoHS (M8 X 25)	41					
-	7	7	7	7	1-18028-2	WASHER, FLAT, REG M4	33					
-	2	2	2	2	2168083-9	SCR, SKT HD CAP, RoHS, M4 X 20	31					
-	2	2	2	2	2168083-2	SCR, SKT HD CAP, RoHS, M4 X 8.0	29					
-	1	1	1	1	240639-1	STRIPPER (MACHINING)	27					
-	2	2	2	2	1-2168083-5	SCR, SKT HD CAP, RoHS, M4 X 30	25					
-	1	1	1	1	1752371-1	PLATE, STRIP GUIDE	24					
-	1	1	1	1	240825-2	PLATE, STRIP HOLD DOWN	23					
-	2	2	2	2	2-22281-3	SPRING, COMPRESSION	22					
-	1	1	1	1	1803292-4	DRAG	20					
-	2	2	2	2	1901259-5	GUIDE, LOWER STRIP	18					
-	4	4	4	4	1-2079383-1	SCR, BHSC, RoHS (M6 X 12)	17					
-	1	1	1	1	240641-6	SPACER	16					
-	1	1	1	1	1752360-1	SPACER, HOLD-DOWN	13					
-	1	1	1	1	240644-1	PLATE, REAR SHEAR	11					
-	1	1	1	1	690482-5	PLATE, FRONT SHEAR	9					
-	1	2	2	1	1-1803000-2	ANVIL, COMBINATION, END FEED	8					
-	1	1	1	1	2217206-7	BLADE, SLUG	7					
-	1	1	1	1	4-240641-1	SPACER	5					
-	1	1	1	1	238011-4	BLOCK, CRIMPER SPACER	4					
-	1	2	2	1	2-1633961-7	CRIMPER, INSULATION F PREMIUM	3					
-	1	1	1	1	455888-8	SPACER, CRIMPER	2					
-	1	2	2	1	2-456408-8	CRIMPER, WIRE PREMIUM	1					
-	77	-	72	-	71	-	2	-	1	PART NO	DESCRIPTION	ITEM NO

DIMENSIONS:		TOLERANCES UNLESS OTHERWISE SPECIFIED:		DWN		CHK		APVD		SHEET	
mm	0 PLC ±	1 PLC ±	2 PLC ±	3 PLC ±	4 PLC ±	5 PLC ±	6 PLC ±	7 PLC ±	8 PLC ±	9 PLC ±	10 PLC ±
MATERIAL:		FINISH:		WEIGHT:		SCALE:		SHEET:		REV:	
-		-		-		1:1		1 OF 4		E	

LOC	DIST	REV	DESCRIPTION	DATE	OWN	APVD
A	66		SEE SHEET 1			

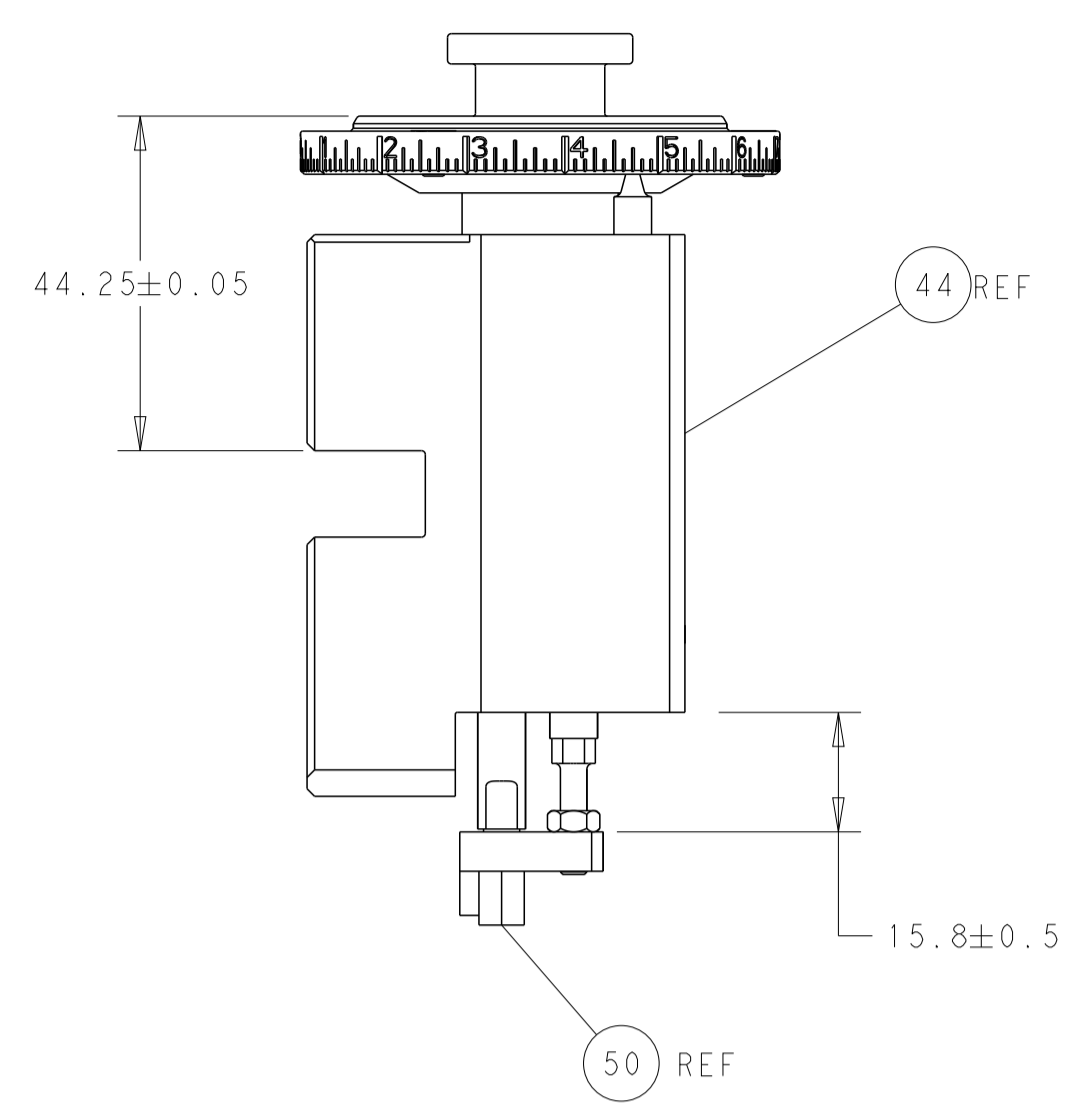

RAM AND HOLDDOWN SET-UP

FEED TYPE
MECHANICAL

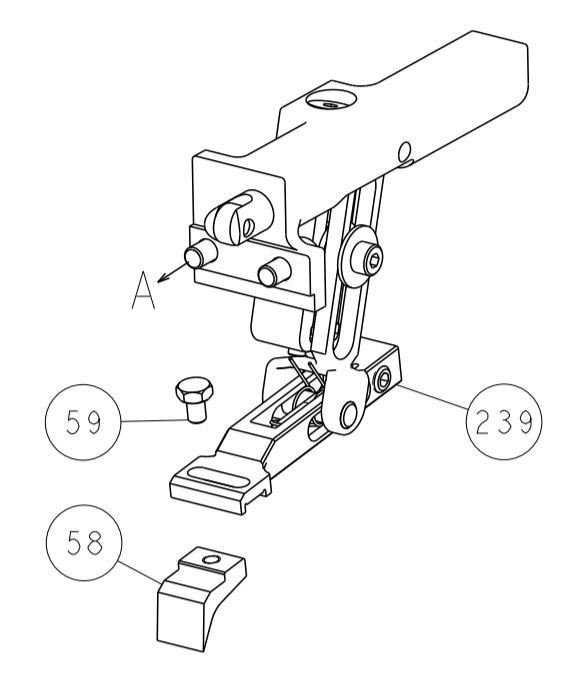

PNEUMATIC

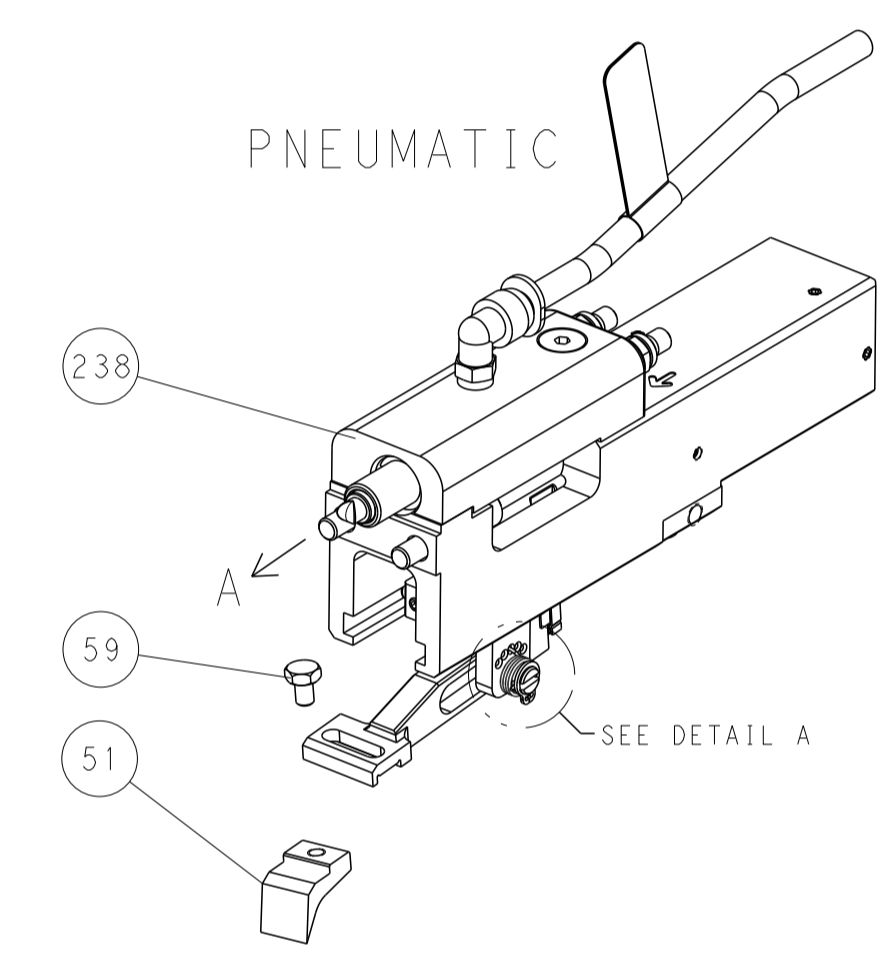

FEED SPRING
SETTING POSITION

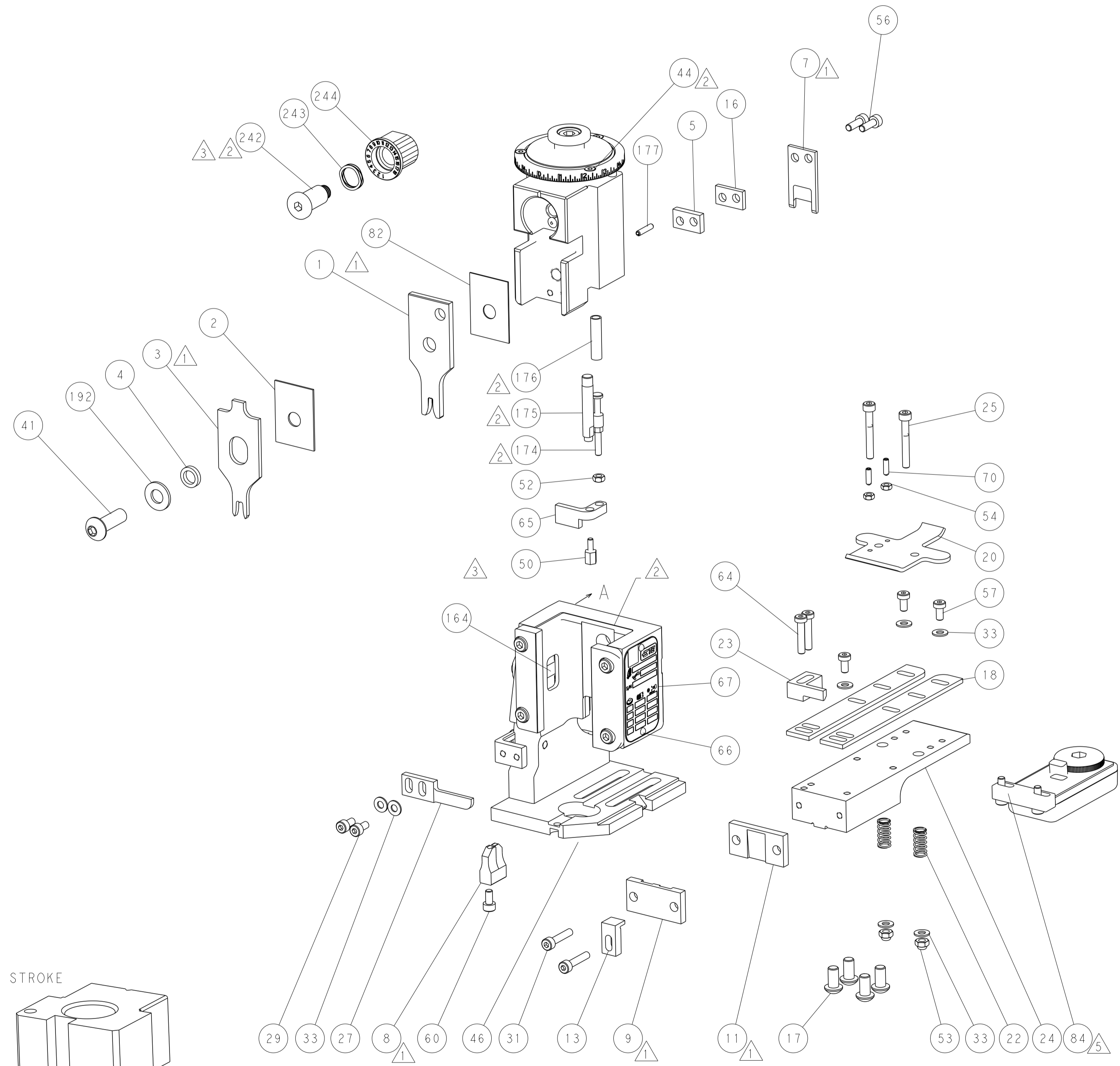
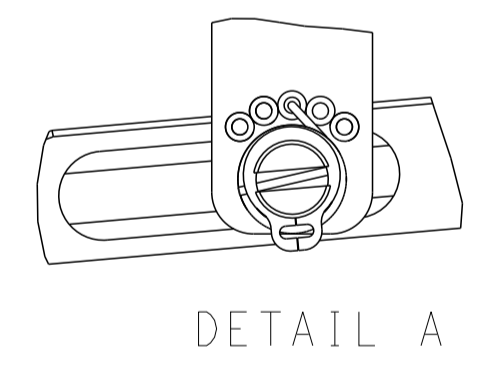

CAM POSITIONS

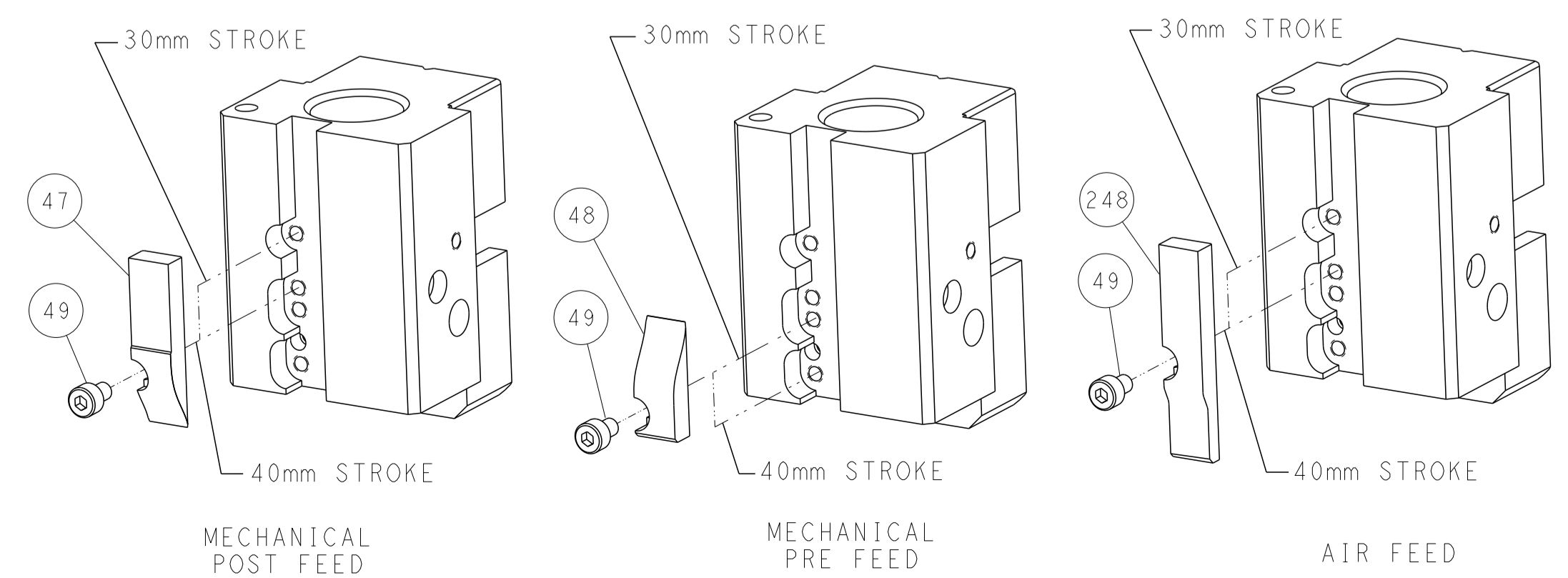

ATLANTIC VERSION
 Shown on sheets 1 of 4 & 2 of 4
 (Pacific version shown on sheets 3 of 4 & 4 of 4)

<small>THIS DRAWING IS UNPUBLISHED. RELEASED FOR PUBLICATION BY TYCO ELECTRONICS CORPORATION. ALL RIGHTS RESERVED.</small>		DWN: K. HUANG 07MAR2012 CHK: S. XI 07MAR2012 APVD: S. XI 07MAR2012	TE Connectivity Harrisburg, PA 17105-3608
DIMENSIONS: mm TOLERANCES UNLESS OTHERWISE SPECIFIED: 0 PLC ± 1 PLC ± 2 PLC ± 3 PLC ± 4 PLC ± ANGLES ± FINISH		NAME: Ocean End Feed Applicator SIZE: A1 CAGE CODE: 00779 DRAWING NO: C=2150199	RESTRICTED TO: - SCALE: 1:1 SHEET: 2 of 4 REV: E
MATERIAL: - FINISH: -		WEIGHT: - APPLICATION SPEC: - PRODUCT SPEC: -	Customer Accessible Production Drawing

LOC		DIST		REVISIONS			
A	66	P	LTM	DESCRIPTION	DATE	OWN	APVD
		-		SEE SHEET 1			

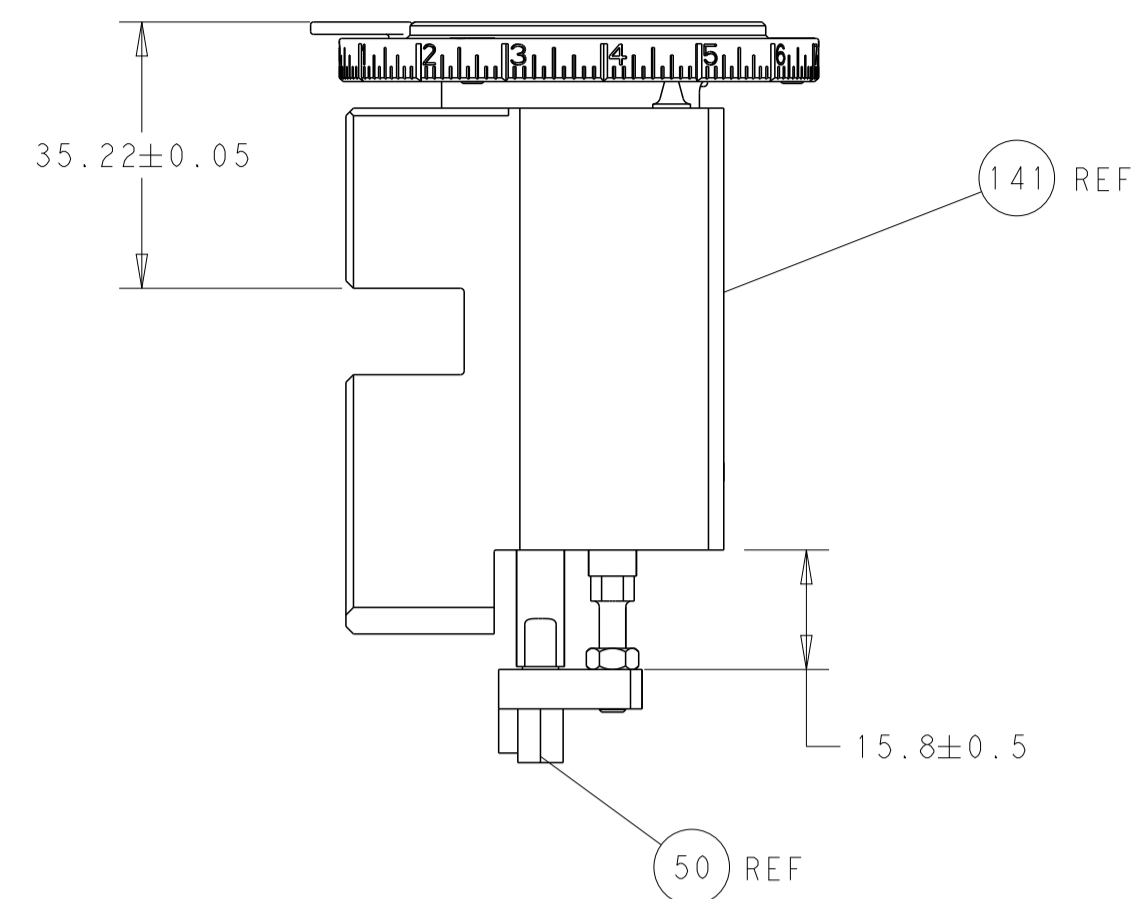

RAM AND HOLDDOWN SET-UP

FEED TYPE
MECHANICAL

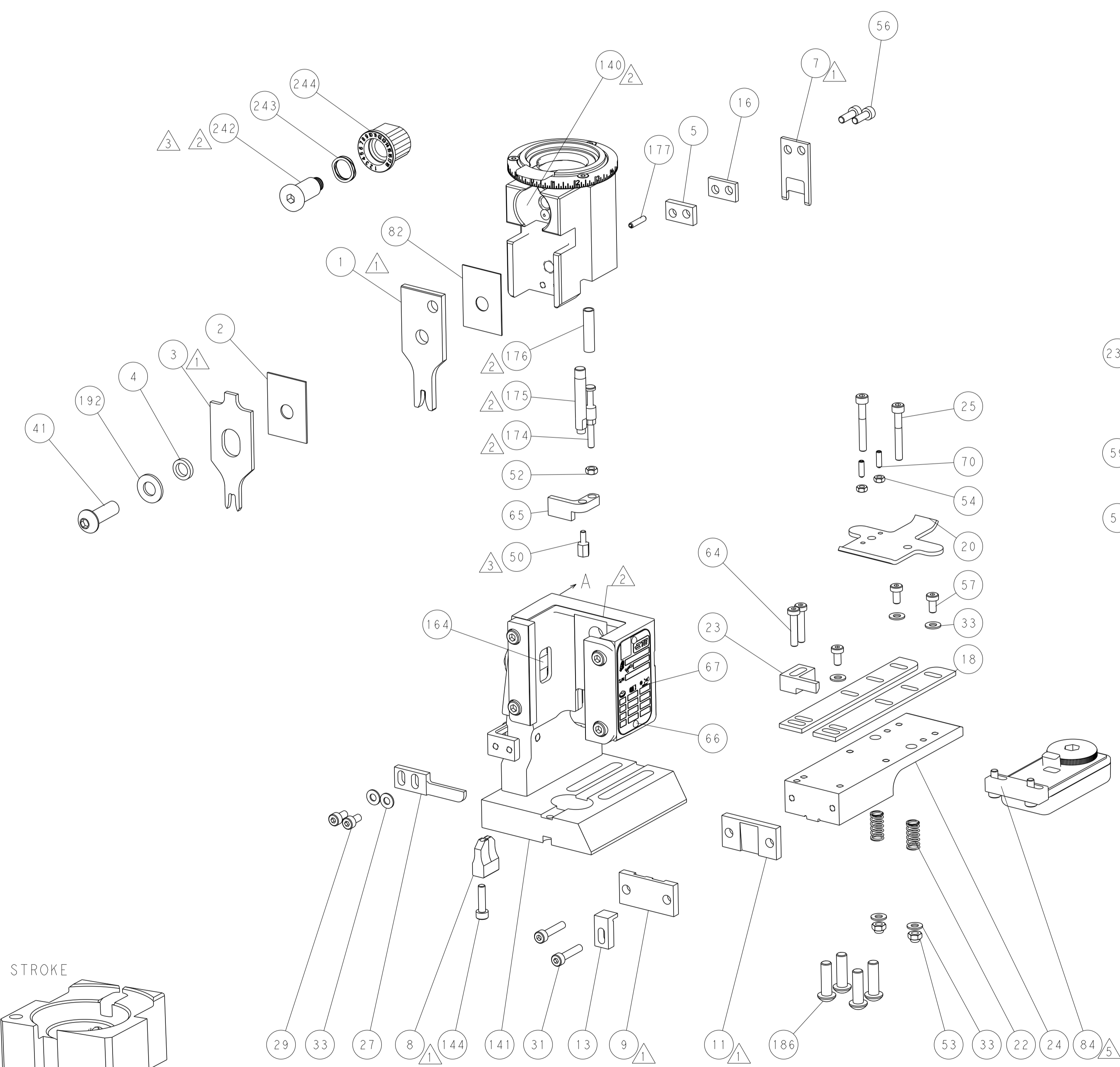
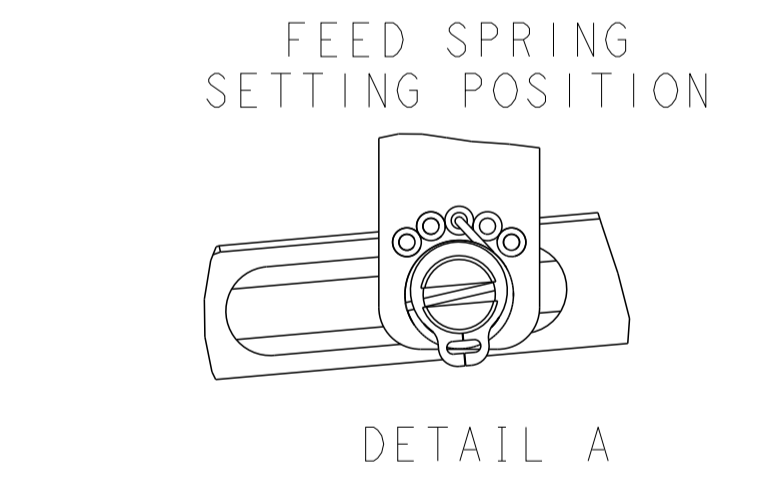
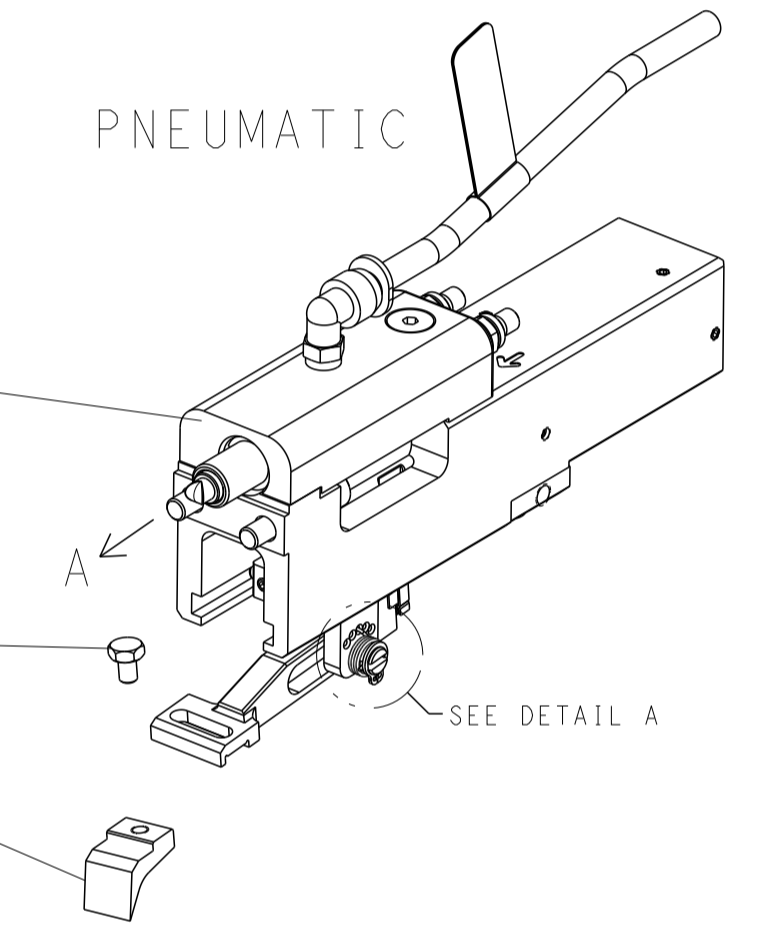
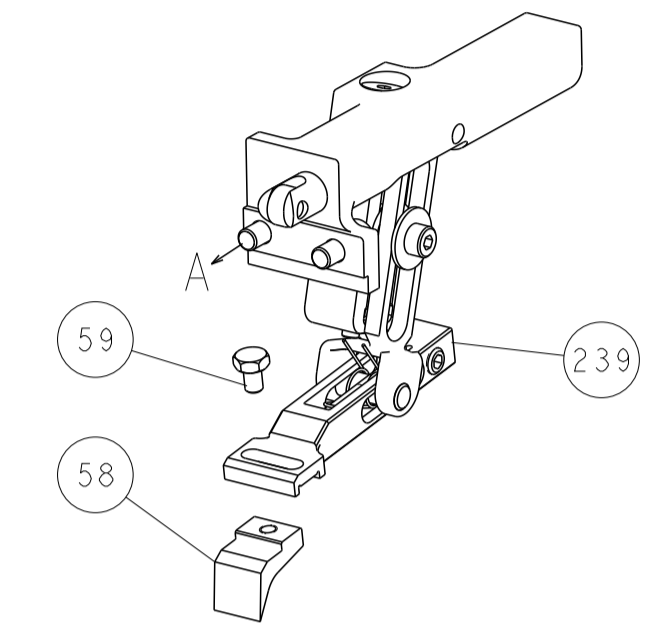

CAM POSITIONS

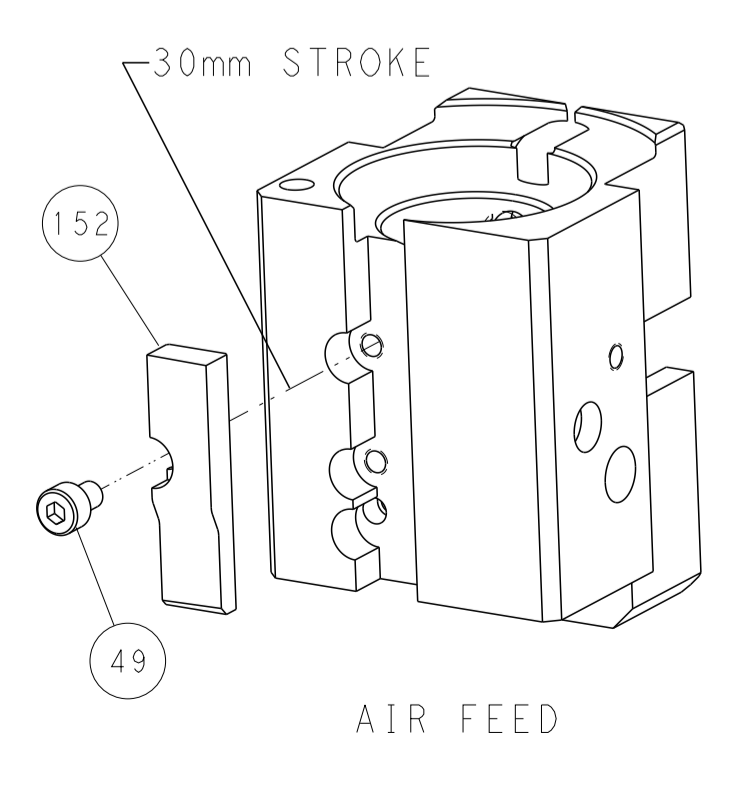
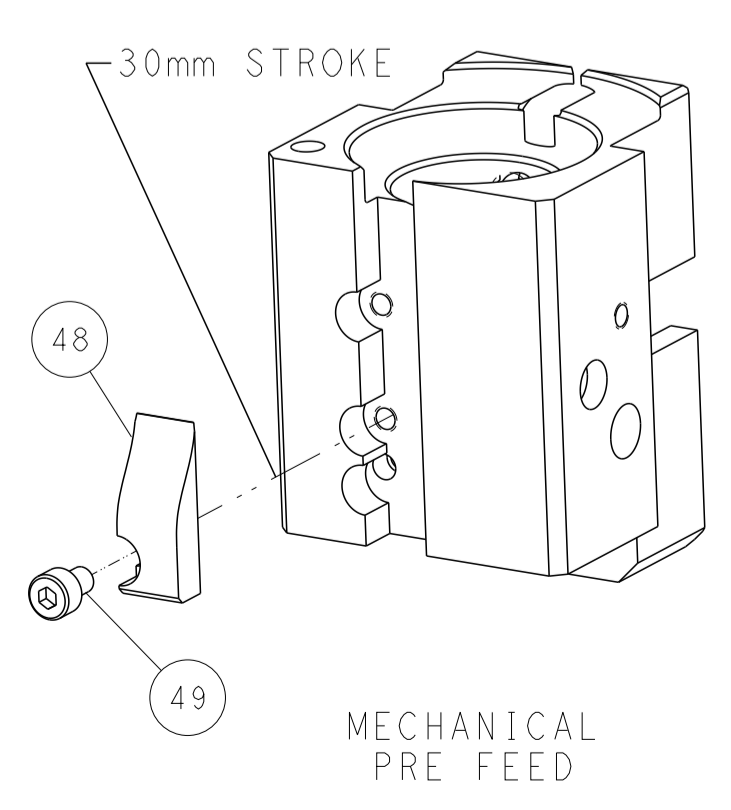
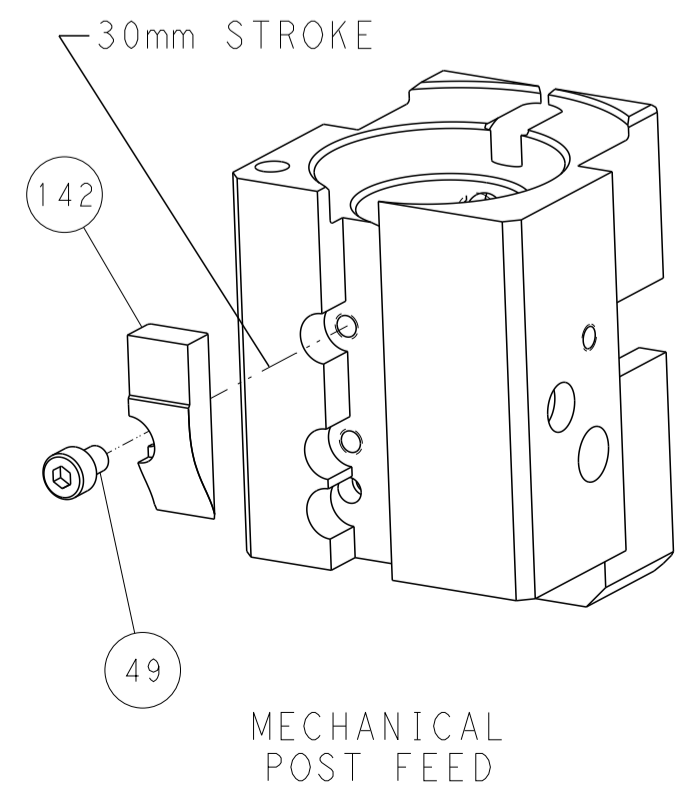

PACIFIC VERSION
 Shown on sheets 3 of 4 & 4 of 4
 (Atlantic version shown on sheets 1 of 4 & 2 of 4)

DIMENSIONS:		TOLERANCES UNLESS OTHERWISE SPECIFIED:		DWN K. HUANG 07MAR2012		STE TE Connectivity	
mm	0 PLC ±	1 PLC ±	2 PLC ±	3 PLC ±	4 PLC ±	5 PLC ±	Harrisburg, PA 17105-3608
MATERIAL:	FINISH:	WEIGHT:	SCALE:	SIZE:	CAGE CODE:	DRAWING NO:	RESTRICTED TO:
			1:1	A1	00779	©=2150199	