

PART NUMBER	REVISION	DESCRIPTION	FEED TYPE
2151985-1	C	FINE CRIMP HEIGHT ADJUST	MECHANICAL
2151985-2	C	FINE CRIMP HEIGHT ADJUST	PNEUMATIC
7-2151985-1	C	MECHANICAL AND CRIMP TOOLING KIT	MECHANICAL
7-2151985-2	C	PNEUMATIC AND CRIMP TOOLING KIT	PNEUMATIC
7-2151985-7	A	CRIMP TOOLING KIT	-

ATLANTIC VERSION TERMINATOR INTERFACE ADAPTER

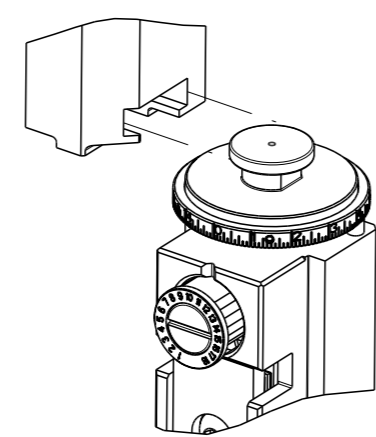

APPLICATOR DATA		
CRIMP	SIZE	TYPE
WIRE	1.40 mm [.055]	F
INSUL	1.57 mm [.062]	O

APPLICATOR INSTRUCTIONS
408-35042

TERMINAL DATA: TE TERMINAL		TE CRIMP SPECIFICATION	
TERMINAL NAME: CONTACT, TWIN LEAF			
WIRE STRIP LENGTH		INSULATION DIAMETER RANGE	
3.18-3.96 mm [.125-.156 IN]		Ø1.22-1.52 mm [.048-.060 IN]	
TERMINAL APPLICATION SPECIFICATION	114-9004		
TERMINALS APPLIED			
TE TERMINAL	TE TERMINAL	TE TERMINAL	TE TERMINAL
583853-1	583853-8	1-583853-3	5-583853-3
531477-1	5-531477-2	5-531477-4	

WIRE SIZE	CRIMP HEIGHT mm [INCH]	CRIMP HEIGHT REFERENCE SETTING
20 AWG OR 0.50mm2	1.02 +/- 0.05 [.040 +/- .002]	5.2
0.35mm2	0.92 +/- 0.05 [.036 +/- .002]	6.4
22 AWG OR 0.30mm2	0.92 +/- 0.05 [.036 +/- .002]	6.4
0.25mm2	0.86 +/- 0.05 [.034 +/- .002]	7.0
24 AWG OR 0.20mm2	0.84 +/- 0.05 [.033 +/- .002]	7.2

- RECOMMENDED SPARE PARTS
- REFER TO SUPPLIED INSTRUCTION SHEET FOR CLEANING, LUBRICATION AND STORAGE OF APPLICATOR.
- APPLY PART NUMBER 2-23419-6 LOCTITE TO THREADS OF ITEM 242.
- CRIMP HEIGHT REFERENCE SETTING WAS THE SETTING USED WHEN THE APPLICATOR WAS QUALIFIED AT THE FACTORY. ADJUSTMENT MAY BE NECESSARY WHEN RUNNING APPLICATOR IN THE FIELD.
- UNLESS SPECIFIED OTHERWISE TORQUE VALUES SHALL BE USED PER DOCUMENT, 101-35000.

***WARNING**
ON INSTALLATION, SET WIRE DISC TO CRIMP HEIGHT REFERENCE SETTING FOR LARGEST WIRE SIZE. CRIMP HEIGHT REFERENCE SETTINGS GREATER THAN THE VALUE SHOWN MAY CAUSE DAMAGE TO THE CRIMP TOOLING. REFER TO THE INSTRUCTION SHEET FOR PROPER SETUP AND ADJUSTMENTS.

ATLANTIC VERSION
Shown on sheets 1 of 4 & 2 of 4
(Pacific version shown on sheets 3 of 4 & 4 of 4)

LOC	DIST	REVISIONS					
A	66	#	LYR	DESCRIPTION	DATE	OWN	APVD
		B		ECR-18-007107	09MAY2018	MZ	CT
		C		ECR-18-010235	02JUL2018	YY	TE

-	1	-	1	-	2119640-1	PUSH ROD, AIR FEED	250	
-	1	-	1	-	1803259-1	BUSHING, FLANGED	249	
-	1	-	1	-	2119641-1	FEED CAM, AIR FEED	248	
-	1	1	1	1	2119082-9	CAM, SNAIL, INSULATION ADJUSTMENT	244	
-	1	1	1	1	2079764-1	WASHER, WAVE SPRING, CREST-TO-CREST	243	
-	1	1	1	1	2119083-1	RETAINER, INSULATION DIAL	242	
-	2	2	2	2	7-18023-7	SCR, SKT HD CAP M3 X 4.0	241	
-	-	1	-	1	2119580-1	MECHANICAL FEED ASSEMBLY	239	
-	1	-	1	-	2063440-1	AIR FEED MODULE	238	
-	1	1	1	1	356885-4	STOP, SHEAR	237	
-	2	-	2	-	21045-3	RING, RETAIN, EXTERN, 3/16 CRESCENT	172	
-	REF	REF	REF	REF	994970-2	COUNTER, MAGNETIC	164	
-	1	-	1	-	240638-1	SPRING, FEED FINGER	163	
-	1	-	1	-	3-23627-7	PIN, RETAIN, GRVD, 3/16 X .854	137	
-	1	-	1	-	2119799-1	HOLDER, FEED FINGER, AF	136	
-	1	1	1	1	1-18028-2	WASHER, FLAT, REG M4	119	
-	1	1	1	1	2844908-1	SCREW, LOCKING	99	
-	1	1	1	1	2844907-1	POST, LOCKING	98	
-	1	1	1	1	1-690438-0	FRONT STRIP GUIDE	96	
-	2	2	2	2	2168083-1	SCR, SKT HD CAP, RoHS, M3 X 8.0	95	
-	1	1	1	1	455888-7	SPACER, CRIMPER	82	
-	1	1	1	1	1-240641-3	SPACER	81	
-	1	1	1	1	1633782-2	FENCE	78	
-	1	1	1	1	5-547505-2	SPRING, COMPRESSION	77	
-	2	2	2	2	2168083-1	SCR, SKT HD CAP, RoHS, M3 X 8.0	77	
-	1	1	1	1	854769-4	HOLDER, INS	74	
-	1	1	1	1	1803607-1	DOCUMENTATION PACKAGE	71	
-	1	1	1	1	2119740-1	TAG, IDENTIFICATION	67	
-	2	2	2	2	2168078-1	SCREW, DRIVE, RH, RoHS, 2 x .188	66	
-	2	2	2	2	2-18032-5	SCR, SET, FLT PNT, M5 X 20.0	61	
-	1	1	1	1	2168083-2	SCR, SKT HD CAP, RoHS, M4 X 8.0	60	
-	1	1	1	1	5-18022-5	SCR, HEX HD CAP, M4 X 6.0	59	
-	1	1	1	1	21028-2	PIN, SLOTTED SPRING .062 X .250	58	
-	1	1	1	1	1338685-1	PAWL, FEED	56	
-	4	4	4	4	2168083-3	SCR, SKT HD CAP, RoHS, M4 X 12.0	54	
-	2	2	2	2	2168083-9	SCR, SKT HD CAP, RoHS, M4 X 20	53	
-	1	2	1	2	18023-9	SCR, SKT HD CAP M4 X 6.0	49	
-	-	1	-	1	2119652-1	FEED CAM, PRE FEED	48	
-	-	1	-	1	2119653-1	FEED CAM, POST FEED	47	
-	1	1	1	1	1803583-9	APPLICATOR BASIC ASSEMBLY, SF	46	
-	1	1	1	1	1803515-1	RAM ASSEMBLY, SF ATLANTIC	44	
-	1	1	1	1	1803602-1	SCR, BHSC, RoHS (M8 X 25)	41	
-	2	2	2	2	2079383-5	SCR, BHSC, RoHS (M4 X 20)	33	
-	2	2	2	2	2-2844962-3	SPACER, CYLINDRICAL, STRIP GUIDE	30	
-	1	1	1	1	2844992-3	ASSEMBLY, STRIP GUIDE	29	
-	1	1	1	1	1-455888-0	SPACER, CRIMPER	28	
-	2	2	2	2	22283-1	SPRING, COMPRESSION	27	
-	1	1	1	1	356835-1	LEVER, DRAG RELEASE	26	
-	1	1	1	1	240792-1	DRAG, TERMINAL	25	
-	1	1	1	1	1320928-2	STRIP GUIDE	24	
-	1	1	1	1	980371-4	SCR, SKT HD SHLDR 5.0 DIA X 6.0	23	
-	1	1	1	1	2168083-2	SCR, SKT HD CAP, RoHS, M4 X 8.0	21	
-	1	1	1	1	1-18028-2	WASHER, FLAT, REG M4	20	
-	1	1	1	1	2119533-1	STRIPPER, SIDE FEED	19	
-	1	1	1	1	1-690518-9	HOLD DOWN, TERMINAL	18	
-	1	1	1	1	690463-1	FLOATING SHEAR, REAR	17	
-	2	2	2	2	1-2168083-1	SCR, SKT HD CAP, RoHS, M3 X 6	16	
-	1	1	1	1	690691-9	PLATE, REAR SHEAR	15	
-	1	1	1	1	2119862-1	SHEAR HOLDER, REAR	14	
-	2	2	2	2	2119806-1	INSERT, SHEAR	13	
-	2	2	2	2	3-22280-3	SPRING, COMPRESSION	12	
-	1	1	1	1	1-356885-4	STOP, SHEAR	11	
-	1	1	1	1	2119805-1	SHEAR HOLDER, FRONT	10	
-	1	1	1	1	1803095-1	FLOATING SHEAR, FRONT	9	
-	1	2	2	1	1	2-1333201-8	ANVIL, COMBINATION	8
-	1	1	1	1	2-240641-2	SPACER	7	
-	1	1	1	1	690468-1	DEPRESSOR SHEAR, REAR	6	
-	1	1	1	1	2119780-5	DEPRESSOR, SHEAR	5	
-	1	1	1	1	2-238011-2	BLOCK, CRIMPER SPACER	4	
-	1	2	2	1	1	1633966-6	CRIMPER, INSULATION O	3
-	1	1	1	1	455888-4	SPACER, CRIMPER	2	
-	1	2	2	1	1	2-456402-6	CRIMPER, WIRE PREMIUM	1
-	77	-72	-71	-2	-1	PART NO	DESCRIPTION	ITEM NO

DIMENSIONS:		TOLERANCES UNLESS OTHERWISE SPECIFIED:		OWN	CHK	APVD	DATE	NAME	
mm	0 PLC ±	1 PLC ±	2 PLC ±	H. HUANG	L. ZHANG	U. GUO	20JUN2013	Ocean Side Feed Applicator	
	3 PLC ±	4 PLC ±	ANGLES FINISH					Customer Accessible Production Drawing	
MATERIAL								SCALE	SHEET
								1:2	1 OF 4

LOC	DIST	REVISIONS			
A	66	REV	DATE	OWN	APVD
-	-	SEE SHEET 1	-	-	-

FEED TYPE MECHANICAL

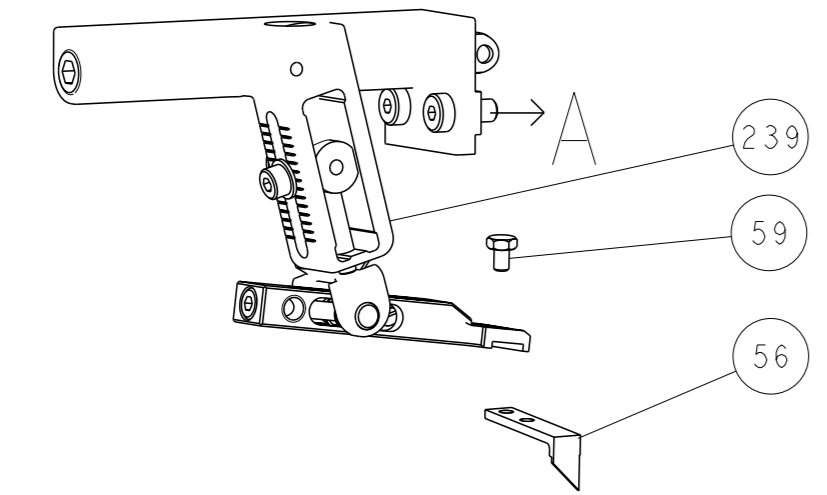

PNEUMATIC

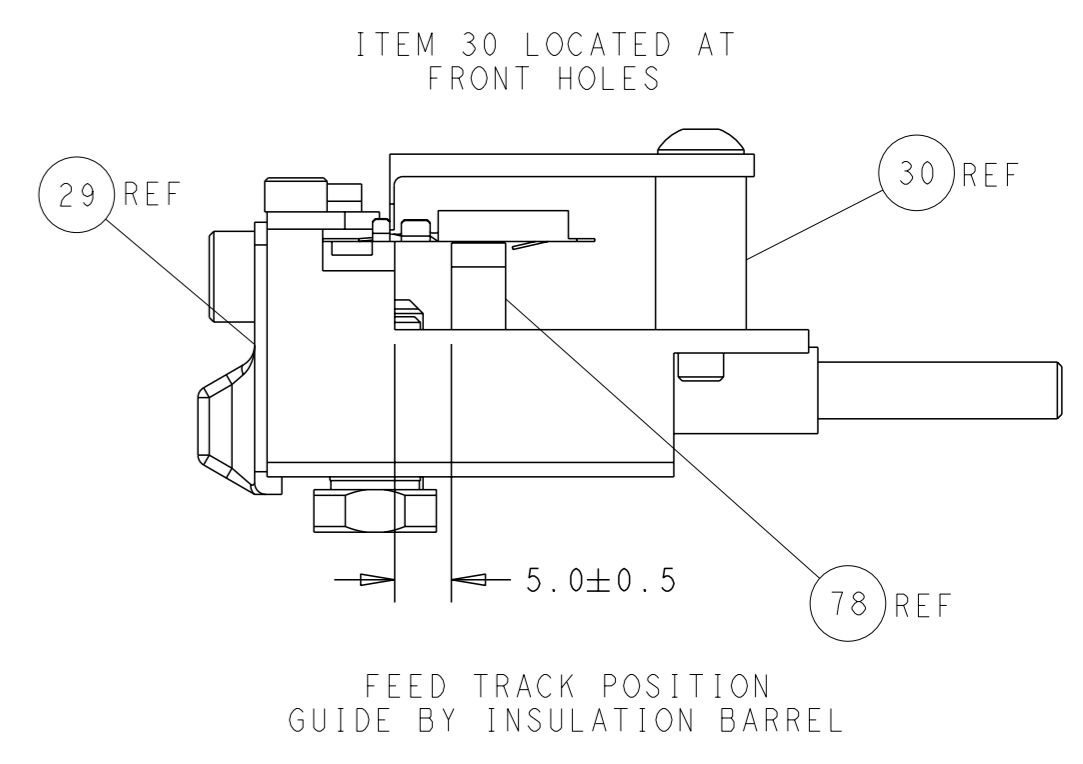
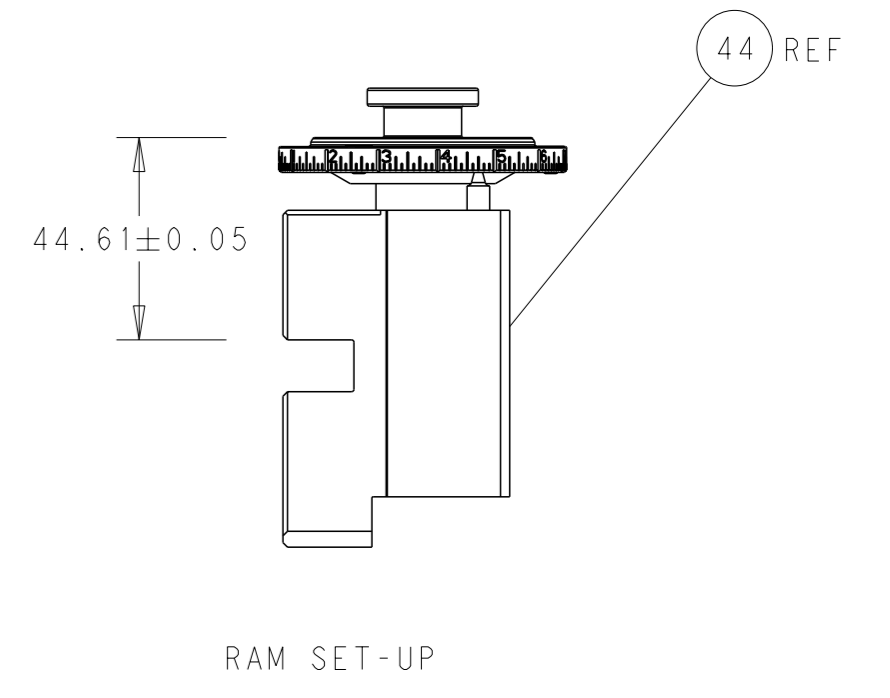
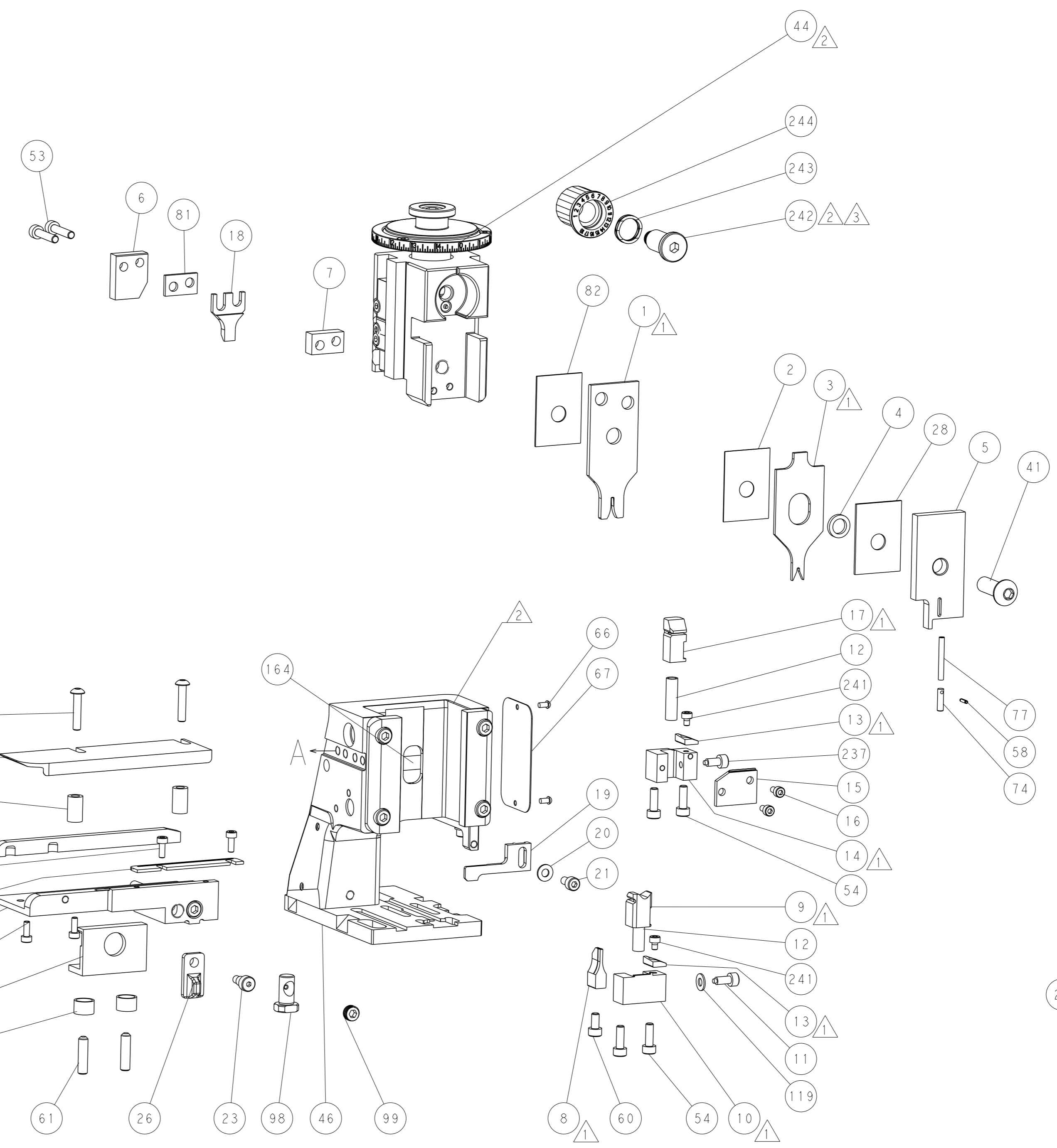
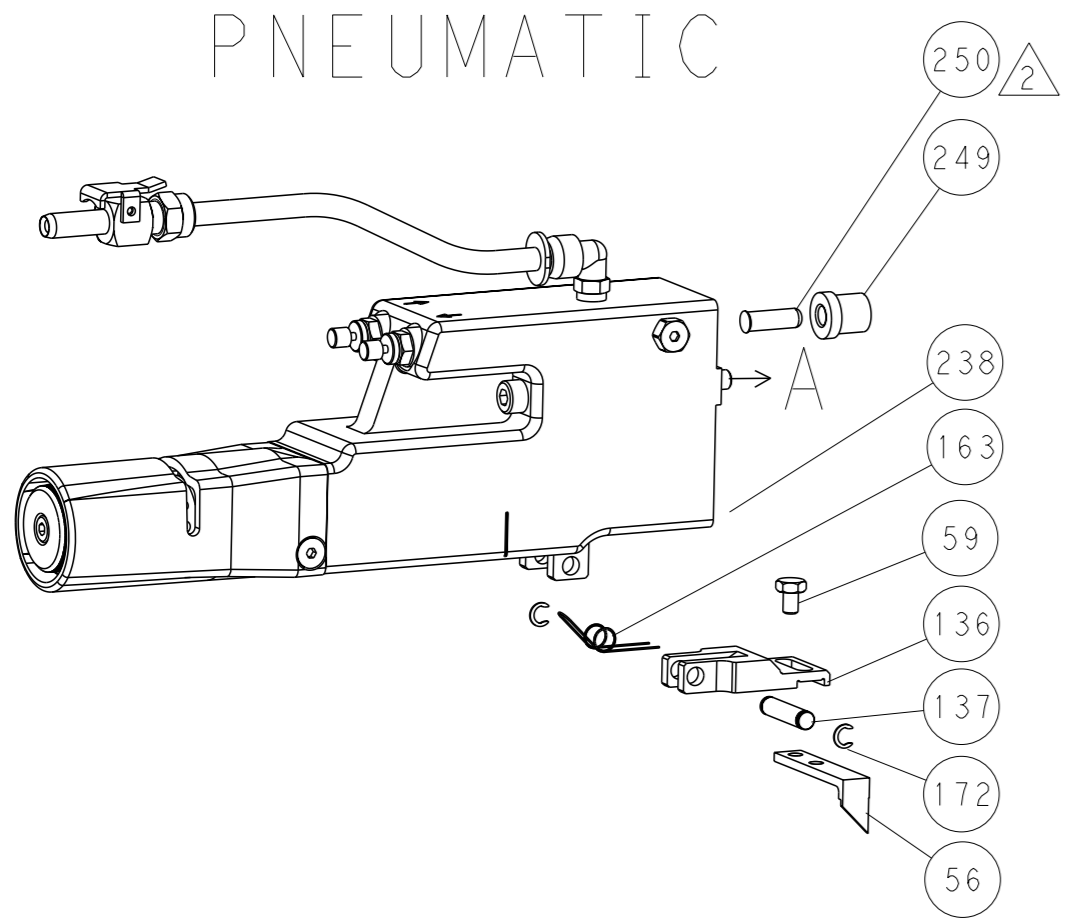

CAM POSITIONS

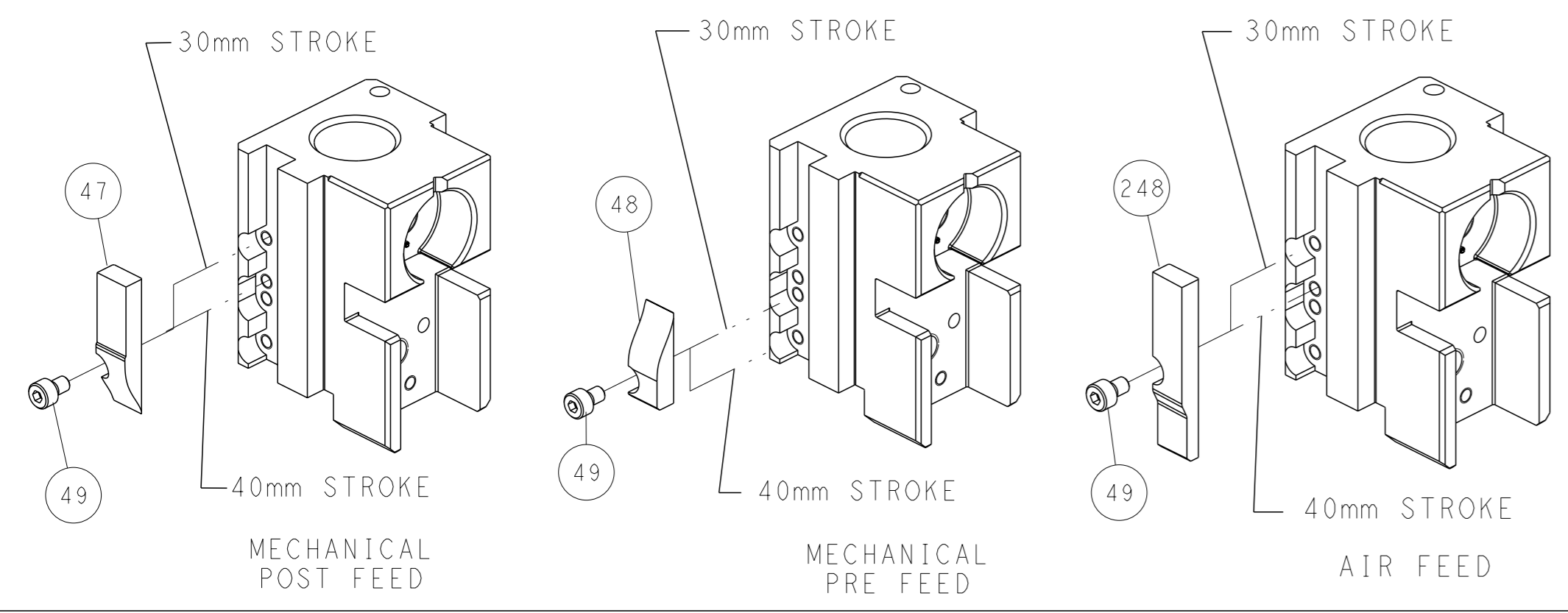

ATLANTIC VERSION
 Shown on sheets 1 of 4 & 2 of 4
 (Pacific version shown on sheets 3 of 4 & 4 of 4)

DIMENSIONS: mm TOLERANCES UNLESS OTHERWISE SPECIFIED: 0 PLC ± 1 PLC ± 2 PLC ± 3 PLC ± 4 PLC ± ANGLES FINISH ±		OWN: H. HUANG 20JUN2013 CHK: L. ZHANG 20JUN2013 APVD: W. GUO 20JUN2013 PRODUCT SPEC APPLICATION SPEC WEIGHT MATERIAL	NAME: Ocean Side Feed Applicator SIZE: A1 CAGE CODE: 00779 DRAWING NO: C=2151985 SCALE: 1:2 SHEET: 2 of 4 REV: C	RESTRICTED TO:
--	--	--	--	----------------

THIS DRAWING IS UNPUBLISHED.	RELEASED FOR PUBLICATION
BY TICO ELECTRONICS CORPORATION. ALL RIGHTS RESERVED.	20
COPYRIGHT 20	

PART NUMBER	REVISION	DESCRIPTION	FEED TYPE
2-2151985-1	C	FINE CRIMP HEIGHT ADJUST	MECHANICAL
2-2151985-2	C	FINE CRIMP HEIGHT ADJUST	PNEUMATIC
7-2151985-7	A	CRIMP TOOLING KIT	-

PACIFIC VERSION TERMINATOR
INTERFACE ADAPTER

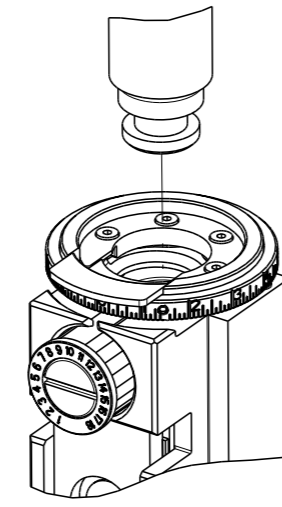

APPLICATOR DATA		
CRIMP	SIZE	TYPE
WIRE	1.40 mm [.055]	F
INSUL	1.57 mm [.062]	O
APPLICATOR INSTRUCTIONS 408-35042		

TERMINAL DATA: TE TERMINAL		TE CRIMP SPECIFICATION	
TERMINAL NAME: CONTACT, TWIN LEAF			
WIRE STRIP LENGTH 3.18-3.96 mm [.125-.156 IN]		INSULATION DIAMETER RANGE Ø1.22-1.52 mm [.048-.060 IN]	
TERMINAL APPLICATION SPECIFICATION	114-9004	-	-
TERMINALS APPLIED			
TE TERMINAL	TE TERMINAL	TE TERMINAL	TE TERMINAL
583853-1	583853-8	1-583853-3	5-583853-3
531477-1	5-531477-2	5-531477-4	

WIRE SIZE	CRIMP HEIGHT mm [INCH]	CRIMP HEIGHT REFERENCE SETTING
20 AWG OR 0.50mm2	1.02 +/- 0.05 [.040 +/- .002]	5.2
0.35mm2	0.92 +/- 0.05 [.036 +/- .002]	6.4
22 AWG OR 0.30mm2	0.92 +/- 0.05 [.036 +/- .002]	6.4
0.25mm2	0.86 +/- 0.05 [.034 +/- .002]	7.0
24 AWG OR 0.20mm2	0.84 +/- 0.05 [.033 +/- .002]	7.2

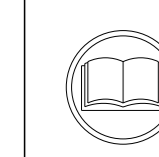

- 1 RECOMMENDED SPARE PARTS
- 2 REFER TO SUPPLIED INSTRUCTION SHEET FOR CLEANING, LUBRICATION AND STORAGE OF APPLICATOR.
- 3 APPLY PART NUMBER 2-23419-6 LOCTITE TO THREADS OF ITEM 242.
- 4 CRIMP HEIGHT REFERENCE SETTING WAS THE SETTING USED WHEN THE APPLICATOR WAS QUALIFIED AT THE FACTORY. ADJUSTMENT MAY BE NECESSARY WHEN RUNNING APPLICATOR IN THE FIELD.
- 5. UNLESS SPECIFIED OTHERWISE TORQUE VALUES SHALL BE USED PER DOCUMENT, 101-35000.

***WARNING**
ON INSTALLATION, SET WIRE DISC TO CRIMP HEIGHT REFERENCE SETTING FOR LARGEST WIRE SIZE. CRIMP HEIGHT REFERENCE SETTINGS GREATER THAN THE VALUE SHOWN MAY CAUSE DAMAGE TO THE CRIMP TOOLING, REFER TO THE INSTRUCTION SHEET FOR PROPER SETUP AND ADJUSTMENTS.

LOC	DIST	REVISIONS					
A	66	P	LYR	DESCRIPTION	DATE	OWN	APVD
		-	-	SEE SHEET 1	-	-	-

-	1	-	2119640-1	PUSH ROD, AIR FEED	250
-	1	-	1803259-1	BUSHING, FLANGED	249
-	1	1	2119082-9	CAM, SNAIL, INSULATION ADJUSTMENT	244
-	1	1	2079764-1	WASHER, WAVE SPRING, CREST-TO-CREST	243
-	1	1	2119083-1	RETAINER, INSULATION DIAL	242
-	2	2	7-18023-7	SCR, SKT HD CAP M3 X 4.0	241
-	-	1	2119580-1	MECHANICAL FEED ASSEMBLY	239
-	1	-	2063440-1	AIR FEED MODULE	238
-	1	1	356885-4	STOP, SHEAR	237
-	2	-	21045-3	RING, RETAIN, EXTERN, 3/16 CRESCENT	172
-	REF	REF	994970-2	COUNTER, MAGNETIC	164
-	1	-	240638-1	SPRING, FEED FINGER	163
-	1	-	2119641-2	FEED CAM, AIR FEED	151
-	1	1	2168083-8	SCR, SKT HD CAP, RoHS, M4 X 16	144
-	4	4	2168083-9	SCR, SKT HD CAP, RoHS, M4 X 20	143
-	-	1	2119653-2	FEED CAM, POST FEED	142
-	1	1	1-1803583-0	APPLICATOR BASIC ASSEMBLY, SF	141
-	1	1	1803516-1	RAM ASSEMBLY, SF PACIFIC	140
-	1	-	3-23627-7	PIN, RETAIN, GRVD, 3/16 X .854	137
-	1	-	2119799-1	HOLDER, FEED FINGER, AF	136
-	1	1	1-18028-2	WASHER, FLAT, REG M4	119
-	1	1	2844908-1	SCREW, LOCKING	99
-	1	1	2844907-1	POST, LOCKING	98
-	1	1	1-690438-0	FRONT STRIP GUIDE	96
-	2	2	2168083-1	SCR, SKT HD CAP, RoHS, M3 X 8.0	95
-	1	1	455888-7	SPACER, CRIMPER	82
-	1	1	1-240641-3	SPACER	81
-	1	1	1633782-2	FENCE	78
-	1	1	5-547505-2	SPRING, COMPRESSION	77
-	2	2	2168083-1	SCR, SKT HD CAP, RoHS, M3 X 8.0	77
-	1	1	854769-4	HOLDER, INS	74
-	1	1	1803607-1	DOCUMENTATION PACKAGE	71
-	1	1	2119740-1	TAG, IDENTIFICATION	67
-	2	2	2168078-1	SCREW, DRIVE, RH, RoHS, 2 x .188	66
-	2	2	2-18032-5	SCR, SET, FLT PNT, M5 X 20.0	61
-	1	1	5-18022-5	SCR, HEX HD CAP, M4 X 6.0	59
-	1	1	21028-2	PIN, SLOTTED SPRING .062 X .250	58
-	1	1	1338685-1	PAWL, FEED	56
-	2	2	2168083-9	SCR, SKT HD CAP, RoHS, M4 X 20	53
-	1	2	18023-9	SCR, SKT HD CAP M4 X 6.0	49
-	-	1	2119652-1	FEED CAM, PRE FEED	48
-	1	1	1803602-1	SCR, BHSC, RoHS (M8 X 25)	41
-	2	2	2079383-5	SCR, BHSC, RoHS (M4 X 20)	33
-	2	2	2-2844962-3	SPACER, CYLINDRICAL, STRIP GUIDE	30
-	1	1	2844992-3	ASSEMBLY, STRIP GUIDE	29
-	1	1	1-455888-0	SPACER, CRIMPER	28
-	2	2	22283-1	SPRING, COMPRESSION	27
-	1	1	356835-1	LEVER, DRAG RELEASE	26
-	1	1	240792-1	DRAG, TERMINAL	25
-	1	1	1320928-2	STRIP GUIDE	24
-	1	1	980371-4	SCR, SKT HD SHLDR 5.0 DIA X 6.0	23
-	1	1	2168083-2	SCR, SKT HD CAP, RoHS, M4 X 8.0	21
-	1	1	1-18028-2	WASHER, FLAT, REG M4	20
-	1	1	2119533-1	STRIPPER, SIDE FEED	19
-	1	1	1-690518-9	HOLD DOWN, TERMINAL	18
-	1	1	690463-1	FLOATING SHEAR, REAR	17
-	2	2	1-2168083-1	SCR, SKT HD CAP, RoHS, M3 X 6	16
-	1	1	690691-9	PLATE, REAR SHEAR	15
-	1	1	2119862-1	SHEAR HOLDER, REAR	14
-	2	2	2119806-1	INSERT, SHEAR	13
-	2	2	3-22280-3	SPRING, COMPRESSION	12
-	1	1	1-356885-4	STOP, SHEAR	11
-	1	1	2119805-1	SHEAR HOLDER, FRONT	10
-	1	1	1803095-1	FLOATING SHEAR, FRONT	9
-	1	1	2-1333201-8	ANVIL, COMBINATION	8
-	1	1	2-240641-2	SPACER	7
-	1	1	690468-1	DEPRESSOR SHEAR, REAR	6
-	1	1	2119780-5	DEPRESSOR, SHEAR	5
-	1	1	2-238011-2	BLOCK, CRIMPER SPACER	4
-	1	1	1633966-6	CRIMPER, INSULATION O	3
-	1	1	455888-4	SPACER, CRIMPER	2
-	1	1	2-456402-6	CRIMPER, WIRE PREMIUM	1

PACIFIC VERSION
Shown on sheets 3 of 4 & 4 of 4
(Atlantic version shown on sheets 1 of 4 & 2 of 4)

DIMENSIONS:		TOLERANCES UNLESS OTHERWISE SPECIFIED:		OWN: H. HUANG 20JUN2013		CHK: L. ZHANG 20JUN2013		APVD: H. GUO 20JUN2013		NAME: Ocean Side Feed Applicator	
mm	0 PLC ±	1 PLC ±	2 PLC ±	3 PLC ±	4 PLC ±	ANGLES	FINISH	WEIGHT	SCALE: 1:2	SHEET 3 OF 4	REV C
MATERIAL:		FINISH:		CAGE CODE: A1 00779		DRAWING NO: ©=2151985		RESTRICTED TO:		Customer Accessible Production Drawing	

