

PART NUMBER	REVISION	DESCRIPTION	FEED TYPE
2150079-2	D	FINE CRIMP HEIGHT ADJUST	PNEUMATIC
7-2150079-2	D	PNEUMATIC AND CRIMP TOOLING KIT	PNEUMATIC
7-2150079-7	C	CRIMP TOOLING KIT	-

ATLANTIC VERSION TERMINATOR INTERFACE ADAPTER

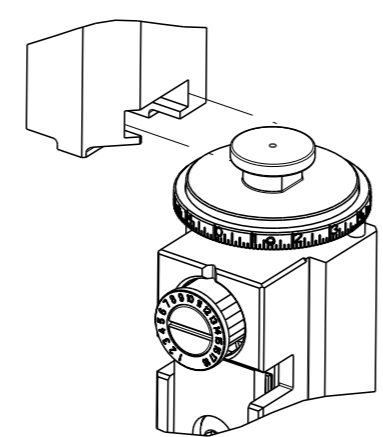

APPLICATOR DATA		
CRIMP	SIZE	TYPE
WIRE	2.54 mm [.100]	F
INSUL	3.56 mm [.140]	F
APPL INSTRUCTIONS 408-35043		

TERMINAL DATA: TE TERMINAL		TE CRIMP SPECIFICATION	
TERMINAL NAME: RECEPTACLESHUR PLUG, .180 DIA			
WIRE STRIP LENGTH		INSULATION DIAMETER RANGE	
3.66-4.26 mm [.144-.168 IN]		∅2.29-3.18 mm [.090-.125 IN]	
TERMINAL APPLICATION SPECIFICATION	114-2017		
TERMINALS APPLIED			
TE TERMINAL	TE TERMINAL	TE TERMINAL	TE TERMINAL
60798-2	60798-4	60798-6	60799-2
60799-4	60799-5		

WIRE SIZE	CRIMP HEIGHT mm [INCH]	CRIMP HEIGHT REFERENCE SETTING
14 AWG	1.96 +/- 0.05 [0.077 +/- .002]	5.3
16 AWG	1.70 +/- 0.05 [0.067 +/- .002]	8.5
18 AWG	1.55 +/- 0.05 [0.061 +/- .002]	9.9

- RECOMMENDED SPARE PARTS
- REFER TO SUPPLIED INSTRUCTION SHEET FOR CLEANING, LUBRICATION AND STORAGE OF APPLICATOR.
- APPLY PART NUMBER 2-23419-6 LOCTITE TO THREADS OF ITEM 242. APPLY PART NUMBER 1-23419-5 LOCTITE TO THREADS OF ITEM 180.
- CRIMP HEIGHT REFERENCE SETTING WAS THE SETTING USED WHEN THE APPLICATOR WAS QUALIFIED AT THE FACTORY. ADJUSTMENT MAY BE NECESSARY WHEN RUNNING APPLICATOR IN THE FIELD.
- TERMINAL LUBRICANT IS RECOMMENDED.
- 6. UNLESS SPECIFIED OTHERWISE TORQUE VALUES SHALL BE USED PER DOCUMENT, 101-35000.
- TERMINAL PITCH NOT COMPATIBLE WITH MECHANICAL FEED.

***WARNING**
ON INSTALLATION, SET WIRE DISC TO CRIMP HEIGHT REFERENCE SETTING FOR LARGEST WIRE SIZE. CRIMP HEIGHT REFERENCE SETTINGS GREATER THAN THE VALUE SHOWN MAY CAUSE DAMAGE TO THE CRIMP TOOLING. REFER TO THE INSTRUCTION SHEET FOR PROPER SETUP AND ADJUSTMENTS.

LOC	DIST	REVISIONS					
		#	LYR	DESCRIPTION	DATE	OWN	APVD
A	66	A		RELEASED	15JUL2014	JH	TE
		B		ECR-18-015161	23SEP2018	TB	TE
		C		ECR-19-004651	22MAR2019	TB	GB
		D		ECR-19-008437	03JUN2019	LG	TE

-	1	1	2119641-1	FEED CAM, AIR FEED	248	
-	1	1	2119082-8	CAM, SNAIL, INSULATION ADJUSTMENT	244	
-	1	1	2079764-1	WASHER, WAVE SPRING, CREST-TO-CREST	243	
	-	-	2119083-1	RETAINER, INSULATION DIAL	242	
-	-	-	2119580-1	MECHANICAL FEED ASSEMBLY	239	
-	1	1	2844940-3	AIR FEED MODULE	238	
-	1	1	1-18028-0	WASHER, FLAT, REG M8	192	
	-	1	2-1752354-0	STANDOFF, HOLD-DOWN	180	
-	1	1	6-9931111-6	PIN, SLOTTED SPRING 3.0 X 14.0	177	
-	1	1	8-22280-7	SPRING, COMPRESSION	176	
-	1	1	1752353-2	GUIDE PIN, HOLDDOWN	175	
-	1	1	1901680-2	GUIDE PIN, HOLDDOWN	174	
-	REF	REF	994970-2	COUNTER, MAGNETIC	164	
	-	1	2119955-2	ASSY, LUBRICATOR, END FEED	84	
-	1	1	455888-5	SPACER, CRIMPER	82	
-	1	1	1803607-4	DOCUMENTATION PACKAGE	71	
-	2	2	2-18032-2	SCR, SET, FLT PNT, M3 X 10.0	70	
-	1	1	2119740-1	TAG, IDENTIFICATION	67	
-	2	2	2168078-1	SCREW, DRIVE, RH, RoHS, 2 x .188	66	
-	1	1	1901681-1	HOLDDOWN, TERMINAL	65	
-	2	2	2168400-5	SHCS, LOW HEAD, RoHS, M4 X 20	64	
-	1	1	2168083-2	SCR, SKT HD CAP, RoHS, M4 X 8.0	60	
-	1	1	5-18022-5	SCR, HEX HD CAP, M4 X 6.0	59	
-	3	3	2168400-4	SHCS, LOW HEAD, RoHS, M4 X 8	57	
-	2	2	2-2168083-5	SCR, SKT HD CAP, RoHS, M4 X 14	56	
-	2	2	5018030-1	NUT, HEX, REG, RoHS, M3	54	
-	2	2	986965-8	NUT, LOCK, HEX, TORQUE (M4)	53	
-	1	1	1-5018030-0	NUT, HEX, REG, RoHS, M3.5	52	
-	1	1	2063961-1	FEED FINGER	51	
-	1	1	18023-9	SCR, SKT HD CAP M4 X 6.0	49	
-	1	1	2119655-5	APPLICATOR BASIC ASSEMBLY, EF	46	
-	1	1	1803517-1	RAM ASSEMBLY, EF ATLANTIC	44	
-	1	1	1803602-1	SCR, BHSC, RoHS (M8 X 25)	41	
-	7	7	1-18028-2	WASHER, FLAT, REG M4	33	
-	2	2	2168083-9	SCR, SKT HD CAP, RoHS, M4 X 20	31	
-	2	2	2168083-2	SCR, SKT HD CAP, RoHS, M4 X 8.0	29	
-	1	1	240639-1	STRIPPER (MACHINING)	27	
-	2	2	1-2168083-5	SCR, SKT HD CAP, RoHS, M4 X 30	25	
-	1	1	1752371-5	PLATE, STRIP GUIDE	24	
-	1	1	240825-3	PLATE, STRIP HOLD DOWN	23	
-	2	2	2-22281-3	SPRING, COMPRESSION	22	
-	1	1	1803292-4	DRAG	20	
-	2	2	1901259-6	GUIDE, LOWER STRIP	18	
-	4	4	1-2079383-1	SCR, BHSC, RoHS (M6 X 12)	17	
-	1	1	2-240641-9	SPACER	16	
-	1	1	1752360-1	SPACER, HOLD-DOWN	13	
	-	1	240644-1	PLATE, REAR SHEAR	11	
	-	2	1-240645-1	SPACER, SHEAR PLATE	10	
	-	1	240642-8	PLATE, FRONT SHEAR	9	
	1	2	1	5-1803000-3	ANVIL, COMBINATION, END FEED	8
	-	1	1	8-240651-7	BLADE, SLUG	7
-	-	-	-	-	6	
-	1	1	240641-8	SPACER	5	
-	1	1	238011-2	BLOCK, CRIMPER SPACER	4	
	1	2	1	2-1633961-3	CRIMPER, INSULATION F PREMIUM	3
-	1	1	455888-8	SPACER, CRIMPER	2	
	1	2	1	2-1633860-4	CRIMPER, WIRE	1
-	77	72	-2	PART NO		
-				DESCRIPTION	ITEM NO	

ATLANTIC VERSION
Shown on sheets 1 of 4 & 2 of 4
(Pacific version shown on sheets 3 of 4 & 4 of 4)

DIMENSIONS:		TOLERANCES UNLESS OTHERWISE SPECIFIED:		OWN		NAME	
mm	0 PLC ±	1 PLC ±	2 PLC ±	J. HOU	27MAY2014	STE TE Connectivity Harrisburg, PA 17105-3608	
	3 PLC ±	4 PLC ±	ANGLES ±	Y. YIN	27MAY2014	Ocean End Feed Applicator	
MATERIAL	FINISH	WEIGHT	SCALE	APVD	U. GUO	00779	2150079
			1:1	Customer Accessible Production Drawing		1	4

LOC	DIST	REVISIONS			
		REV	DATE	OWN	APVD
A	66	-	SEE SHEET 1	-	-

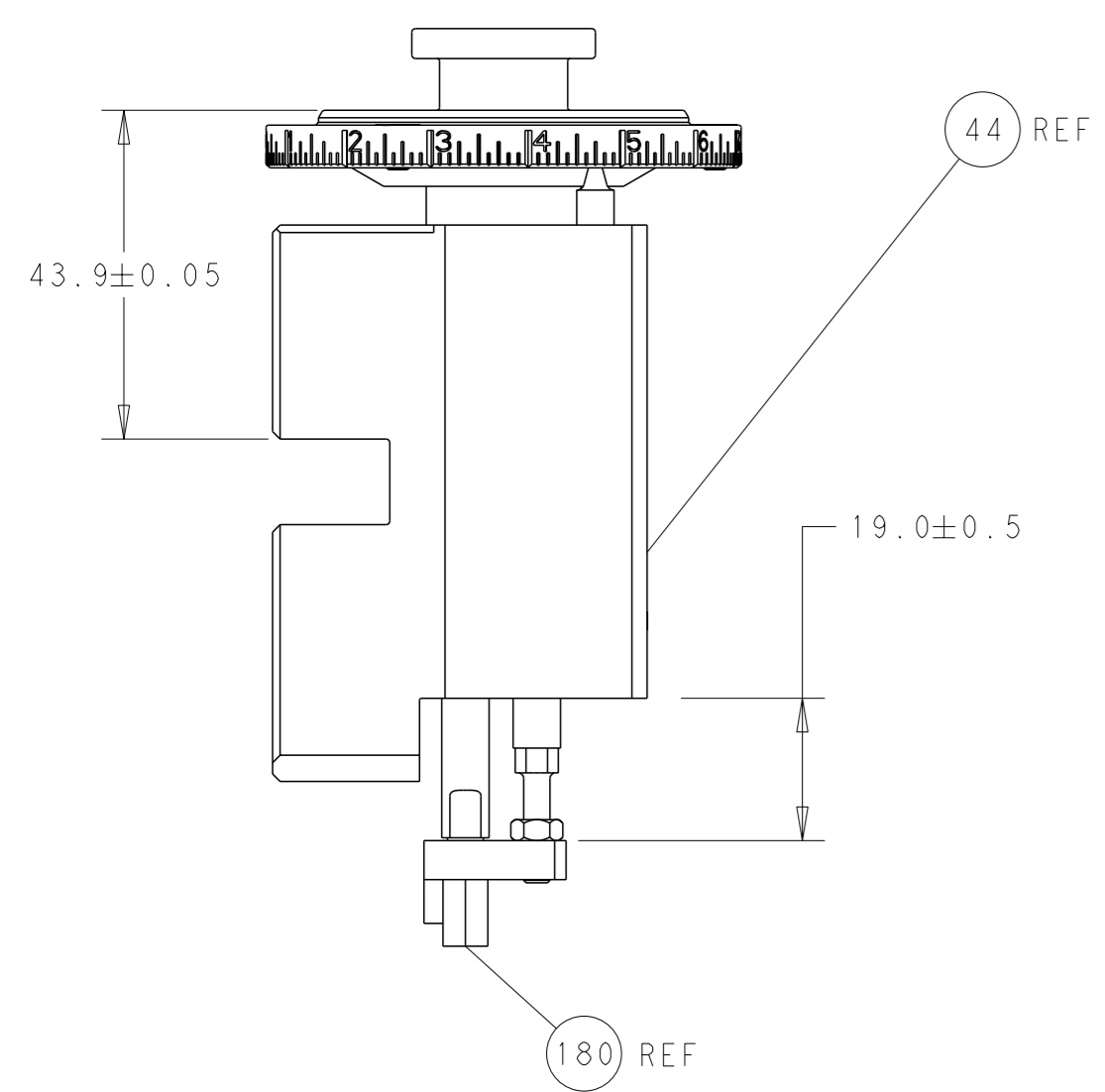

RAM AND HOLDDOWN SET-UP

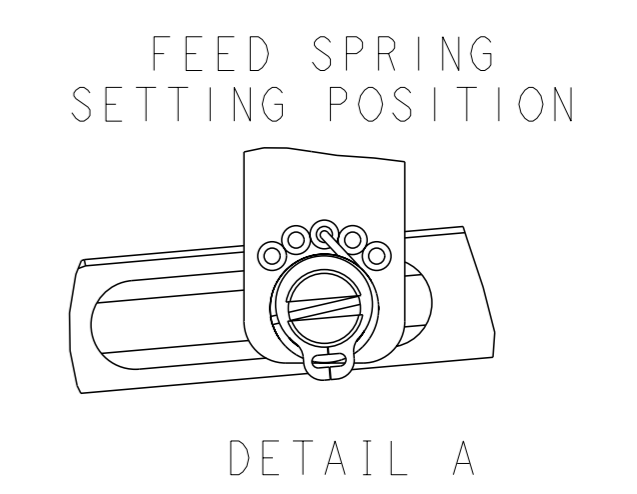
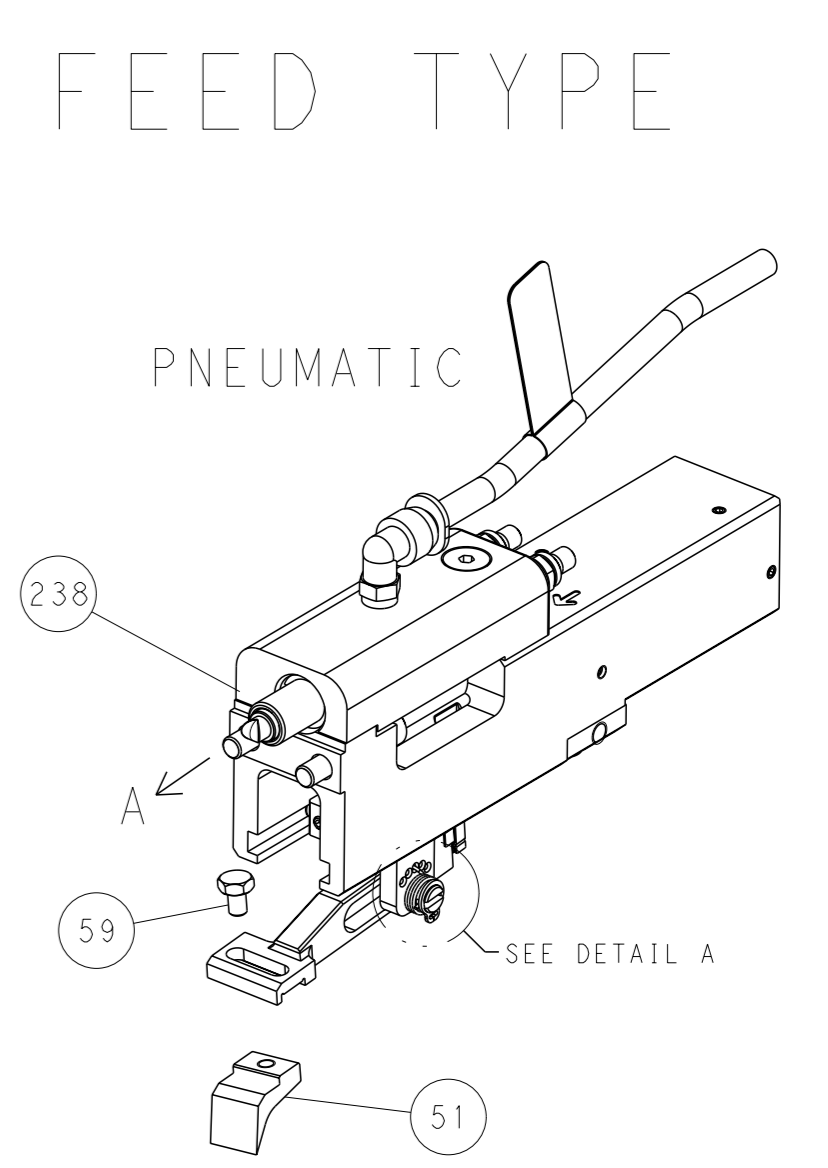
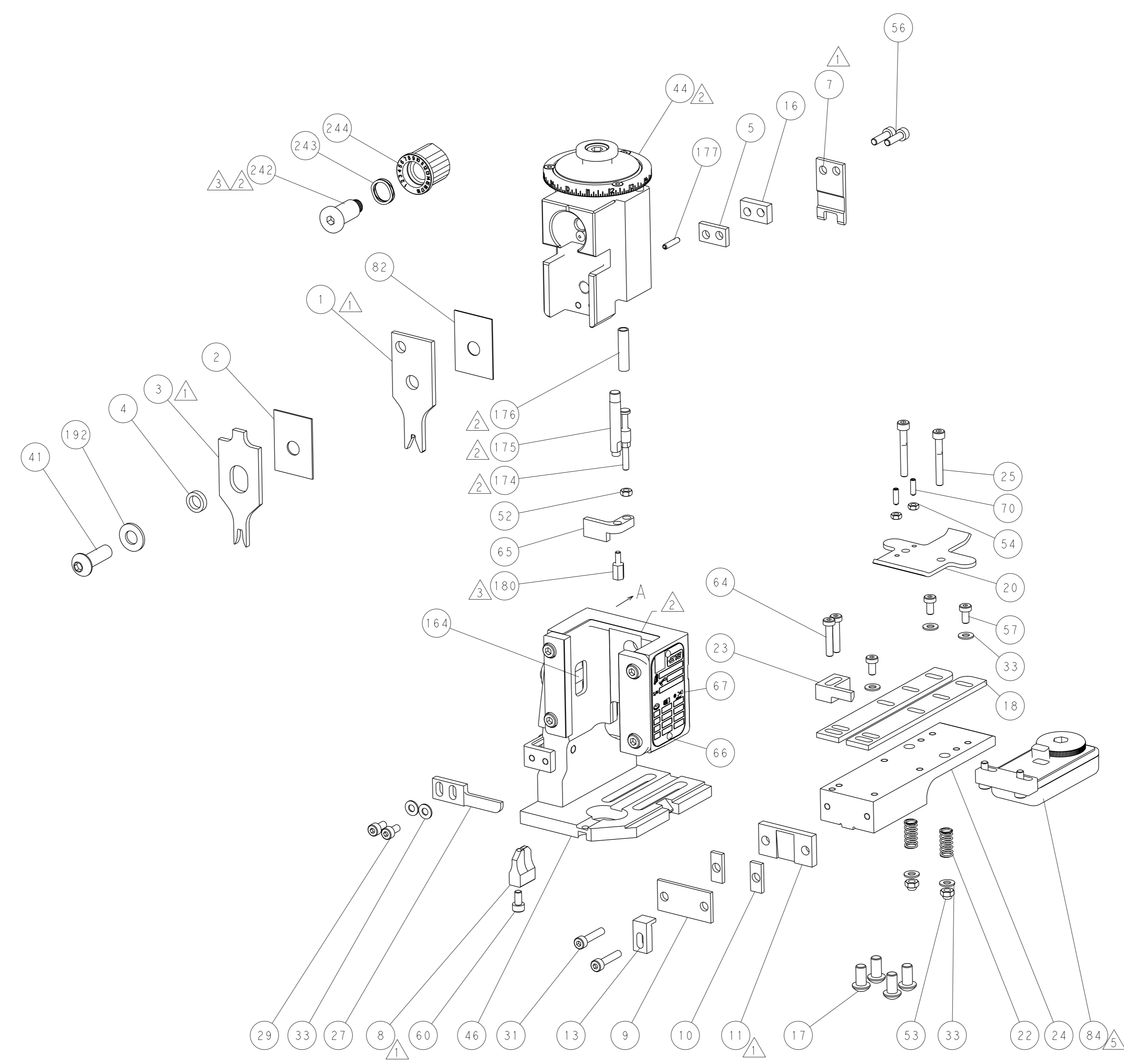

CAM POSITION

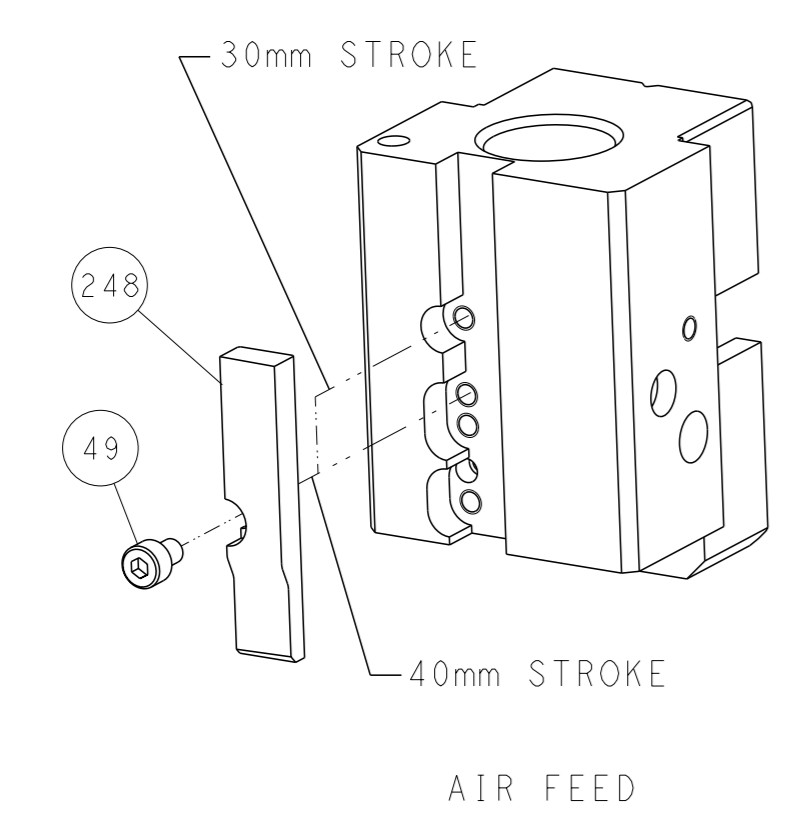

ATLANTIC VERSION
 Shown on sheets 1 of 4 & 2 of 4
 (Pacific version shown on sheets 3 of 4 & 4 of 4)

<small>THIS DRAWING IS A CONTROLLED DOCUMENT FOR TYCO ELECTRONICS CORPORATION. IT IS SUBJECT TO CHANGE AND TO CONTROLING ENGINEERING DISCRETION. SHOULD BE CONTACTED FOR THE LATEST REVISION.</small>		DWN J. HOW 27MAY2014 CHK Y. YIN 27MAY2014 APVD U. GUO 27MAY2014	TE Connectivity Harrisburg, PA 17105-3608
DIMENSIONS: mm 		TOLERANCES UNLESS OTHERWISE SPECIFIED: 0 PLC ± 1 PLC ± 2 PLC ± 3 PLC ± 4 PLC ± ANGLES FINISH ±	NAME Ocean End Feed Applicator SIZE CAGE CODE DRAWING NO. RESTRICTED TO A 00779 C=2150079
MATERIAL:		WEIGHT:	Customer Accessible Production Drawing SCALE 1:1 SHEET 2 of 4 REV D

THIS DRAWING IS UNPUBLISHED.	RELEASED FOR PUBLICATION	20	
COPYRIGHT 20 BY TYCO ELECTRONICS CORPORATION. ALL RIGHTS RESERVED.			
PART NUMBER	REVISION	DESCRIPTION	FEED TYPE
2-2150079-2	D	FINE CRIMP HEIGHT ADJUST	PNEUMATIC
7-2150079-7	C	CRIMP TOOLING KIT	-

PACIFIC VERSION TERMINATOR
INTERFACE ADAPTER

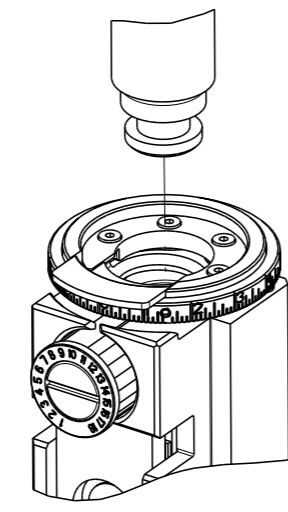

APPLICATOR DATA		
CRIMP	SIZE	TYPE
WIRE	2.54 mm [.100]	F
INSUL	3.56 mm [.140]	F
APPL INSTRUCTIONS 408-35043		

TERMINAL DATA: TE TERMINAL				TE CRIMP SPECIFICATION			
TERMINAL NAME: RECEPTACLESHUR PLUG, .180 DIA							
WIRE STRIP LENGTH 3.66-4.26 mm [.144-.168 IN]				INSULATION DIAMETER RANGE Ø2.29-3.18 mm [.090-.125 IN]			
TERMINAL APPLICATION SPECIFICATION 114-2017							
TERMINALS APPLIED							
TE TERMINAL	TE TERMINAL	TE TERMINAL	TE TERMINAL	TE TERMINAL	TE TERMINAL	TE TERMINAL	TE TERMINAL
60798-2	60798-4	60798-6	60799-2	60799-4	60799-5		

WIRE SIZE	CRIMP HEIGHT mm [INCH]	CRIMP HEIGHT REFERENCE SETTING
14 AWG	1.96+/-0.05 [.077+/-0.002]	5.3
16 AWG	1.70+/-0.05 [.067+/-0.002]	8.5
18 AWG	1.55+/-0.05 [.061+/-0.002]	9.9

***WARNING**
ON INSTALLATION, SET WIRE DISC TO CRIMP HEIGHT REFERENCE SETTING FOR LARGEST WIRE SIZE. CRIMP HEIGHT REFERENCE SETTINGS GREATER THAN THE VALUE SHOWN MAY CAUSE DAMAGE TO THE CRIMP TOOLING. REFER TO THE INSTRUCTION SHEET FOR PROPER SETUP AND ADJUSTMENTS.

- RECOMMENDED SPARE PARTS
- REFER TO SUPPLIED INSTRUCTION SHEET FOR CLEANING, LUBRICATION AND STORAGE OF APPLICATOR.
- APPLY PART NUMBER 2-23419-6 LOCTITE TO THREADS OF ITEM 242. APPLY PART NUMBER 1-23419-5 LOCTITE TO THREADS OF ITEM 180.
- CRIMP HEIGHT REFERENCE SETTING WAS THE SETTING USED WHEN THE APPLICATOR WAS QUALIFIED AT THE FACTORY. ADJUSTMENT MAY BE NECESSARY WHEN RUNNING APPLICATOR IN THE FIELD.
- TERMINAL LUBRICANT IS RECOMMENDED.
- UNLESS SPECIFIED OTHERWISE TORQUE VALUES SHALL BE USED PER DOCUMENT, 101-35000.
- TERMINAL PITCH NOT COMPATIBLE WITH MECHANICAL FEED.

LOC	DIST	REVISIONS					
A	66	P	LY#	DESCRIPTION	DATE	OWN	APVD
		-		SEE SHEET 1	-	-	-

-	1	2119082-8	CAM, SNAIL, INSULATION ADJUSTMENT	244	
-	1	2079764-1	WASHER, WAVE SPRING, CREST-TO-CREST	243	
3	-	2119083-1	RETAINER, INSULATION DIAL	242	
-	-	2119580-1	MECHANICAL FEED ASSEMBLY	239	
-	1	2844940-3	AIR FEED MODULE	238	
-	1	1-18028-0	WASHER, FLAT, REG M8	192	
-	4	2079383-9	SCR, BHSC, RoHS (M6 X 20)	186	
3	-	2-1752354-0	STANDOFF, HOLD-DOWN	180	
-	1	6-9931111-6	PIN, SLOTTED SPRING 3.0 X 14.0	177	
-	1	8-22280-7	SPRING, COMPRESSION	176	
-	1	1752353-2	GUIDE PIN, HOLDDOWN	175	
-	1	1901680-2	GUIDE PIN, HOLDDOWN	174	
-	REF	994970-2	COUNTER, MAGNETIC	164	
-	1	2119641-2	FEED CAM, AIR FEED	152	
-	1	2168083-8	SCR, SKT HD CAP, RoHS, M4 X 16	144	
-	1	2119656-6	APPLICATOR BASIC ASSEMBLY, EF	141	
-	1	1803518-1	RAM ASSEMBLY, EF PACIFIC	140	
5	-	2119955-2	ASSY, LUBRICATOR, END FEED	84	
-	1	455888-5	SPACER, CRIMPER	82	
-	1	1803607-4	DOCUMENTATION PACKAGE	71	
-	2	2-18032-2	SCR, SET, FLT PNT, M3 X 10.0	70	
-	1	2119740-1	TAG, IDENTIFICATION	67	
-	2	2168078-1	SCREW, DRIVE, RH, RoHS, 2 x .188	66	
-	1	1901681-1	HOLDDOWN, TERMINAL	65	
-	2	2168400-5	SHCS, LOW HEAD, RoHS, M4 X 20	64	
-	1	5-18022-5	SCR, HEX HD CAP, M4 X 6.0	59	
-	3	2168400-4	SHCS, LOW HEAD, RoHS, M4 X 8	57	
-	2	2-2168083-5	SCR, SKT HD CAP, RoHS, M4 X 14	56	
-	2	5018030-1	NUT, HEX, REG, RoHS, M3	54	
-	2	986965-8	NUT, LOCK, HEX, TORQUE (M4)	53	
-	1	1-5018030-0	NUT, HEX, REG, RoHS, M3.5	52	
-	1	2063961-1	FEED FINGER	51	
-	1	18023-9	SCR, SKT HD CAP M4 X 6.0	49	
-	1	1803602-1	SCR, BHSC, RoHS (M8 X 25)	41	
-	7	1-18028-2	WASHER, FLAT, REG M4	33	
-	2	2168083-9	SCR, SKT HD CAP, RoHS, M4 X 20	31	
-	2	2168083-2	SCR, SKT HD CAP, RoHS, M4 X 8.0	29	
-	1	240639-1	STRIPPER (MACHINING)	27	
-	2	1-2168083-5	SCR, SKT HD CAP, RoHS, M4 X 30	25	
-	1	1752371-5	PLATE, STRIP GUIDE	24	
-	1	240825-3	PLATE, STRIP HOLD DOWN	23	
-	2	2-22281-3	SPRING, COMPRESSION	22	
-	1	1803292-4	DRAG	20	
-	2	1901259-6	GUIDE, LOWER STRIP	18	
-	1	2-240641-9	SPACER	16	
-	1	1752360-1	SPACER, HOLD-DOWN	13	
1	-	240644-1	PLATE, REAR SHEAR	11	
-	2	1-240645-1	SPACER, SHEAR PLATE	10	
1	-	240642-8	PLATE, FRONT SHEAR	9	
1	1	5-1803000-3	ANVIL, COMBINATION, END FEED	8	
1	-	8-240651-7	BLADE, SLUG	7	
-	-	-	-	6	
-	1	240641-8	SPACER	5	
-	1	238011-2	BLOCK, CRIMPER SPACER	4	
1	1	2-1633961-3	CRIMPER, INSULATION F PREMIUM	3	
-	1	455888-8	SPACER, CRIMPER	2	
1	1	2-1633860-4	CRIMPER, WIRE	1	
-	-	-77-22	PART NO	DESCRIPTION	ITEM NO

PACIFIC VERSION
Shown on sheets 3 of 4 & 4 of 4
(Atlantic version shown on sheets 1 of 4 & 2 of 4)

DIMENSIONS: mm		TOLERANCES UNLESS OTHERWISE SPECIFIED:		OWN J.HOU 27MAY2014	TE Connectivity
0 PLC ±		1 PLC ±		CHK Y.YIN 27MAY2014	Harrisburg, PA 17105-3608
2 PLC ±		3 PLC ±		APVD U.GUO 27MAY2014	
4 PLC ±		FINISH		NAME	
MATERIAL		WEIGHT		SIZE	Customer Accessible Production Drawing
				CAGE CODE	00779
				DRAWING NO	2150079
				SCALE	1:1
				SHEET	3 of 4
				REV	D

LOC	DIST	REVISIONS			
A	66	REV	DATE	OWN	APVD
		-	SEE SHEET 1	-	-

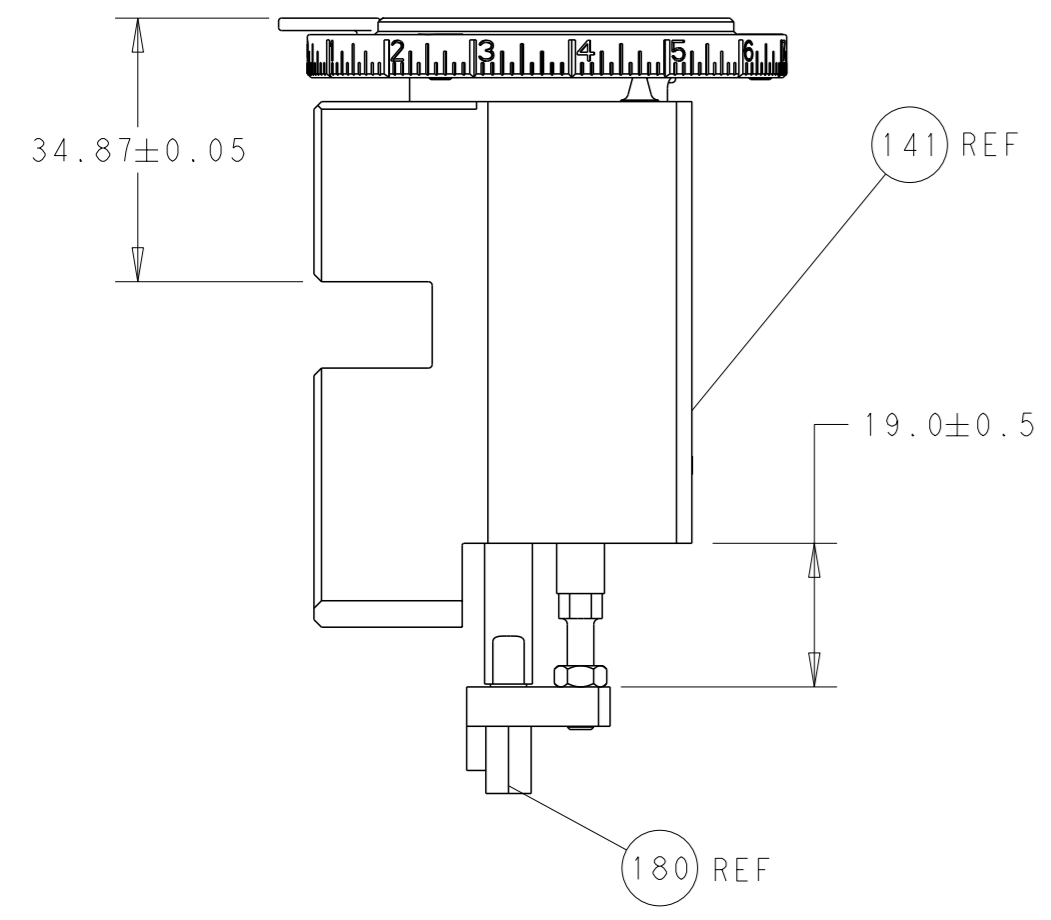

RAM AND HOLDDOWN SET-UP

FEED TYPE

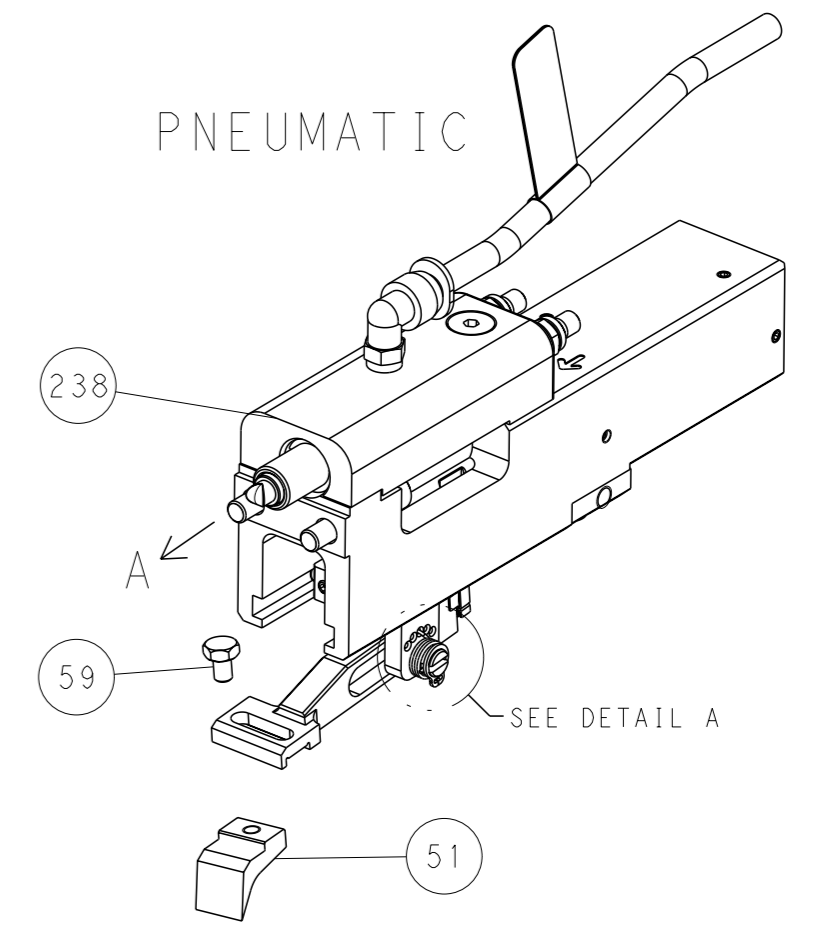

FEED SPRING SETTING POSITION

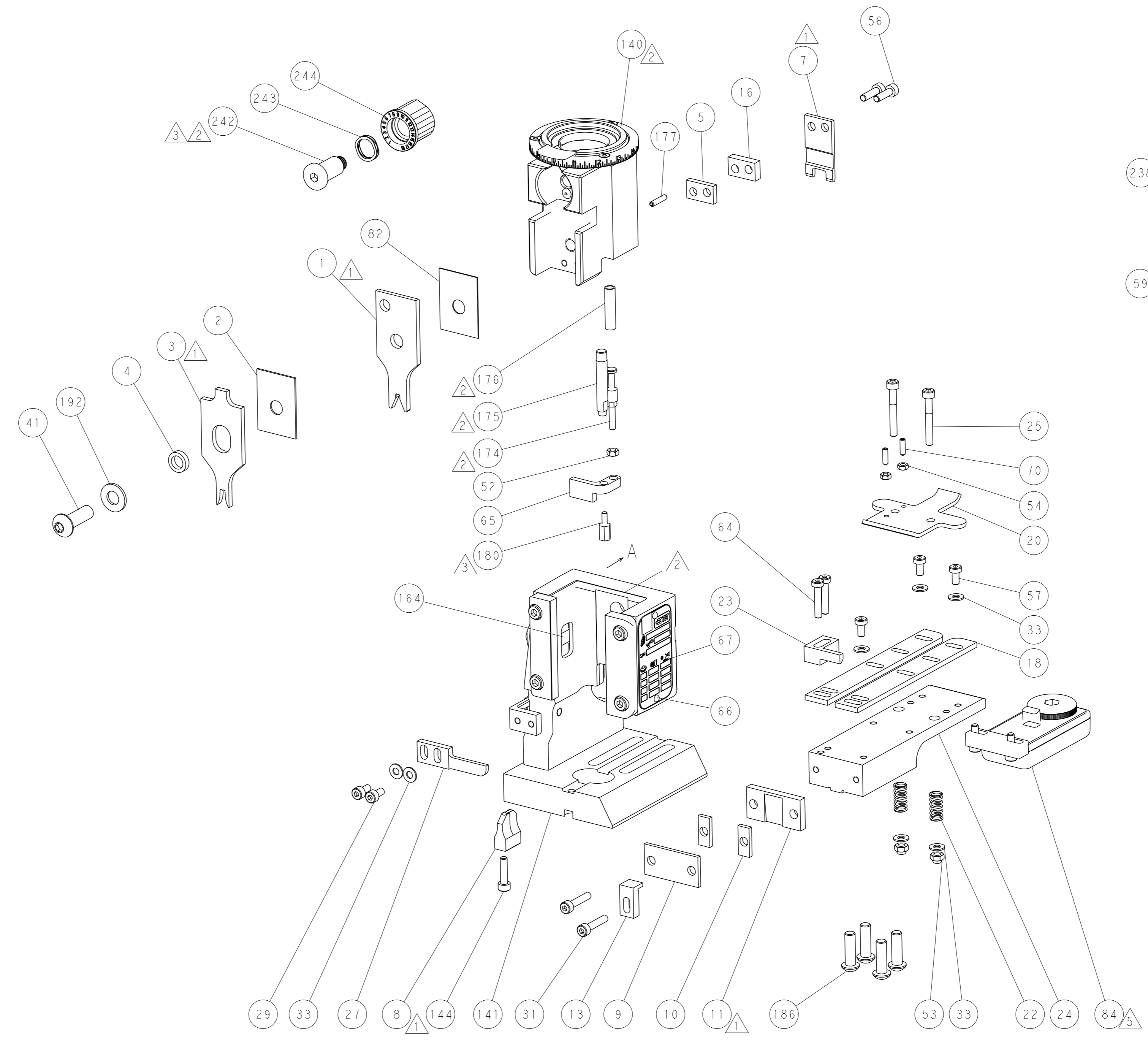
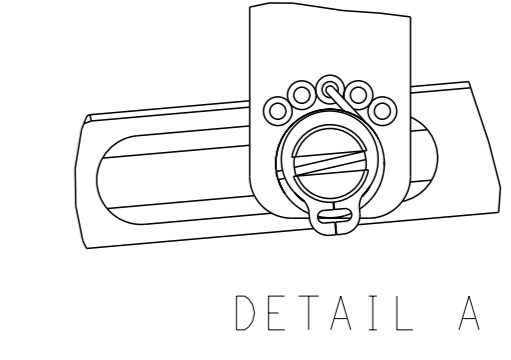

CAM POSITION

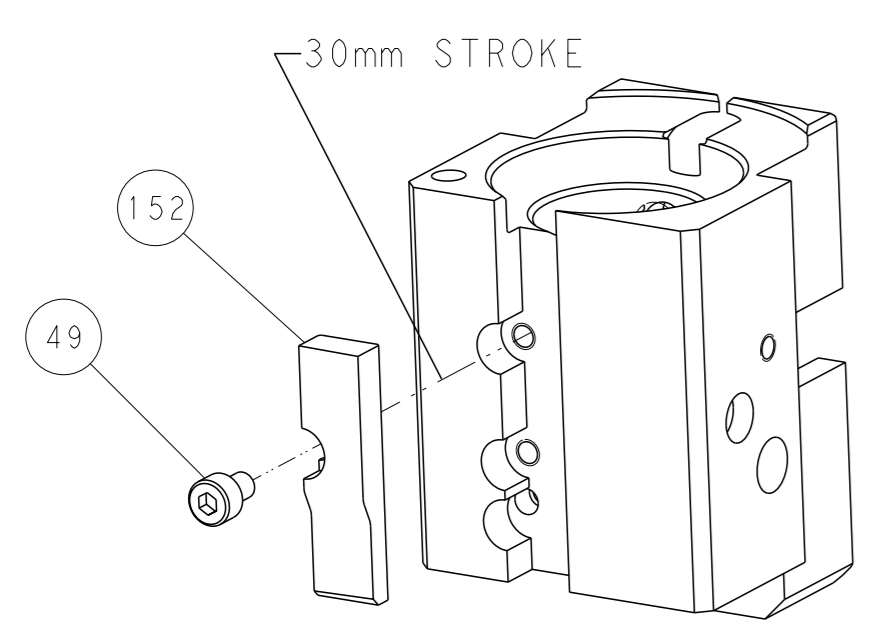

AIR FEED

PACIFIC VERSION
 Shown on sheets 3 of 4 & 4 of 4
 (Atlantic version shown on sheets 1 of 4 & 2 of 4)

<small>THIS DRAWING IS A CONTROLLED DOCUMENT FOR TYCO ELECTRONICS CORPORATION. IT IS SUBJECT TO CHANGE AND THE CONTROLLING ENGINEERING ORGANIZATION SHOULD BE CONTACTED FOR THE LATEST REVISION.</small>		DWN J. HOU 27MAY2014 CHK Y. YIN 27MAY2014 APVD U. GUO 27MAY2014	TE Connectivity Harrisburg, PA 17105-3608
DIMENSIONS: mm TOLERANCES UNLESS OTHERWISE SPECIFIED: 0 PLC ± 1 PLC ± 2 PLC ± 3 PLC ± 4 PLC ± ANGLES FINISH *		NAME Ocean End Feed Applicator SIZE CAGE CODE DRAWING NO. RESTRICTED TO A 00779 C=2150079	WEIGHT - SCALE 1:1 SHEET 4 OF 4 REV D
MATERIAL:		Customer Accessible Production Drawing	