

## SPECIFICATION

- Part No. : **MMB.A.EXTMA**
- Product Name : Torus Magnetic Mount Base For Taoglas External Antennas
- Features : Super Strong Magnets Integrated In The Base for Reliable Installation  
Customizable For Different External Antenna Thread Diameters From Ø16mm to Ø31mm  
No Drilling Required

**MMB.A.EXTMA.16**-- Ø16mm, For Taoglas Olympian Series Application

**MMB.A.EXTMA.19**-- Ø19mm, For Taoglas Hercules Series Application

**MMB.A.EXTMA.21**-- Ø21mm, For Taoglas Spartan ST version & Pantheon ST version Series Application

**MMB.A.EXTMA.31**-- Ø31mm, For Taoglas Ultima, Spartan, & Pantheon Series Application

RoHS Compliant

Photo:



Side View



Top View

**MMB.A.EXTMA.16**-- Ø16mm, For Taoglas Olympian Series Application



**MMB.A.EXTMA.19**-- Ø19mm, For Taoglas Hercules Series Application



**MMB.A.EXTMA.21**-- Ø21mm, For Taoglas Spartan ST version



**MMB.A.EXTMA.21**-- Ø21mm, Pantheon ST version



**MMB.A.EXTMA.31**-- Ø31mm, For Taoglas Ultima Series Application



**MMB.A.EXTMA.31** - Ø31mm, For Taoglas Spartan Series Application



**MMB.A.EXTMA.31** - Ø31mm, For Taoglas Pantheon Series Application



## 1. Introduction

The Taoglas MMB series is a robust magnetic mount base solution for external Taoglas antennas that would typically require drilling a hole for installation. There are times when drilling a hole for installation is not feasible either due to cost or aesthetics. The Taoglas MMB magnetic mount base removes the need to drill by providing an adapter with the proper hole size for the antenna you are using. The MMB series can support various Taoglas external antennas including the Olympian, Hercules, Ultima, Spartan, Spartan ST, Pantheon, and Pantheon ST series.

The MMB can be mounted on iron/steel metal surfaces such as tops of vehicles, containers, etc. Due to six strong magnets, the magnetic force can resist wind speeds over 100KM/H (road test). Under the MMB, there is a soft cushion of foam which can protect the mounting surface during the mounting/removing processes.

There are four standard mounting bases which have different aligning hole diameters from 16mm to 31mm, see table below for model numbers.

Torus Magnetic Base for Screw Mount Antennas			
Part #	Description	Model Thread Ø	Model Numbers
<a href="#">MMB.A.EXTMA.16</a>	Ø16mm, For Taoglas Olympian	12mm	G30, MA140
<a href="#">MMB.A.EXTMA.19</a>	Ø19mm, For Taoglas Hercules	18mm	A.01, A.03, A.40, A.41, G21, IS.01, IS.02, IS.04, IS.05, WS.01, WS.02, MA104, MA106, MA120, MA501, MA510, MA515, MA520
<a href="#">MMB.A.EXTMA.21</a>	Ø21mm, For Taoglas Spartan ST	20mm	MA600.ST, MA612.ST, MA650.ST
	Ø21mm, For Taoglas Pantheon ST		MA700.ST, MA710.ST, MA750.ST, MA760.ST
<a href="#">MMB.A.EXTMA.31</a>	Ø31mm, For Taoglas Ultima	24mm	A.30, G24, MA111, MA530, WS.24
	Ø31mm, For Taoglas Spartan	30mm	MA600, MA602, MA603, MA650, MA660, MA671, MA672, MA673
	Ø31mm, For Taoglas Pantheon		MA700, MA710, MA741, MA750, MA760, MA761, MA770

Each part comes ready assembled – ready for Installation. This magnetic base can be easily adapted to suit customer requirements – customization may be subject to an NRE and a MOQ, please [contact your regional Taoglas Sales Office.](#)

## 2. Specification

MECHANICAL	
Dimension (mm)	Diameter : 178.7, Height : 56
Magnets	6 Magnets integrated in base
Material	ABS
Adapter	Ø16mm, Ø19mm, Ø21mm, Ø31mm, Fully Customizable
Magnetic Pull Force	20 kgF
Weight	560g
ENVIRONMENTAL RATINGS	
Storage Temperature Range	-40°C to +85°C
Operation Temperature Range	-40°C to +85°C
Humidity	Non-condensing 65°C 95% RH

### 3. Torus MMB.A.EXTMA.16-- Ø16mm

#### Olympian Series Application



### 3.1 Drawing MMB.A.EXTMA.16

### Main Base

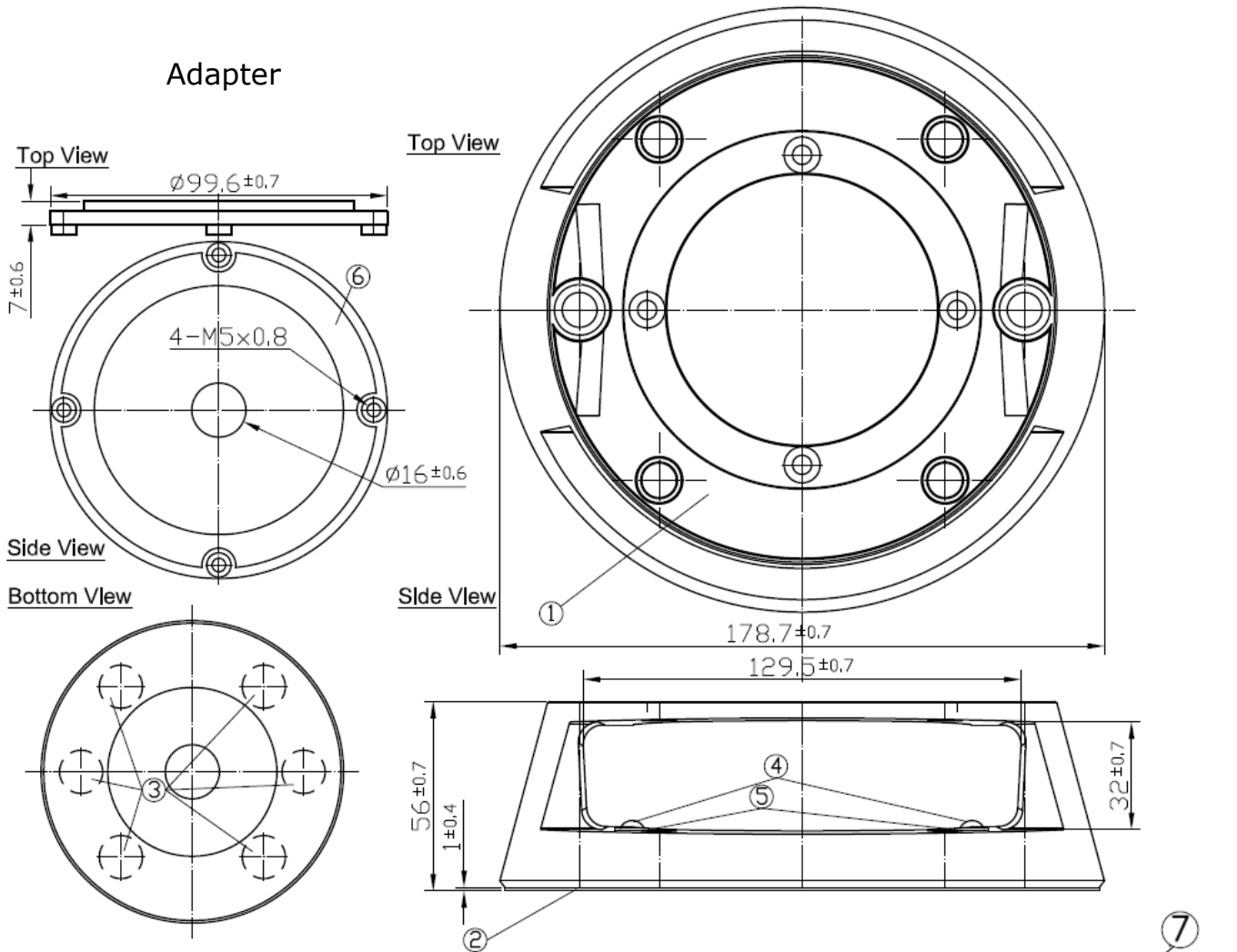

	Name	Material	Finish	QTY
1	MMB.A.EXTMA Base	ABS	Black	1
2	3M Adhesive With Foam	CR4305 1t+3M9448	Black	1
3	MMB.A.EXTMA_Magnet	Magnet	N/A	6
4	Round_head_5x10_Screw	SUS 302	N/A	6
5	3/16 Washer	SUS 302	N/A	6
6	MMB.A.M16 Adapter	ABS	Black	1
7	Flat_head_5x10_Screw	SUS 302	N/A	4

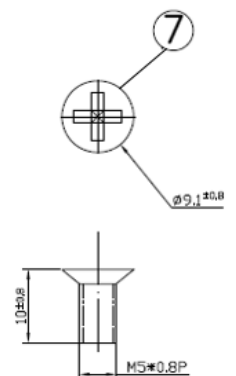



### 3.2 Installation MMB.A.EXTMA.16

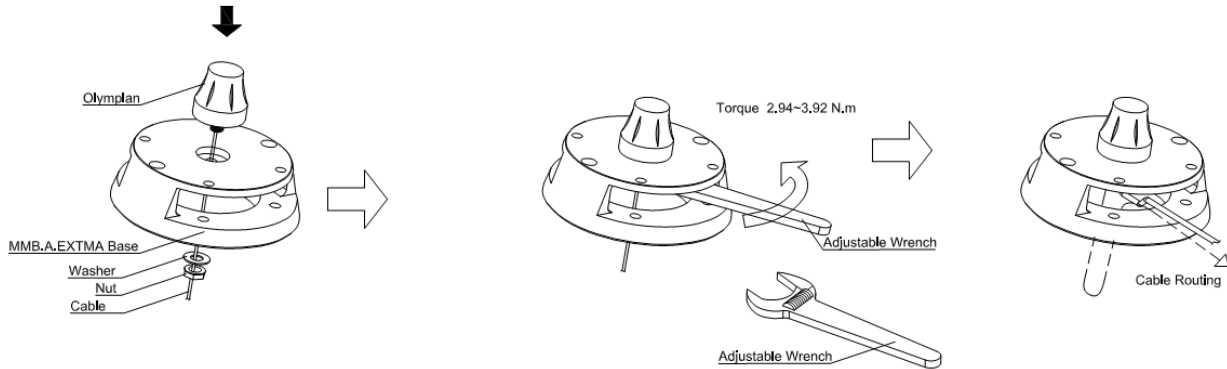

### 3.3 Installation Maximum Torque Recommendation

MMB.A.EXTMA.16 – For Olympian Series

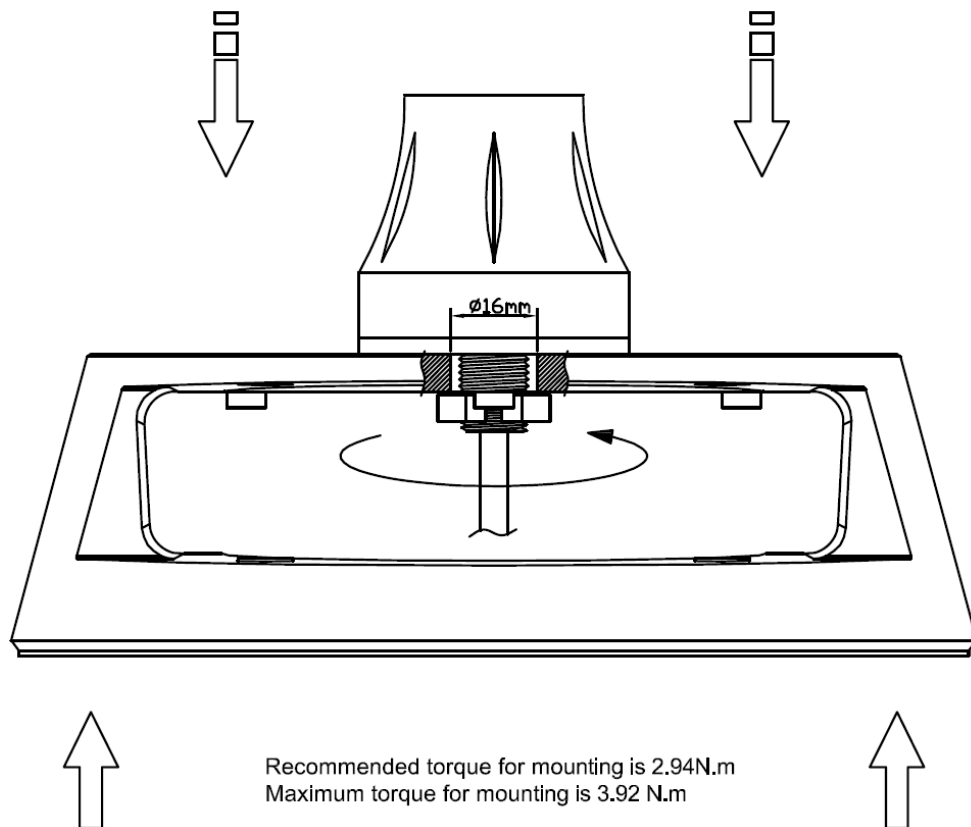

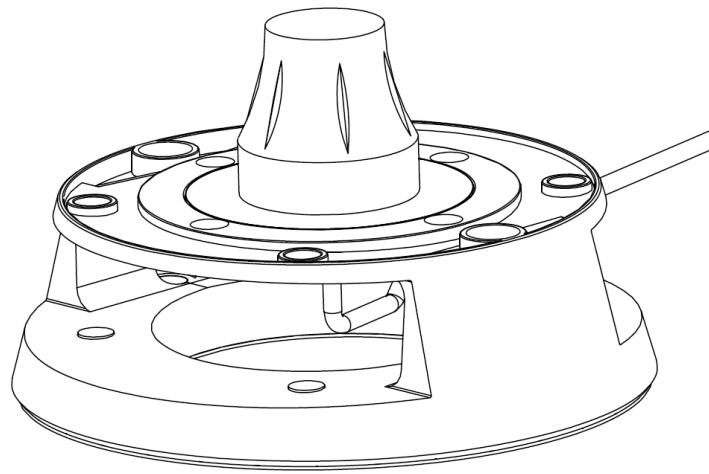

### 3.4 Packaging MMB.A.EXTMA.16

#### MMB.A.EXTMA.16

#### Packaging Specifications

1 MMB.A.EXTMA.16 per box  
 Tray Dimensions - 200\*185\*60mm  
 Weight - 580g

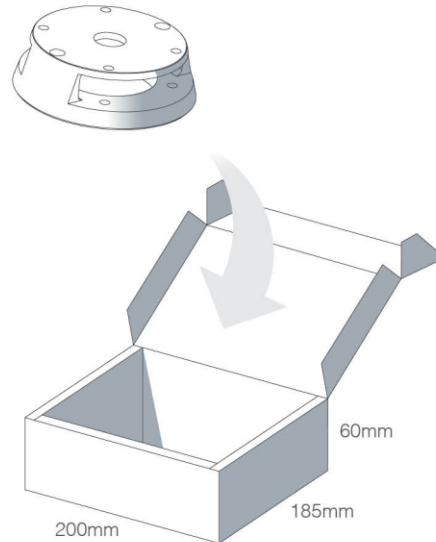

16 boxes per carton  
 Carton Dimensions - 430\*380\*290mm  
 Weight - 10.1Kg

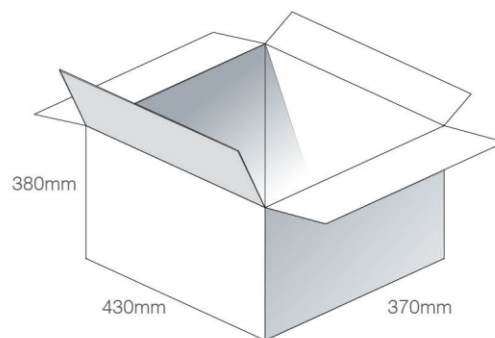

Pallet Dimensions 1100\*1100\*1310mm  
 8 Cartons per Pallet  
 2 Cartons per layer  
 4 Layers

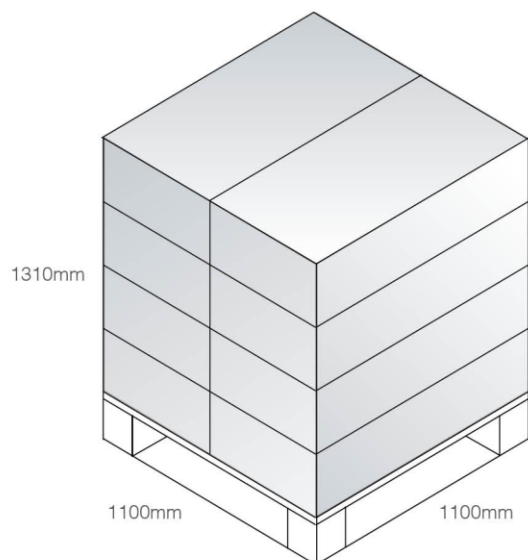

## 4. Torus MMB.A.EXTMA.19-- Ø19mm Hercules Series Application



### 4.1 Drawing MMB.A.EXTMA.19

#### Main Base

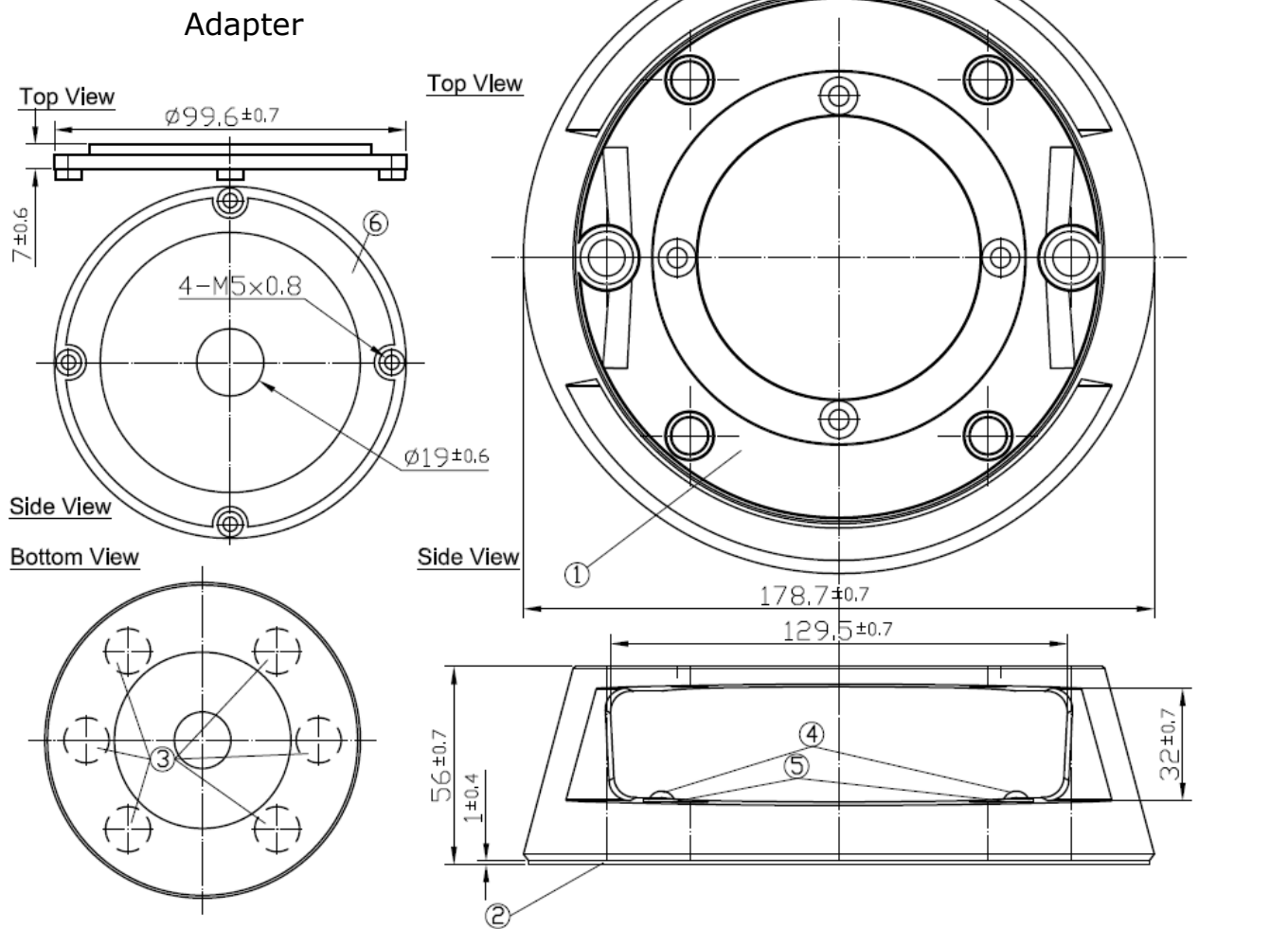

	Name	Material	Finish	QTY
1	MMB.A.EXTMA Base	ABS	Black	1
2	3M Adhesive With Foam	CR4305 1t+3M9448	Black	1
3	MMB.A.EXTMA_Magnet	Magnet	N/A	6
4	Round_head_5x10_Screw	SUS 302	N/A	6
5	3/16 Washer	SUS 302	N/A	6
6	MMB.A.M19 Adapter	ABS	Black	1
7	Flat_head_5x10_Screw	SUS 302	N/A	4

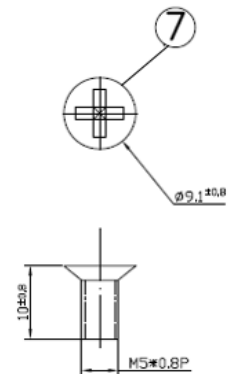

## 4.2 Installation MMB.A.EXTMA.19

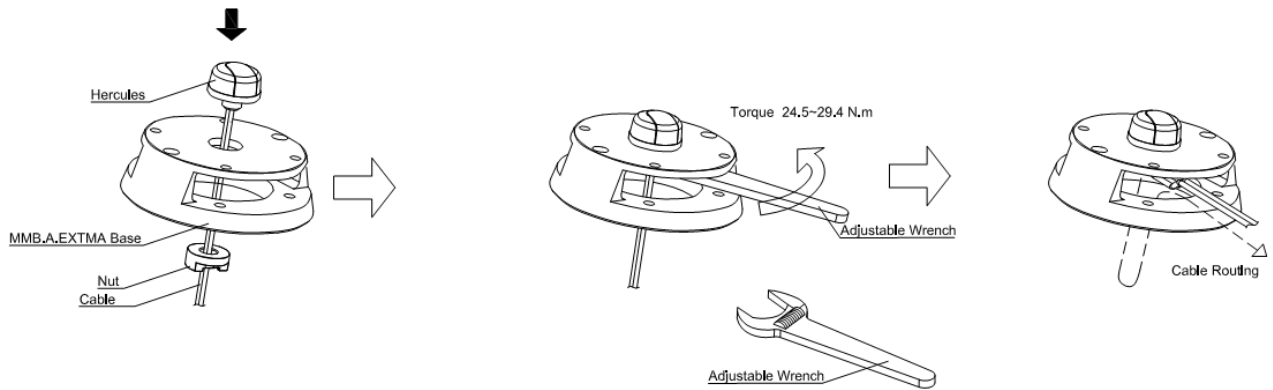

## 4.3 Installation Maximum Torque Recommendation

MMB.A.EXTMA.19 – For Hercules Series

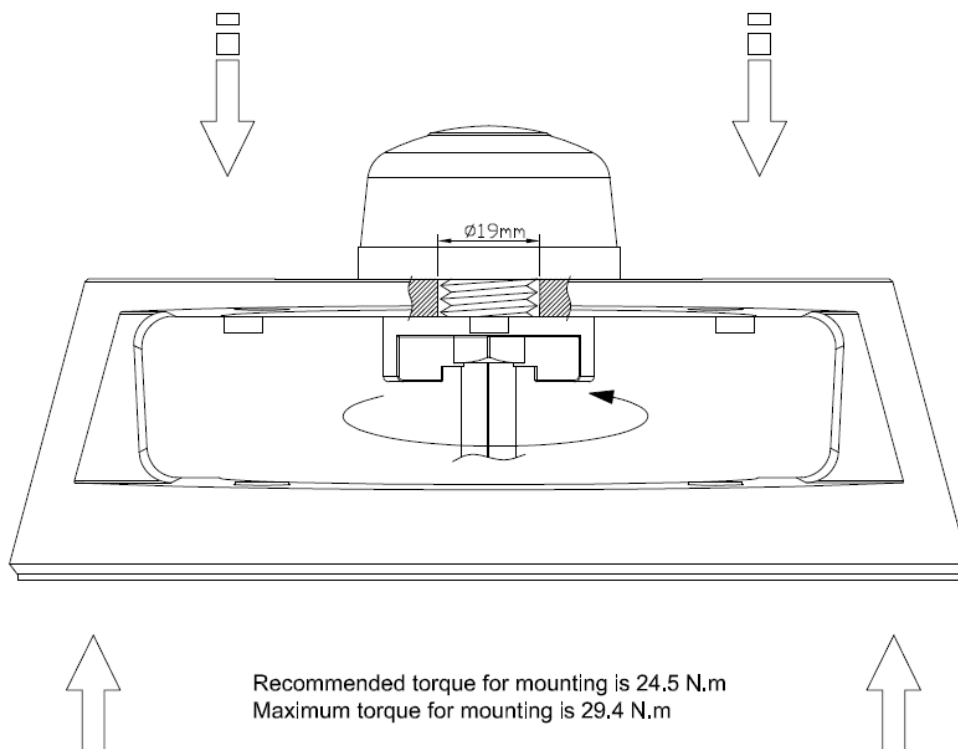

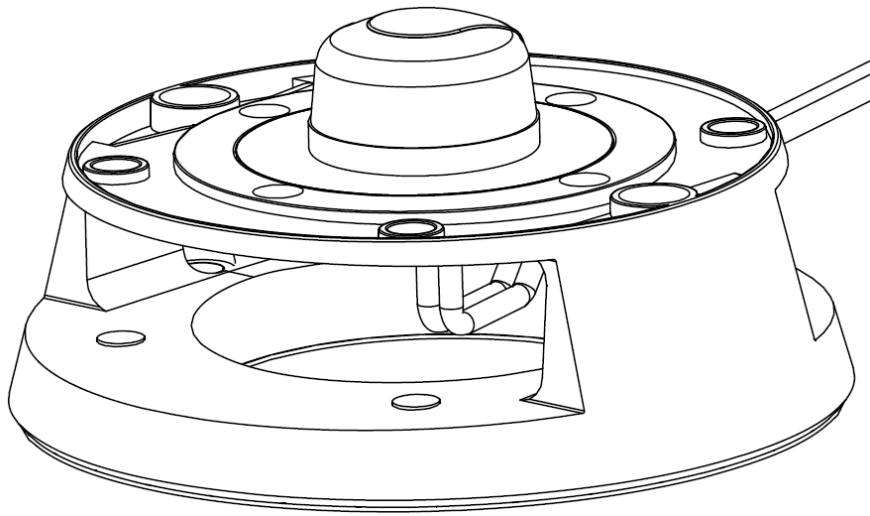

## 4.4 Packaging MMB.A.EXTMA.19

### MMB.A.EXTMA.19

#### Packaging Specifications

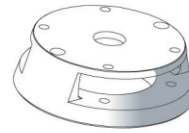

1 MMB.A.EXTMA.19 per box  
 Tray Dimensions - 200\*185\*60mm  
 Weight - 570g

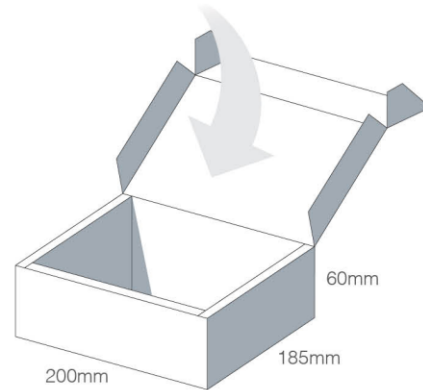

16 boxes per carton  
 Carton Dimensions - 430\*380\*290mm  
 Weight - 10Kg

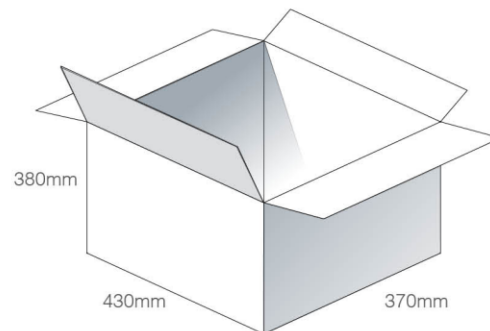

Pallet Dimensions 1100\*1100\*1310mm  
 8 Cartons per Pallet  
 2 Cartons per layer  
 4 Layers

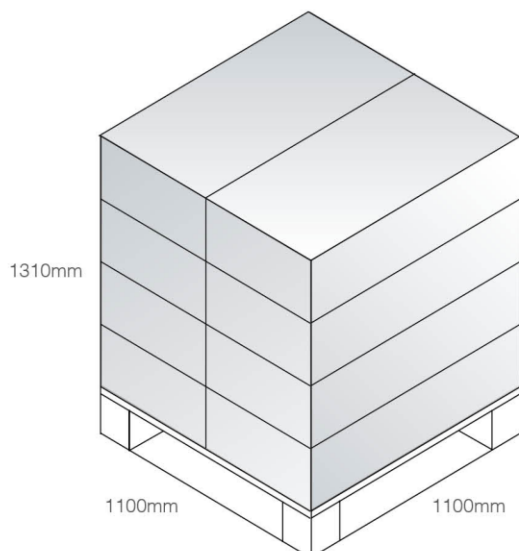



## 5. Torus MMB.A.EXTMA.21—Ø21mm

### 5.1 Spartan ST Series Application



### 5.2 Pantheon ST Series Application



### 5.3 Drawing MMB.A.EXTMA.21

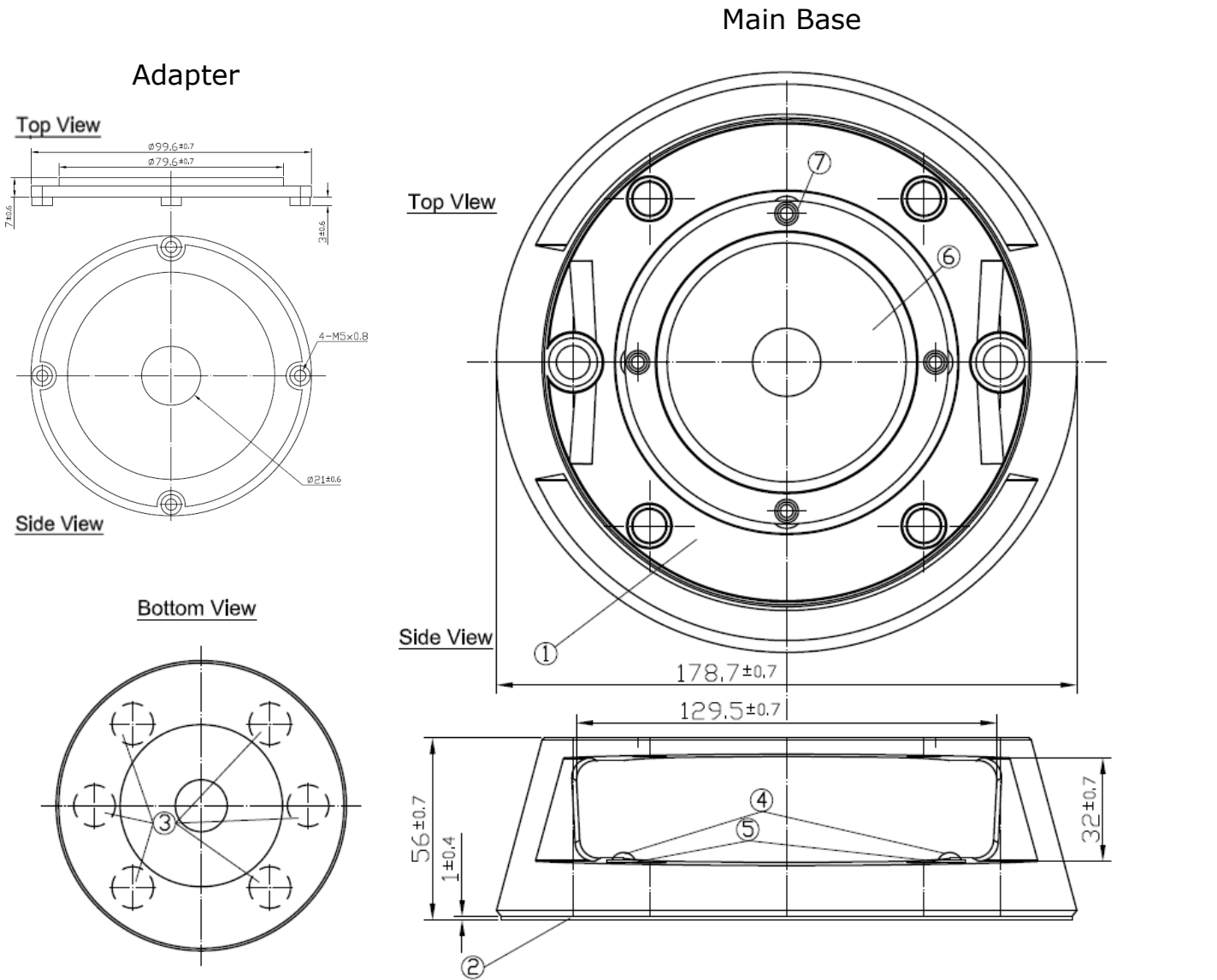

	Name	Material	Finish	QTY
1	MMB.A.EXTMA Base	ABS	Black	1
2	3M Adhesive With Foam	CR4305 1t+3M9448	Black	1
3	MMB.A.EXTMA_Magnet	Magnet	N/A	6
4	Round_head_5x10_Screw	SUS 302	N/A	6
5	3/16 Washer	SUS 302	N/A	6
6	MMB.A.M21 Adapter	ABS	Black	1
7	Flat_head_5x10_Screw	SUS 302	N/A	4

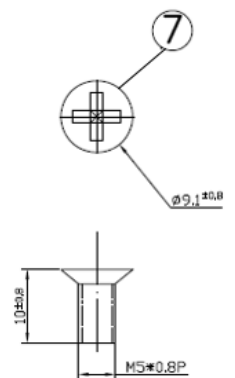

## 5.4 Installation Spartan ST series

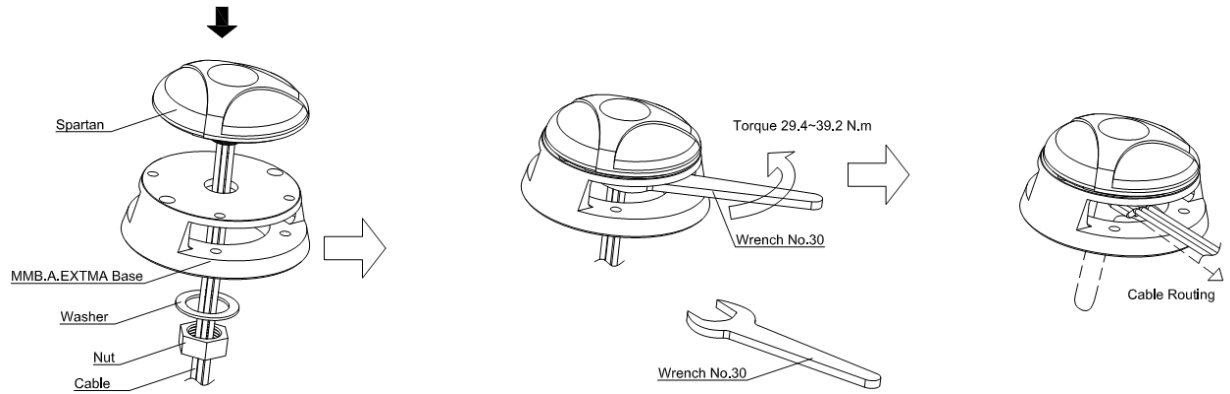

## 5.5 Installation Pantheon ST series

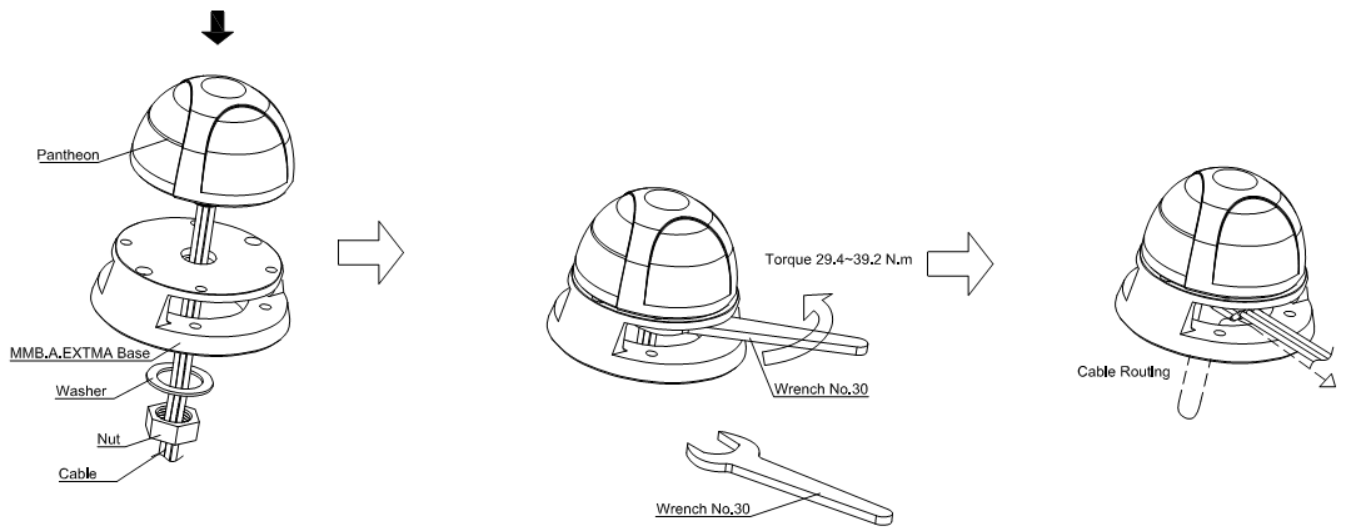

## 5.6 MMB.A.EXTMA.21 – For Spartan ST Version & Pantheon ST Version Series

### 5.6.1 Spartan ST

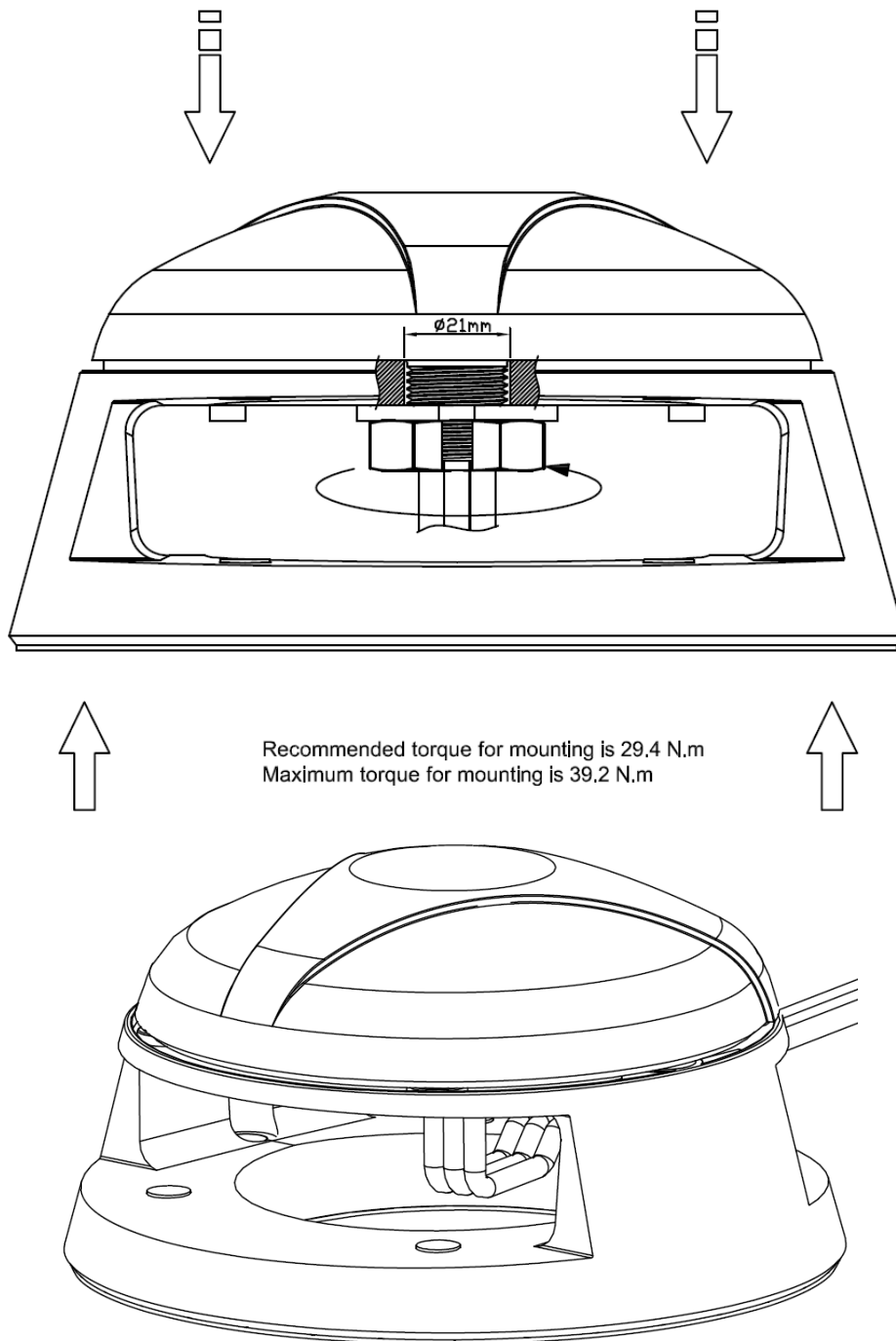

### 5.6.2 Pantheon ST

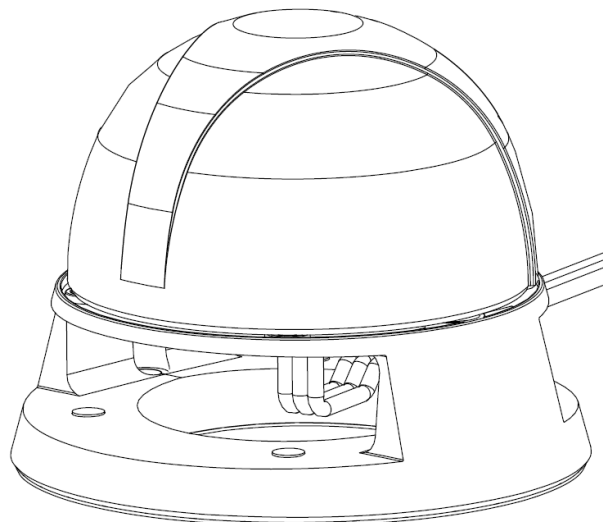
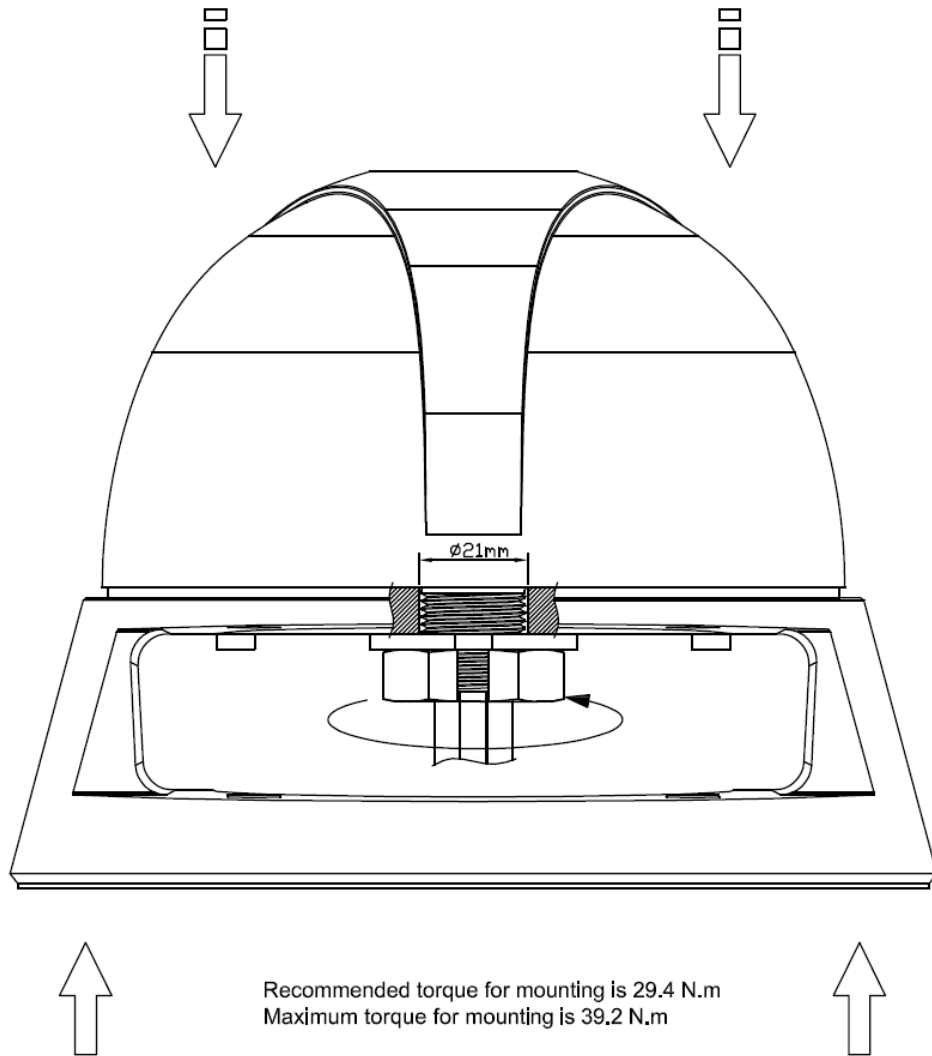

## 5.7 Packaging MMB.A.EXTMA.21

### MMB.A.EXTMA.21

#### Packaging Specifications

1 MMB.A.EXTMA.21 per box  
 Tray Dimensions - 200\*185\*60mm  
 Weight - 581g

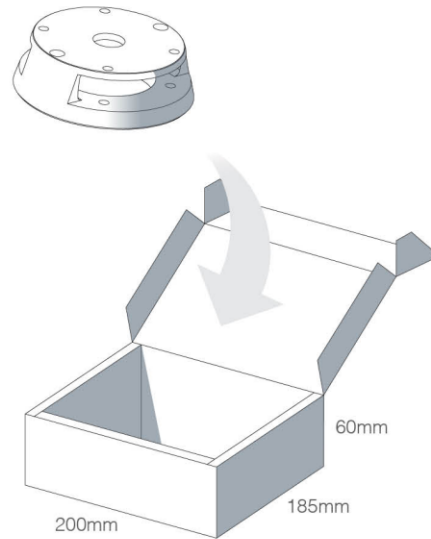

16 boxes per carton  
 Carton Dimensions - 430\*380\*290mm  
 Weight - 10.3Kg

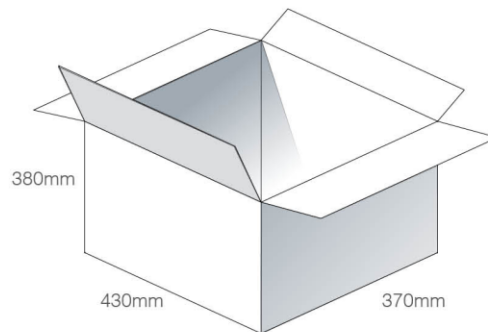

Pallet Dimensions 1100\*1100\*1310mm  
 8 Cartons per Pallet  
 2 Cartons per layer  
 4 Layers

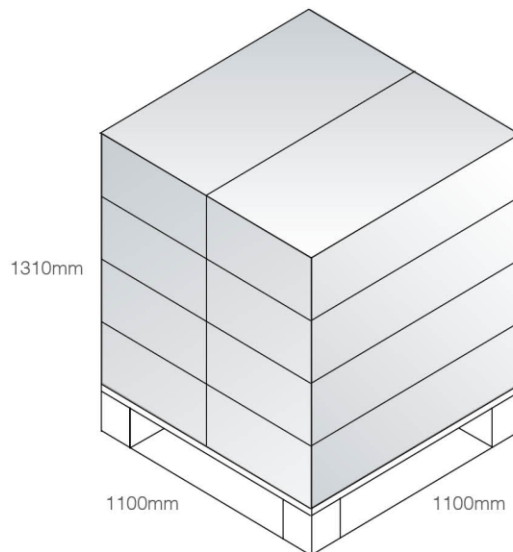

## 6. Torus MMB.A.EXTMA.31—Ø31mm

### 6.1 Ultima Series Application



### 6.2 Spartan Series Application



### 6.3 Pantheon Series Application





## 6.4 Drawing MMB.A.EXTMA.31

### Main Base

#### Adapter

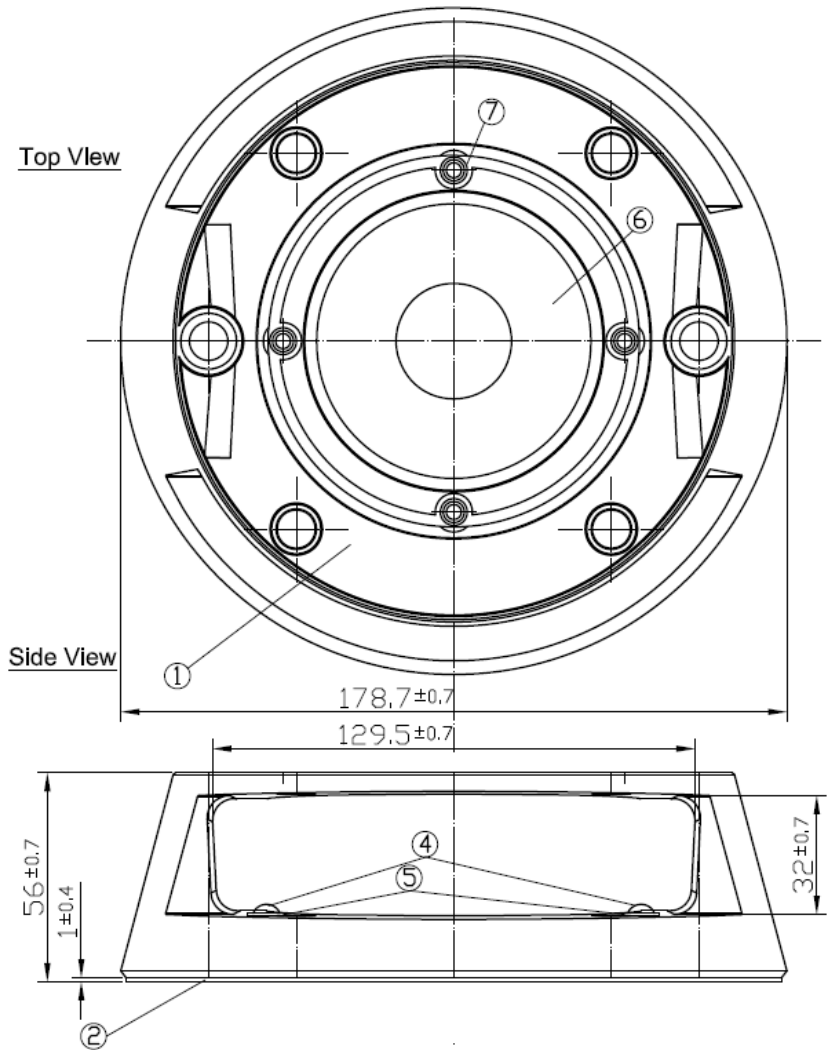
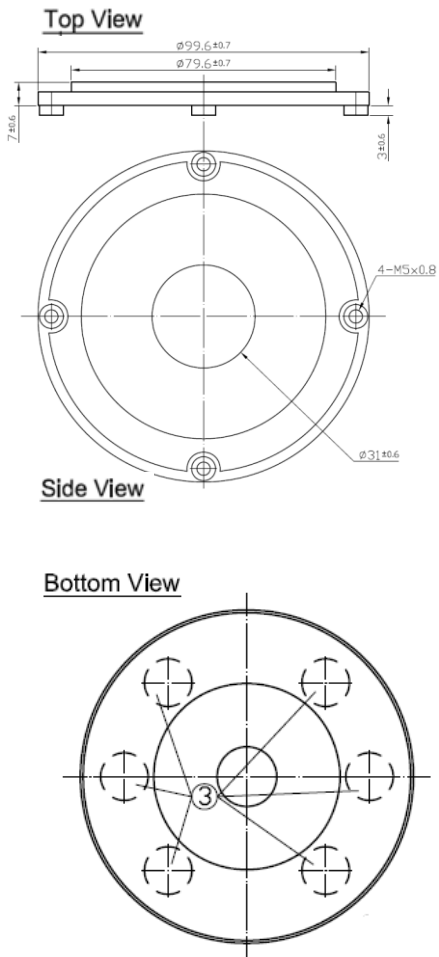

	Name	Material	Finish	QTY
1	MMB.A.EXTMA Base	ABS	Black	1
2	3M Adhesive With Foam	CR4305 1t+3M9448	Black	1
3	MMB.A.EXTMA_Magnet	Magnet	N/A	6
4	Round_head_5x10_Screw	SUS 302	N/A	6
5	3/16 Washer	SUS 302	N/A	6
6	MMB.A.M31 Adapter	ABS	Black	1
7	Flat_head_5x10_Screw	SUS 302	N/A	4

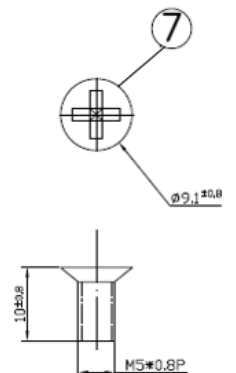

## 6.5 Installation Ultima Series

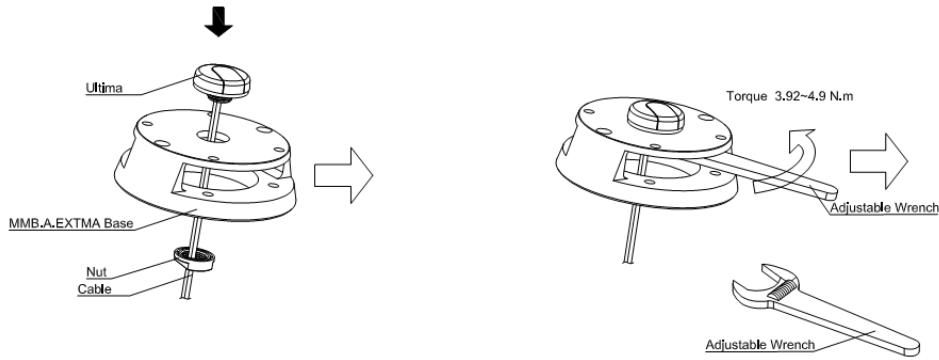

## 6.6 Spartan Series

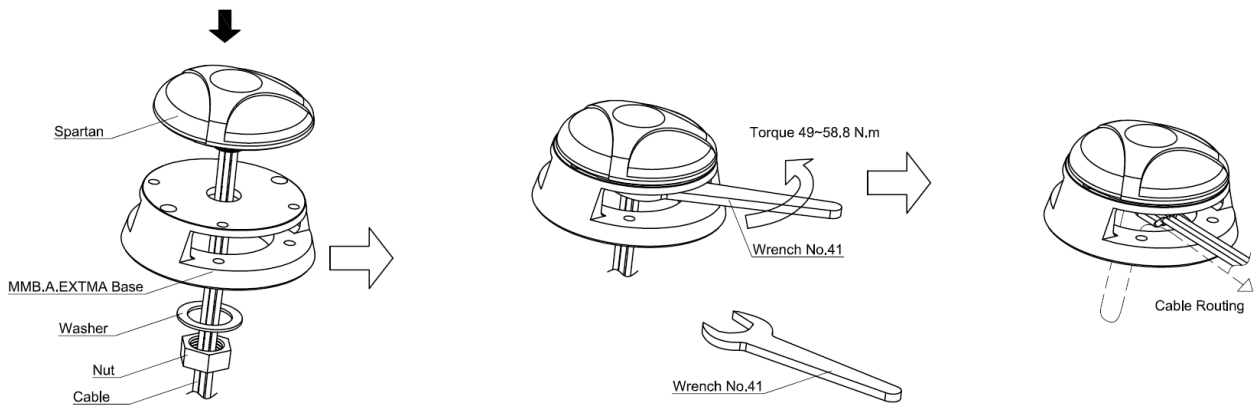

## 6.7 Pantheon Series

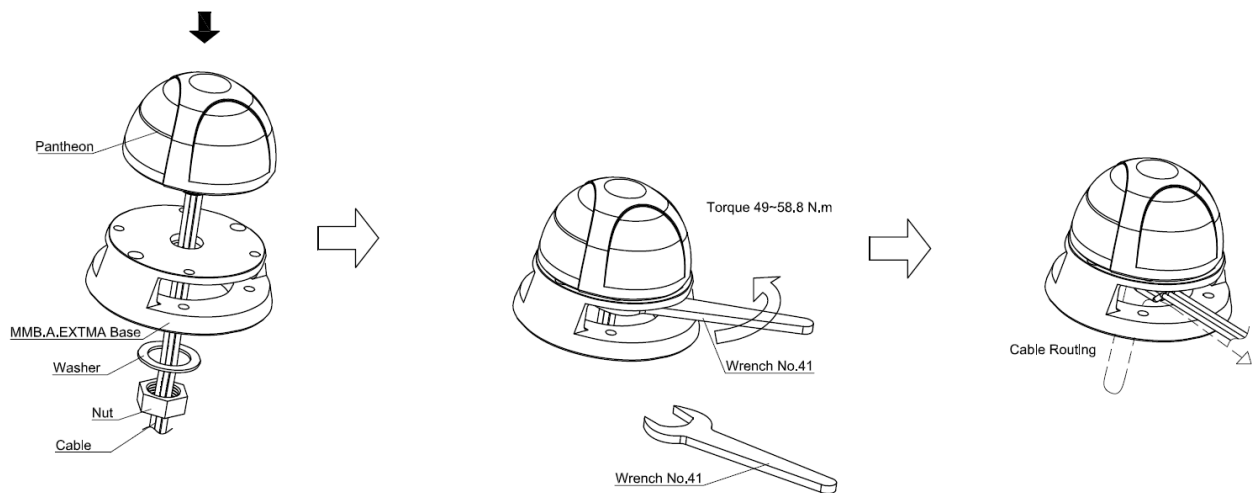

## 6.8 MMB.A.EXTMA.31 – For Ultima, Spartan, & Pantheon Series

### 6.8.1 Ultima

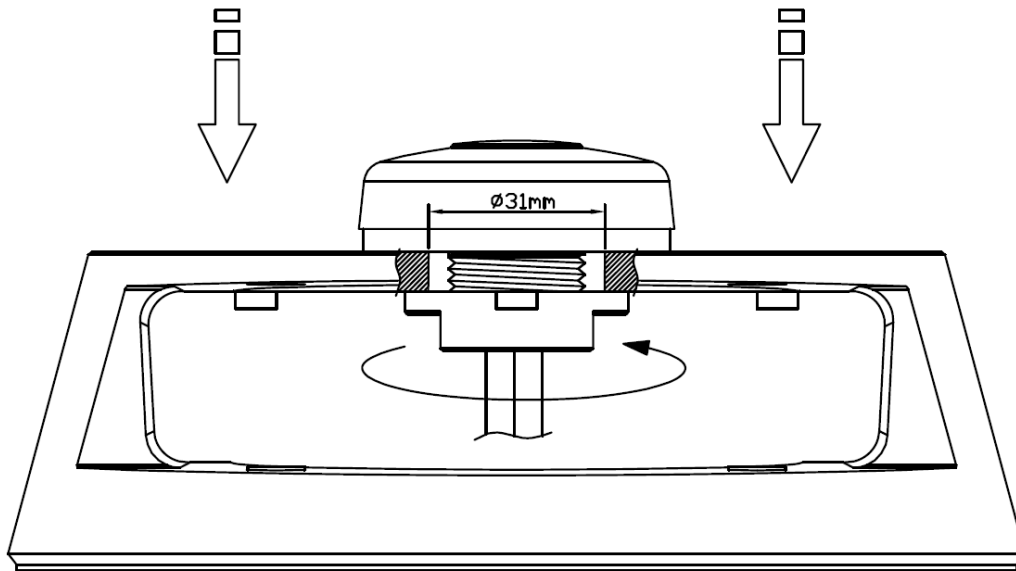

Recommended torque for mounting is 3.92 N.m  
Maximum torque for mounting is 4.9 N.m

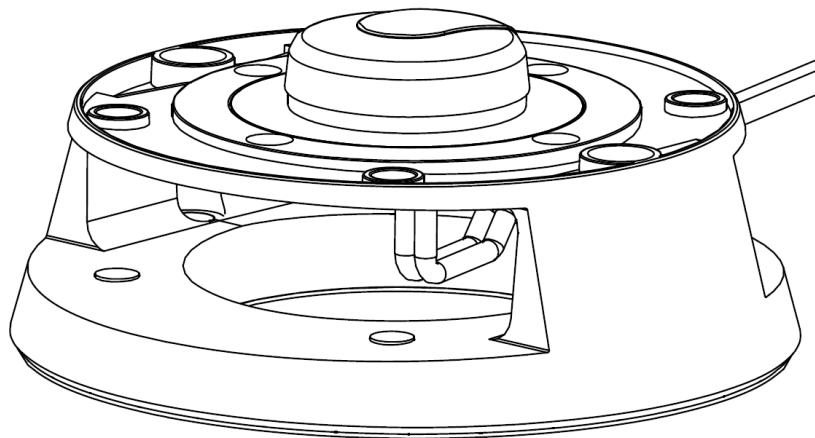

### 6.8.2 Spartan

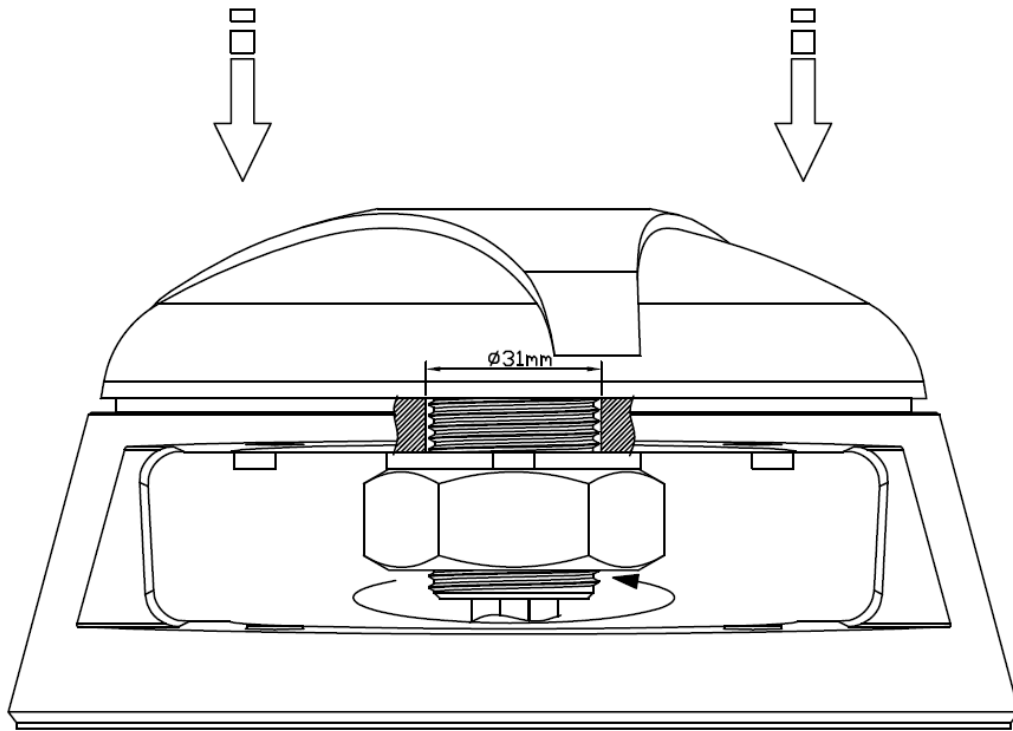

Recommended torque for mounting is 49 N.m  
Maximum torque for mounting is 58.8 N.m

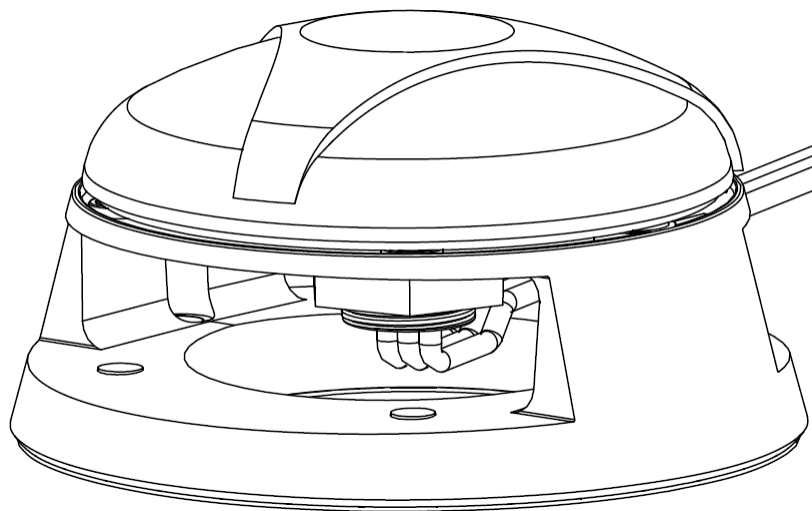

### 6.8.3 Pantheon

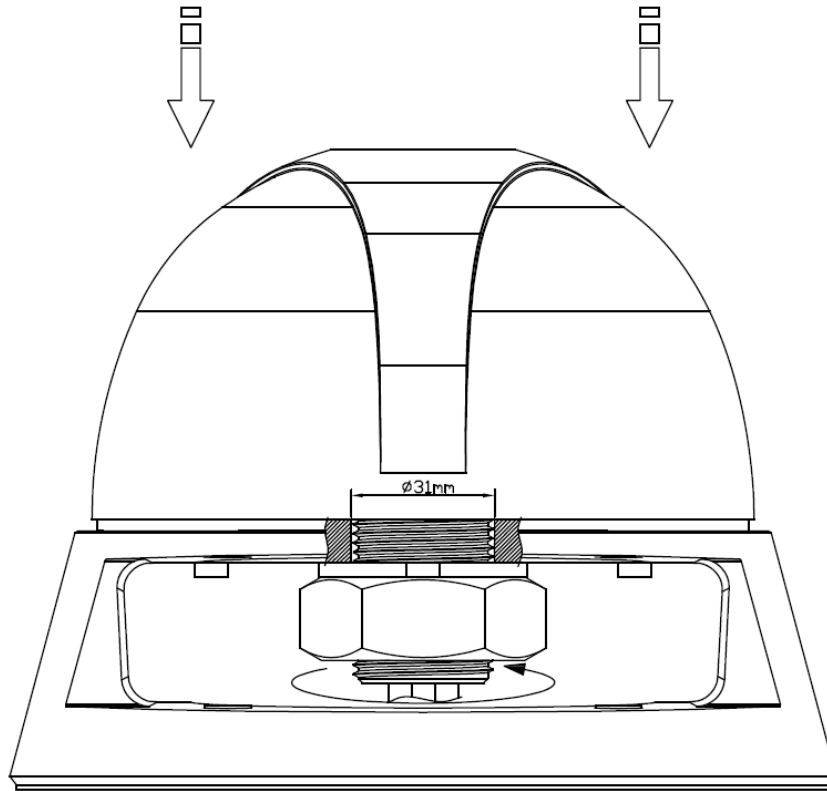

Recommended torque for mounting is 49 N.m  
Maximum torque for mounting is 58,8 N.m

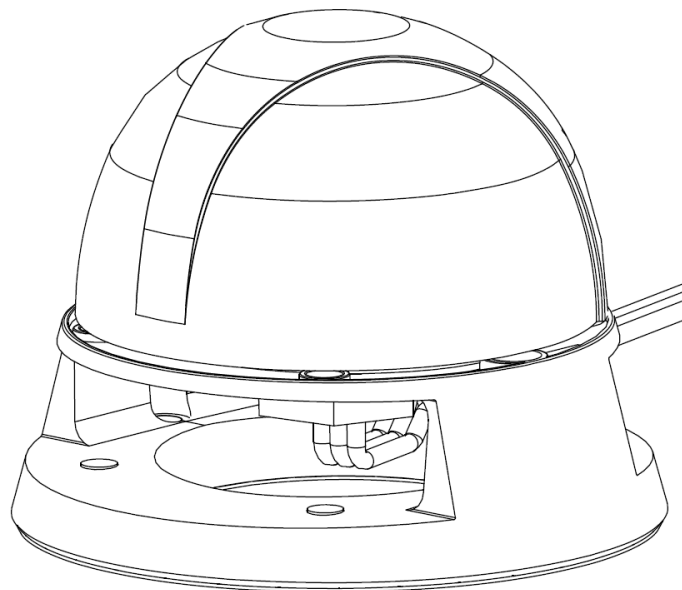

## 6.9 Packaging MMB.A.EXTMA.31

### MMB.A.EXTMA.31

#### Packaging Specifications

1 MMB.A.EXTMA.31 per box  
 Tray Dimensions - 200\*185\*60mm  
 Weight - 572g

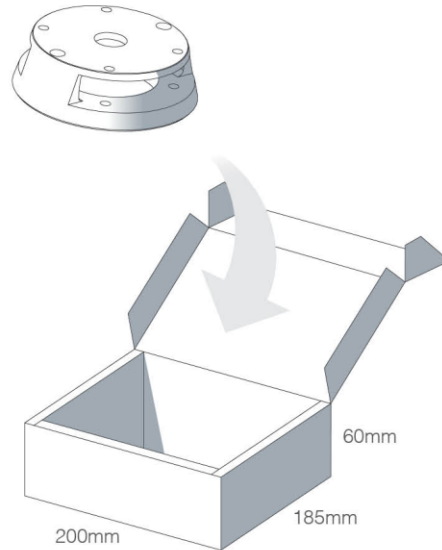

16 boxes per carton  
 Carton Dimensions - 430\*380\*290mm  
 Weight - 10.1Kg

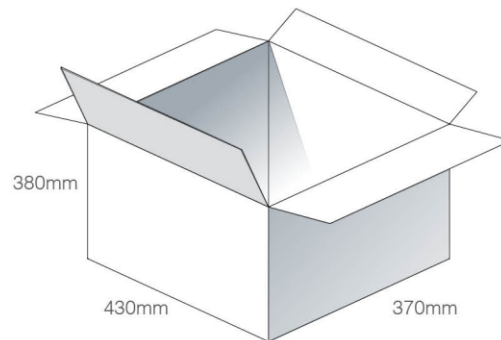

Pallet Dimensions 1100\*1100\*1310mm  
 8 Cartons per Pallet  
 2 Cartons per layer  
 4 Layers

