

TS809/810/809R/810R Series

Microprocessor Reset Circuit

SOT-23



Pin Definition:

TS809/TS810

1. Ground
2. RESET(RESET)
3. Vcc

TS809R/TS810R

1. RESET(RESET)
2. Ground
3. Vcc

General Description

The TS809/810 series are microprocessor (μ P) supervisory circuit used to monitor the power supplies in μ P and digital systems. They provide excellent circuit reliability and low cost by eliminating external components and adjustments when used with +5V, +3.3V, +3.0V powered circuits. These circuits perform a single function: they assert a reset signal whenever the VCC supply voltage declines below a preset threshold, keeping it asserted for at least 140ms after VCC has risen above the reset threshold. Reset thresholds suitable for operation with a variety of supply voltages are available. The TS809/810 series have push pull outputs. The TS809/809R have an active low RESET output, while the TS810/810R has an active high (RESET) output. The reset comparator is designed to ignore fast transients on VCC, and the output guaranteed to be in the correct logic state for VCC down to 1V. Low supply correct makes the TS809/810 series ideal for use in portable equipment.

Features

- Highly Accurate: $\pm 2\%$
- Precision monitoring of +3V, +3.3V and +5V power supply voltage
- Fully specified over temperature
- Available in three output configurations
- Push-Pull RESET low output (TS809/TS809R)
- Push-Pull (RESET) high output (TS810/TS810R)
- 140mS min. power-on reset pulse width
- 12uA supply current
- Guaranteed reset valid to Vcc = +1V
- Power supply transient immunity
- No external components

Applications

- Battery-operated systems
- Controllers
- Intelligent instruments
- Critical uP and uC power monitoring
- Portable / Battery powered equipment
- Automotive

Pin Descriptions

Name	Description
Gnd	Ground
RESET (RESET)	RESET – TS809 / TS809R (Active Low) (RESET) – TS810 / TS810R (Active High)
Vcc	Operating voltage input

Ordering Information

Part No.	Package	Packing
TS809CX _x RF	SOT-23	3Kpcs / 7" Reel
TS810CX _x RF	SOT-23	3Kpcs / 7" Reel
TS809RCX _x RF	SOT-23	3Kpcs / 7" Reel
TS810RCX _x RF	SOT-23	3Kpcs / 7" Reel

Note: _x is the threshold voltage type, option as

A : 4.63V B : 4.38V C : 4.00V D : 3.08V
 E : 2.93V F : 2.63V G : 2.32V H : 2.1V
 I : 2.0V

Application Circuit

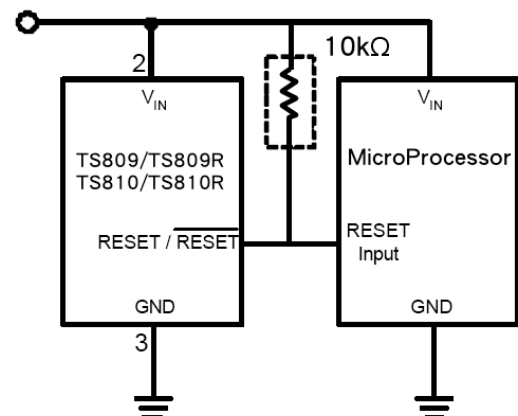

Absolute Maximum Rating

Parameter	Symbol	Maximum	Unit
Terminal Voltage (with respect to Gnd)	V_{CC}	7	V
<u>RESET</u> & (RESET) push-pull	V_{RESET}	- 0.3 ~ ($V_{CC} + 0.3$)	V
Input Current, V_{CC}	I_{CC}	20	mA
Output Current, <u>RESET</u> , (RESET)	I_O	20	mA
Rate of Rise, V_{CC}	V_R	100	V/ μ S
Continuous Power Dissipation	P_D	320	mW
Operating Junction Temperature Range	T_{OPR}	-40 ~ +125	$^{\circ}$ C
Storage Temperature Range	T_{STG}	-65 ~ +150	$^{\circ}$ C
Lead Soldering Temperature (260 $^{\circ}$ C)	T_{LEAD}	10	S

Electrical Specifications (Ta = 25 $^{\circ}$ C, unless otherwise noted)

Parameter	Conditions	Symbol	Min	Typ	Max	Unit
Input Supply Voltage	Ta=-40 $^{\circ}$ C~+85 $^{\circ}$ C	V_{CC}	1.0	--	5.5	V
Supply Current	$V_{IN}=V_{IN} * 1.10$	I_{CC}	--	--	3.0	μ A
	$V_{IN}=V_{IN} * 1.10, T_a=-40^{\circ}\text{C}\sim+85^{\circ}\text{C}$		-	--	5.0	
Reset Threshold	TS809/809R/810/810RCXA	V_{TH}	4.56	4.63	4.7	V
	TS809/809R/810/810RCXB		4.31	4.38	4.45	
	TS809/809R/810/810RCXC		3.94	4.00	4.06	
	TS809/809R/810/810RCXD		3.03	3.08	3.13	
	TS809/809R/810/810RCXE		2.89	2.93	2.97	
	TS809/809R/810/810RCXF		2.59	2.63	2.67	
	TS809/809R/810/810RCXG		2.28	2.32	2.35	
	TS809CXH		2.07	2.1	2.13	
	TS809CXI		1.97	2.0	2.03	
Reset Threshold Temperature Coefficient			30	50	160	ppm/ $^{\circ}$ C
VCC to Reset Delay	$V_{CC} = V_{TH} - 100\text{mV}$	T_{DELAY}	--	40	--	μ S
Reset Active Timeout Period	Ta=-40 $^{\circ}$ C~+85 $^{\circ}$ C		140	210	500	mS
RESET Output (TS809/R) Voltage Low	$V_{CC} < V_{TH(MAX)}, I_{SINK} = 1.2\text{mA}$	V_{OL}	--	--	0.2	V
RESET Output (TS809/R) Voltage High	$V_{CC} > V_{TH(MAX)}, I_{SOURCE} = 0.5\text{mA}, V_{CC} > 1.8\text{V}$	V_{OH}	0.8	--	--	V
	$V_{CC} > V_{TH(MAX)}, I_{SOURCE} = 0.15\text{mA}, 1.8\text{V} \geq V_{CC} > 1.0\text{V}$		VCC	--	--	
(RESET) Output (TS810/R) Voltage Low	$V_{CC} > V_{TH(MAX)}, I_{SINK} = 1.2\text{mA}$	V_{OL}	--	--	0.2	V
(RESET) Output (TS810/R) Voltage High	$V_{CC} < V_{TH(MAX)}, I_{SOURCE} = 0.5\text{mA}, V_{CC} > 1.8\text{V}$	V_{OH}	0.8	--	--	V
	$V_{CC} > V_{TH(MAX)}, I_{SOURCE} = 0.15\text{mA}, 1.8\text{V} \geq V_{CC} > 1.0\text{V}$		VCC	--	--	

Application Note

Function Description

A microprocessor's (μP 's) reset input starts the μP in a known state. The TS809/810/809R/810R assert reset to prevent code-execution errors during power-up, power-down, or brownout conditions. They assert a reset signal whenever the V_{CC} supply voltage declines below a preset threshold, keeping it asserted for at least 140ms after V_{CC} has risen above the reset threshold. The TS809/810/809R/810R have a push-pull output stage.

Applications Information

Negative-Going V_{CC} transients in addition to issuing a reset to the μP during power-up, power-down, and brownout conditions, the TS809/810 are relatively immune to short-duration negative-going V_{CC} transients (glitches).

The TS809/810/809R/810R do not generate a reset pulse. The graph was generated using a negative going pulse applied to V_{CC} , starting 0.5V above the actual reset threshold and ending below it by the magnitude indicated (reset comparator overdrive). The graph indicates the maximum pulse width a negative going V_{CC} transient can have without causing a reset pulse. As the magnitude of the transient increases (goes farther below the reset threshold), the maximum allowable pulse width decreases. Typically, a V_{CC} transient that goes 100mV below the reset threshold and lasts 20 μS or less will not cause a reset pulse. A 0.1 μF bypass capacitor mounted as close as possible to the V_{CC} pin provides additional transient immunity.

Ensuring a Valid Reset Output Down to $V_{CC}=0$

When V_{CC} falls below 1V, the TS809/810/809R/810R reset output no longer sinks current - it becomes an open circuit. Therefore, high impedance CMOS logic input connected to reset can drift to undetermined voltages.

This presents no problem in most applications since most μP and other circuitry is inoperative with V_{CC} below 1V. However, in applications where reset must be valid down to 0V, adding a pull down resistor to reset causes and stray leakage currents to flow to ground, holding reset low (Figure 2.) R_1 's value is not critical; 100K is large enough not to load reset and small enough to pull RESET to ground. For the TS809/810/809R/810R if reset is required to remain valid for $V_{CC} < 1V$.

Benefits of Highly Accurate Reset Threshold

Most μP supervisor ICs have reset threshold voltages between 5% and 10% below the value of nominal supply voltages. This ensures a reset will not occur within 5% of the nominal supply, but will occur when the supply is 10% below nominal. When using ICs rated at only the nominal supply $\pm 5\%$, this leaves a zone of uncertainty where the supply is between 5% and 10% low, and where the reset may or may not be asserted

Timing Diagram

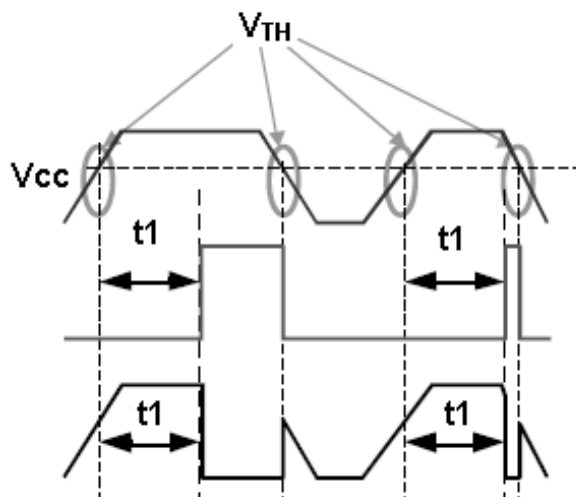

Electrical Characteristics Curve

Figure 1. Reset Time vs. Temperature

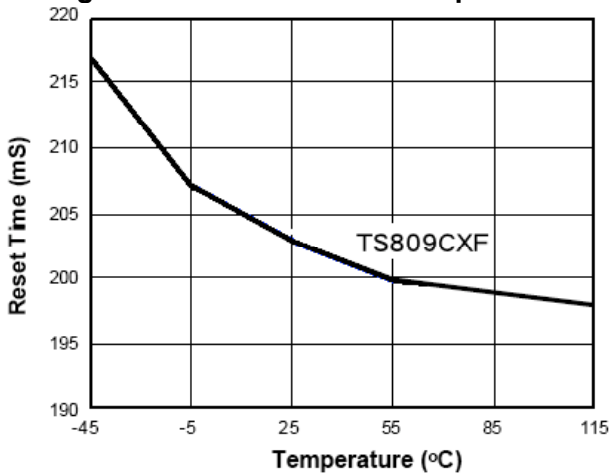

Figure 2. Threshold vs. Temperature

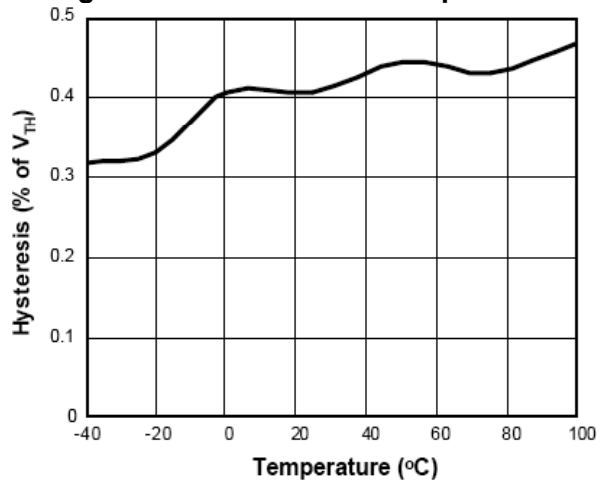

Figure 3. I_{IN} vs. Temperature

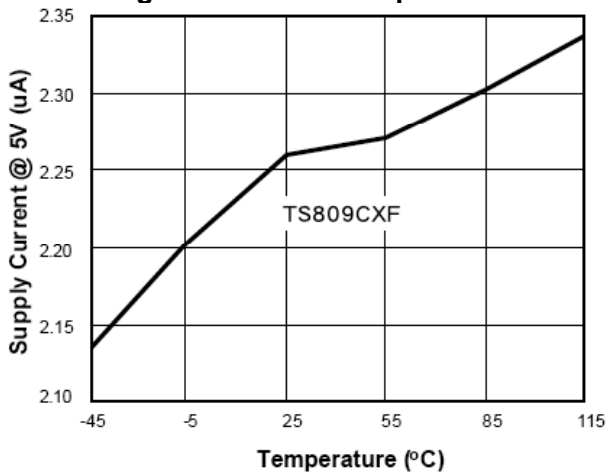

Figure 4. Reset Time vs. Temperature

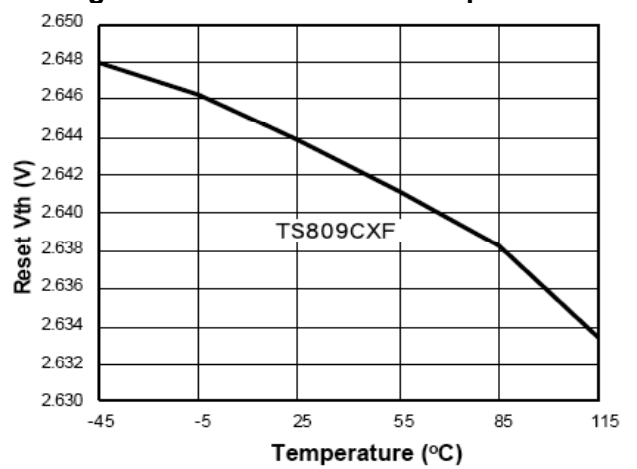

Figure 5. I_{IN} vs. V_{IN}

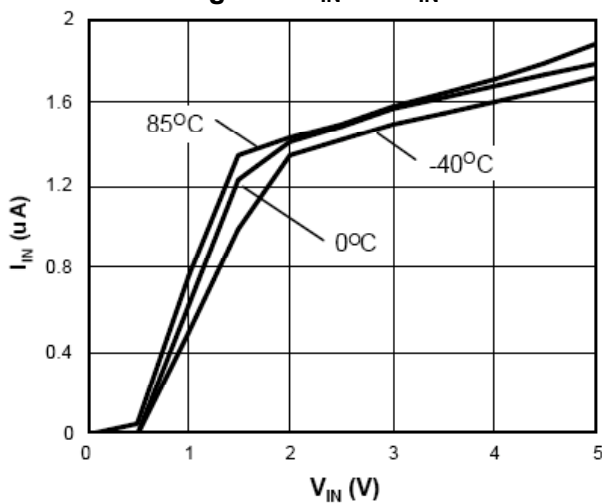
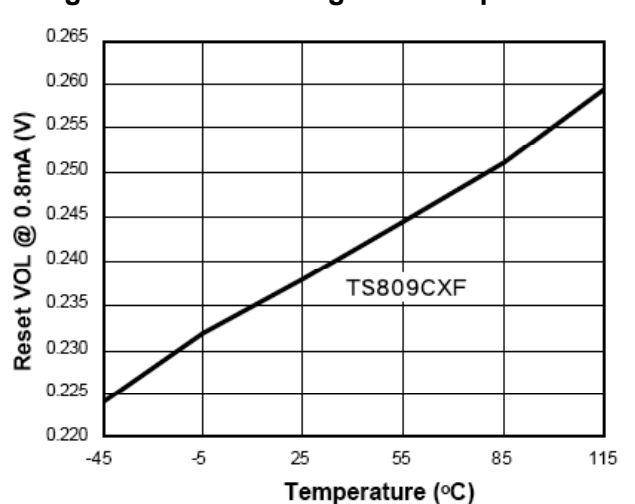

Figure 6. Reset Voltage vs. Temperature



TS809/810/809R/810R Series

Microprocessor Reset Circuit

Function Block

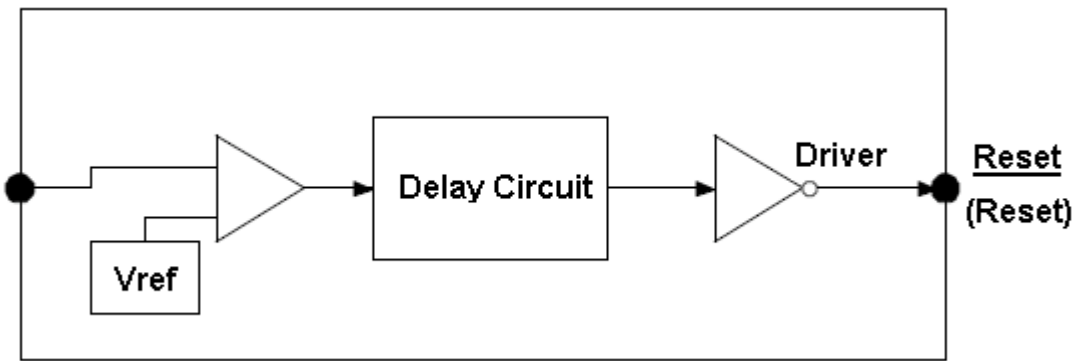

Marking Information

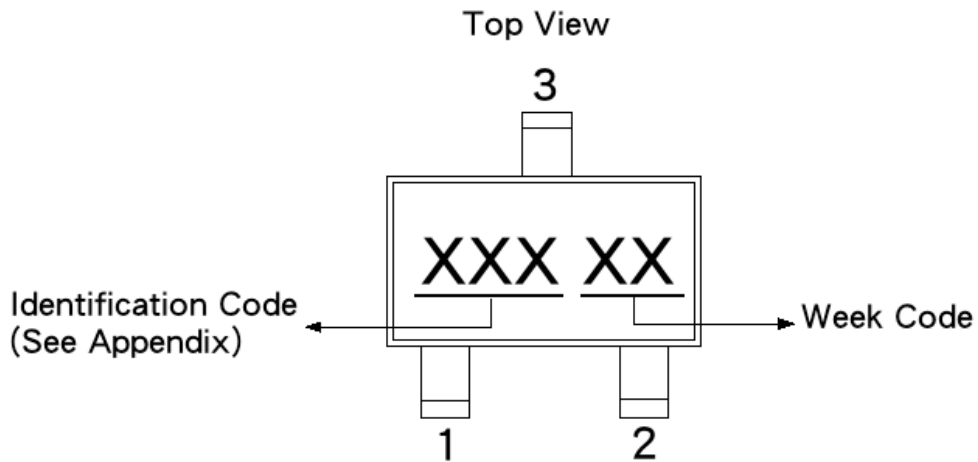

Part No.	Identification Code	Part No.	Identification Code	Part No.	Identification Code	Part No.	Identification Code
TS809CXA	ARK	TS810CXA	ARJ	TS809RCXA	ABA	TS810RCXA	ACA
TS809CXB	ARN	TS810CXB	ALS	TS809RCXB	ABB	TS810RCXB	ACB
TS809CXC	ASB	TS810CXC	AAC	TS809RCXC	ATQ	TS810RCXC	ACC
TS809CXD	ASA	TS810CXD	ASU	TS809RCXD	ATO	TS810RCXD	ACD
TS809CXE	AMO	TS810CXE	ALV	TS809RCXE	AUV	TS810RCXE	ACE
TS809CXF	AMP	TS810CXF	AZM	TS809RCXF	ABF	TS810RCXF	ACF
TS809CXG	ATT	TS810CXG	AAG	TS809RCXG	ABG	TS810RCXG	ACG
TS809CXH	ASK	--	--	--	--	--	--
TS809CXI	BDT	--	--	--	--	--	--

SOT-23 Mechanical Drawing

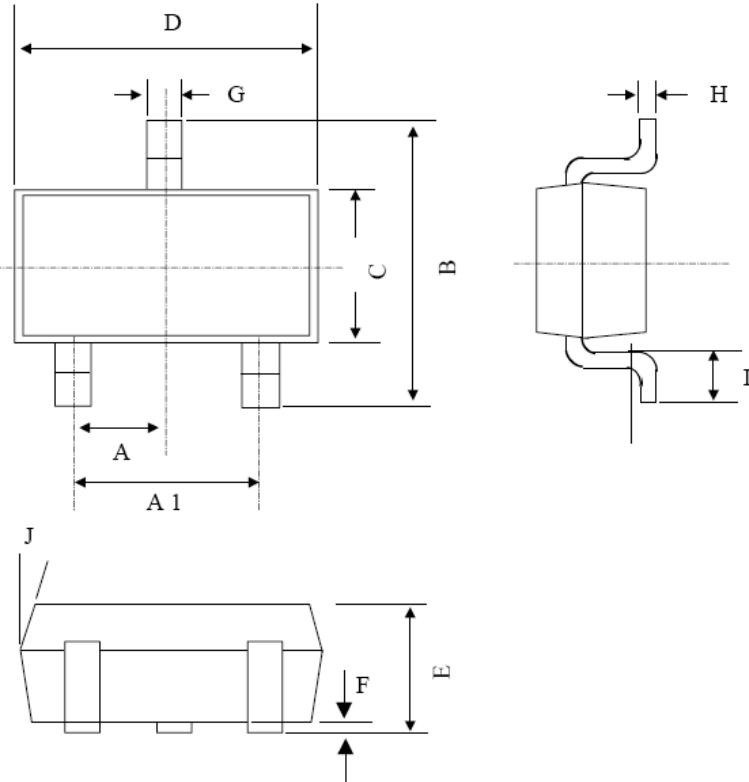

DIM	SOT-23 DIMENSION			
	MILLIMETERS		INCHES	
	MIN	MAX	MIN	MAX.
A	0.95 BSC		0.037 BSC	
A1	1.9 BSC		0.074 BSC	
B	2.40	3.00	0.094	0.118
C	1.40	1.80	0.055	0.070
D	2.70	3.10	0.106	0.122
E	1.00	1.40	0.039	0.055
F	0.00	0.15	0.000	0.059
G	0.35	0.50	0.014	0.020
H	0.09	0.25	0.003	0.009
I	0.35 BSC		0.0138 BSC	
J	5°	10°	5°	10°



TS809/810/809R/810R Series

Microprocessor Reset Circuit

Notice

Specifications of the products displayed herein are subject to change without notice. TSC or anyone on its behalf, assumes no responsibility or liability for any errors or inaccuracies.

Information contained herein is intended to provide a product description only. No license, express or implied, to any intellectual property rights is granted by this document. Except as provided in TSC's terms and conditions of sale for such products, TSC assumes no liability whatsoever, and disclaims any express or implied warranty, relating to sale and/or use of TSC products including liability or warranties relating to fitness for a particular purpose, merchantability, or infringement of any patent, copyright, or other intellectual property right.

The products shown herein are not designed for use in medical, life-saving, or life-sustaining applications. Customers using or selling these products for use in such applications do so at their own risk and agree to fully indemnify TSC for any damages resulting from such improper use or sale.