

## SGX-4NH3 Datasheet

### Industrial Ammonia Sensor

Application : Portable Gas Detectors

#### PERFORMANCE

Range .....	0 – 100 ppm
Typical Baseline Range (pure air) .....	<±1 ppm equivalent
Output Signal .....	100 ± 30nA/ppm
Linearity .....	Linear
Response Time, t90 .....	<40 s
Maximum Overload .....	200 ppm
Long-term Output Drift .....	<2% per month
Recommended Load Resistor .....	10 ohms
Repeatability .....	±10%
Bias voltage .....	0V (no bias)
Warranty .....	12 Months
Resolution.....	1 ppm

#### OPERATING CONDITIONS

Temperature Range .....	-40°C to +50°C
Operating Humidity .....	15% to 90% RH
Pressure Range .....	800 to 1200 mbar
Operating Circuit .....	see Electrochemical Toxic Sensor Application Note
Recommended Storage Temperature ....	0°C to 20°C
Expected Operating Life.....	> 24 Months in Air

#### INTRINSIC SAFETY DATA

Maximum at 2000 ppm .....	0.3 mA
Maximum o/c Voltage .....	1.3 V
Maximum s/c Current .....	<1.0 A

#### CROSS-SENSITIVITY DATA

Gas	CONC.	SGX-4NH3
Hydrogen Sulphide	25 ppm	30 ppm
Sulphur Dioxide	20 ppm	-6 ppm
Hydrogen	100 ppm	0 ppm
Nitric Oxide	50 ppm	0 ppm
Carbon Monoxide	500 ppm	0 ppm
Nitrogen Dioxide	5 ppm	-7.5 ppm
Ethanol	100 ppm	0 ppm
Carbon Dioxide	5000ppm	0 ppm

*Note: This table is for reference only and are typical values. Cross Sensitivities may not be linear and should not be scaled. Calibration should be carried out with the actual gas at a known concentration.*

This device is designed to be RoHS compliant.

#### PRODUCT DIMENSIONS

All dimensions in mm  
All tolerances ±0.15 mm

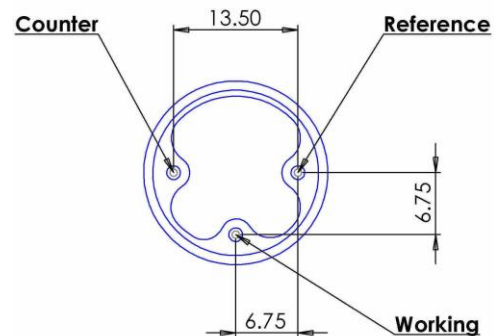
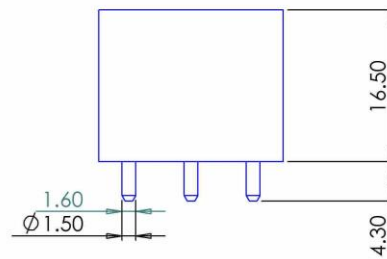
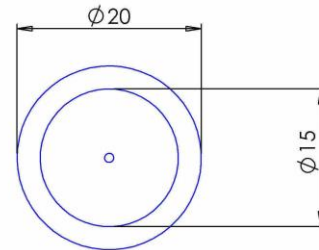

#### IMPORTANT NOTES

All performance is based on conditions at 20°C, 50% RH and 1 atm, using SGX recommended circuitry.

Sensor performance is temperature dependant; please contact SGX for temperature performance other than 20°C.

**Important Notes are continued on Page 2**

### IMPORTANT NOTES (Continued)

Do not solder to the connector pins as this may damage the sensor and thereby invalidate the warranty.

Details on recommended connector pins can be found in the Frequently Asked Questions within the Gas Sensor section of the SGX website.

### POISONING

SGX sensors are designed to operate in a wide range of harsh environments and conditions. However it is important that exposure to high concentrations of solvent vapours is avoided, both during storage, fitting into instrument and operation. When using sensors on printed circuit boards (PCBs), degreasing agents should be used prior to the sensor being fitted.

