

Programmable System Clock Chip for ATI RD790 - K8™ Based Systems 9LPRS477C

Recommended Application:

ATI RS780/RS790/RD790/RS880 systems using AMD K8 processors

Output Features:

- 2 - Greyhound compatible K8 CPU pair
- 6 - low-power differential SRC pairs
- 2 - low-power differential SouthBridge SRC pairs
- 4 - low-power differential ATIG pairs
- 1 - Selectable low-power differential 100MHz non-spread SATA/ SRC output
- 1 - Selectable 100MHz low-power differential/ 66 MHz single-ended HTT clock
- 2 - 48MHz USB clock
- 3 - 14.318MHz Reference clock

Key Specifications:

- CPU outputs cycle-to-cycle jitter < 85ps
- SRC outputs cycle-to-cycle jitter < 125ps
- ATIG outputs cycle-to-cycle jitter < 125ps
- +/- 300ppm frequency accuracy on CPU, SRC & ATIG clocks

Features/Benefits:

- CPU, ATIG, SB_SRC and SRC outputs are independently programmable for frequency
- Spread Spectrum for EMI reduction
- Outputs may be disabled via SMBus
- External crystal load capacitors for maximum frequency accuracy
- Meets PCIeX Gen2 specifications

Pin Configuration

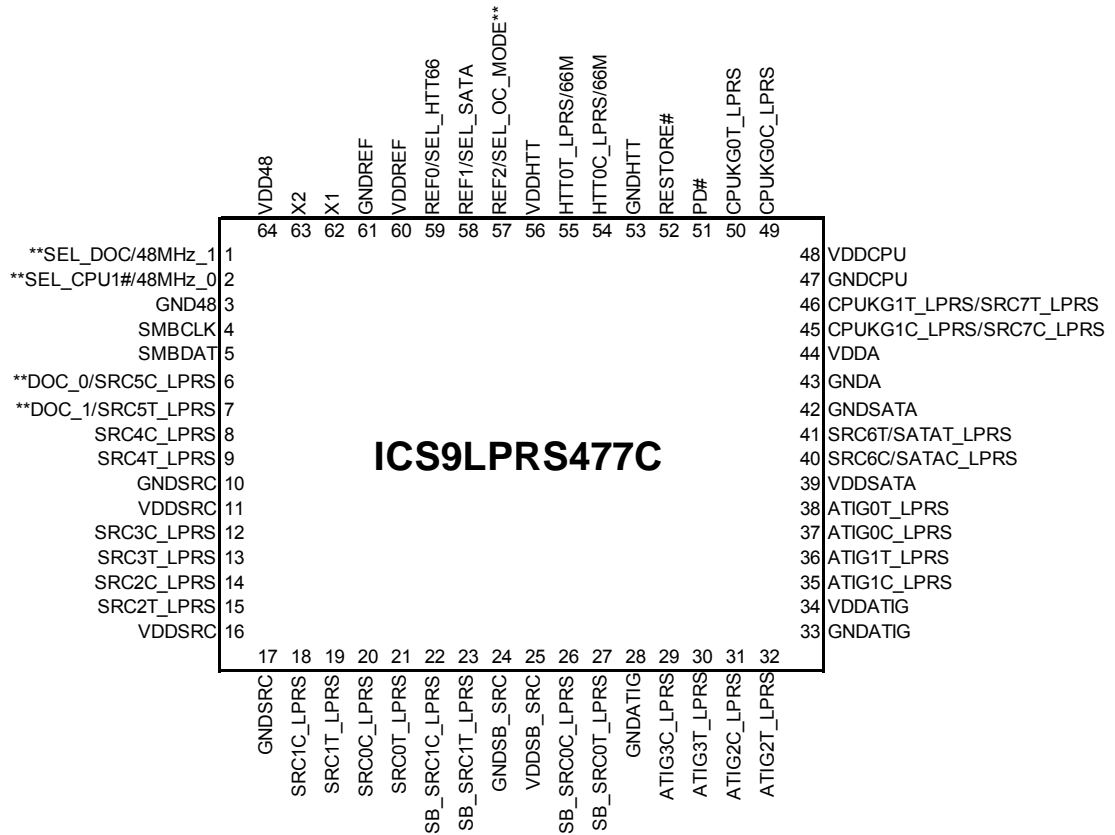

64-Pin VFQFPN

- * Internal Pull-Up Resistor
- ** Internal Pull-Down Resistor

VFQFPN Pin Description

PIN #	PIN NAME	PIN TYPE	DESCRIPTION
1	**SEL_DOC/48MHz_1	I/O	SEL_DOC: latched input to select pin functionality 1 = DOC input. 0 = SRCCLK5 / 48MHz clock output.
2	**SEL_CPU1#/48MHz_0	I/O	SEL_CPU1 latched input to select pin functionality 1 = SRCCLK7 0 = CPUKG1 / 48MHz clock output.
3	GND48	GND	Ground pin for the 48MHz outputs
4	SMBCLK	IN	Clock pin of SMBus circuitry, 5V tolerant.
5	SMBDAT	I/O	Data pin for SMBus circuitry, 5V tolerant.
6	**DOC_0/SRC5C_LPRS	OUT	Dynamic Over Clocking pin: real time frequency selection 0: Normal; 1: Frequency will transition to a preprogrammed value in the I2c. / Complement clock of low power differential SRC clock pair. (no 50ohm shunt resistor to GND and no 33 ohm series resistor needed)
7	**DOC_1/SRC5T_LPRS	OUT	Dynamic Over Clocking pin: real time frequency selection 0: Normal; 1: Frequency will transition to a preprogrammed value in the I2c. / True clock of low power differential SRC clock pair. (no 50ohm shunt resistor to GND and no 33 ohm series resistor needed)
8	SRC4C_LPRS	OUT	Complement clock of low power differential SouthBridge SRC clock pair. (no 50ohm shunt resistor to GND and no 33 ohm series resistor needed)
9	SRC4T_LPRS	OUT	True clock of low power differential SRC clock pair. (no 50ohm shunt resistor to GND and no 33 ohm series resistor needed)
10	GNDSRC	GND	Ground pin for the SRC outputs
11	VDDSRC	PWR	Supply for SRC core, 3.3V nominal
12	SRC3C_LPRS	OUT	Complement clock of low power differential SouthBridge SRC clock pair. (no 50ohm shunt resistor to GND and no 33 ohm series resistor needed)
13	SRC3T_LPRS	OUT	True clock of low power differential SRC clock pair. (no 50ohm shunt resistor to GND and no 33 ohm series resistor needed)
14	SRC2C_LPRS	OUT	Complement clock of low power differential SouthBridge SRC clock pair. (no 50ohm shunt resistor to GND and no 33 ohm series resistor needed)
15	SRC2T_LPRS	OUT	True clock of low power differential SRC clock pair. (no 50ohm shunt resistor to GND and no 33 ohm series resistor needed)
16	VDDSRC	PWR	Supply for SRC core, 3.3V nominal
17	GNDSRC	GND	Ground pin for the SRC outputs
18	SRC1C_LPRS	OUT	Complement clock of low power differential SouthBridge SRC clock pair. (no 50ohm shunt resistor to GND and no 33 ohm series resistor needed)
19	SRC1T_LPRS	OUT	True clock of low power differential SRC clock pair. (no 50ohm shunt resistor to GND and no 33 ohm series resistor needed)
20	SRC0C_LPRS	OUT	Complement clock of low power differential SouthBridge SRC clock pair. (no 50ohm shunt resistor to GND and no 33 ohm series resistor needed)
21	SRC0T_LPRS	OUT	True clock of low power differential SRC clock pair. (no 50ohm shunt resistor to GND and no 33 ohm series resistor needed)
22	SB_SRC1C_LPRS	OUT	Complement clock of low power differential SouthBridge SRC clock pair. (no 50ohm shunt resistor to GND and no 33 ohm series resistor needed)
23	SB_SRC1T_LPRS	OUT	True clock of low power differential SouthBridge SRC clock pair. (no 50ohm shunt resistor to GND and no 33 ohm series resistor needed)
24	GNDSB_SRC	GND	Ground pin for the SB_SRC outputs
25	VDDSB_SRC	PWR	Supply for SRC core, 3.3V nominal
26	SB_SRC0C_LPRS	OUT	Complement clock of low power differential SouthBridge SRC clock pair. (no 50ohm shunt resistor to GND and no 33 ohm series resistor needed)
27	SB_SRC0T_LPRS	OUT	True clock of low power differential SouthBridge SRC clock pair. (no 50ohm shunt resistor to GND and no 33 ohm series resistor needed)
28	GNDATIG	GND	Ground pin for the ATIG outputs
29	ATIG3C_LPRS	OUT	Complementary clock of low-power differential push-pull PCI-Express pair with integrated series resistor. (no 50ohm shunt resistor to GND and no 33 ohm series resistor needed)
30	ATIG3T_LPRS	OUT	True clock of low-power differential push-pull PCI-Express pair with integrated series resistor. (no 50ohm shunt resistor to GND and no 33 ohm series resistor needed)
31	ATIG2C_LPRS	OUT	Complementary clock of low-power differential push-pull PCI-Express pair with integrated series resistor. (no 50ohm shunt resistor to GND and no 33 ohm series resistor needed)
32	ATIG2T_LPRS	OUT	True clock of low-power differential push-pull PCI-Express pair with integrated series resistor. (no 50ohm shunt resistor to GND and no 33 ohm series resistor needed)

VFQFPN Pin Description (Continued)

PIN #	PIN NAME	PIN TYPE	DESCRIPTION
33	GNDATIG	GND	Ground pin for the ATIG outputs
34	VDDATIG	PWR	Power supply for ATIG core, nominal 3.3V
35	ATIG1C_LPRS	OUT	Complementary clock of low-power differential push-pull PCI-Express pair with integrated series resistor. (no 50ohm shunt resistor to GND and no 33 ohm series resistor needed)
36	ATIG1T_LPRS	OUT	True clock of low-power differential push-pull PCI-Express pair with integrated series resistor. (no 50ohm shunt resistor to GND and no 33 ohm series resistor needed)
37	ATIG0C_LPRS	OUT	Complementary clock of low-power differential push-pull PCI-Express pair with integrated series resistor. (no 50ohm shunt resistor to GND and no 33 ohm series resistor needed)
38	ATIG0T_LPRS	OUT	True clock of low-power differential push-pull PCI-Express pair with integrated series resistor. (no 50ohm shunt resistor to GND and no 33 ohm series resistor needed)
39	VDDSATA	PWR	Power supply for SATA core logic, nominal 3.3V
40	SRC6C/SATAC_LPRS	OUT	Complement clock of low power differential SRC/SATA clock pair. (no 50ohm shunt resistor to GND and no 33 ohm series resistor needed)
41	SRC6T/SATAT_LPRS	OUT	True clock of low power differential SRC/SATA clock pair. (no 50ohm shunt resistor to GND and no 33 ohm series resistor needed)
42	GNDSATA	GND	Ground pin for the SRC outputs
43	GNDA	GND	Ground for the Analog Core
44	VDDA	PWR	3.3V Power for the Analog Core
45	CPUKG1C_LPRS/SRC7C_LPRS	OUT	Complementary signal of low-power differential push-pull AMD K8 "Greyhound" clock with integrated series resistor. (no 33 ohm series resistor needed) / Complement clock of low power differential SRC clock pair. (no 50ohm shunt resistor to GND and no 33 ohm series resistor needed)
46	CPUKG1T_LPRS/SRC7T_LPRS	OUT	True signal of low-power differential push-pull AMD K8 "Greyhound" clock with integrated series resistor. (no 33 ohm series resistor needed) / True clock of low power differential SRC clock pair. (no 50ohm shunt resistor to GND and no 33 ohm series resistor needed)
47	GNDCPU	GND	Ground pin for the CPU outputs
48	VDDCPU	PWR	Supply for CPU core, 3.3V nominal
49	CPUKG0C_LPRS	OUT	Complementary signal of low-power differential push-pull AMD K8 "Greyhound" clock with integrated series resistor. (no 33 ohm series resistor needed)
50	CPUKG0T_LPRS	OUT	True signal of low-power differential push-pull AMD K8 "Greyhound" clock with integrated series resistor. (no 33 ohm series resistor needed)
51	PD#	IN	Enter /Exit Power Down. 0 = Power Down, 1 = normal operation.
52	RESTORE#	I/O	Open Drain I/O. As an input it restores the PLL's to power up default state. As an output, this signal is driven low when the internal watchdog hardware timer expires. It is cleared when the internal watchdog hardware timer is reset or disabled. The input is falling edge triggered. 0 = Restore Settings, 1 = normal operation.
53	GNDHTT	PWR	Ground pin for the HTT outputs
54	HTT0C_LPRS/66M	OUT	Complementary signal of low-power differential push-pull hypertransport clock with integrated series resistor. (no 50ohm shunt resistor to GND and no 33 ohm series resistor needed) / 3.3V single ended 66MHz hyper transport clock
55	HTT0T_LPRS/66M	OUT	True signal of low-power differential push-pull hypertransport clock with integrated series resistor. (no 50ohm shunt resistor to GND and no 33 ohm series resistor needed) / 3.3V single ended 66MHz hyper transport clock
56	VDDHTT	PWR	Supply for HTT clocks, nominal 3.3V.
57	REF2/SEL_OC_MODE**	I/O	14.318 MHz 3.3V reference clock / SEI_OC_MODE: latched input to select pin functionality 1 = ATIG/SRC PCIE Gen1 Mode with higher overclocking ability 0 = ATIG/SRC PCIE Gen2 Mode with limited overclocking ability
58	REF1/SEL_SATA	I/O	14.318 MHz 3.3V reference clock / 3.3V tolerant latched input to select function of SRC6/SATA output 0 = 100MHz differential spreading SRC clock, 1 = 100MHz non-spreading differential SATA clock
59	REF0/SEL_HTT66	I/O	14.318 MHz 3.3V reference clock / 3.3V tolerant latched input to select Hyper Transport Clock Frequency. 0 = 100MHz differential HTT clock, 1 = 66MHz 3.3V single ended HTT clock
60	VDDREF	PWR	Ref, XTAL power supply, nominal 3.3V
61	GNDREF	GND	Ground pin for the REF outputs.
62	X1	IN	Crystal input, nominally 14.318MHz
63	X2	OUT	Crystal output, nominally 14.318MHz
64	VDD48	PWR	Power pin for the 48MHz outputs and core. 3.3V

General Description

The **9LPRS477C** is a main clock synthesizer chip that provides all clocks required for ATI RD7xx-based systems using AMD processors. An SMBus interface allows full control of the device.

Block Diagram

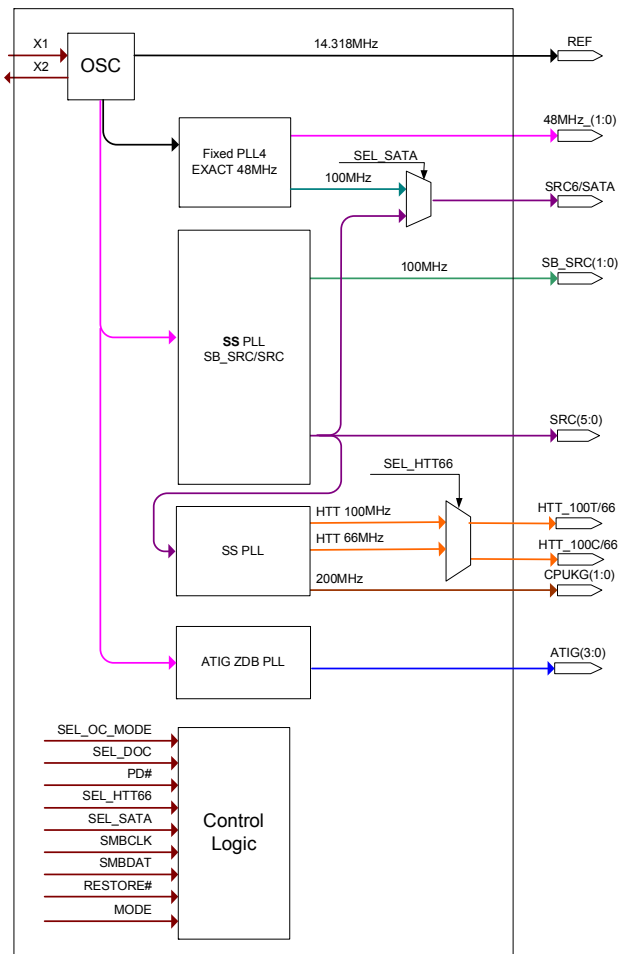

Power Groups

Pin Number		Description
VDD	GND	
64	3	USB_48 outputs
11, 16	10, 17	SRC differential outputs
25	24	SB_SRC differential outputs
39	42	SRC/SATA differential output
34	28,33	ATIG differential outputs
44	43	Analog, PLL
48	47	CPUKG differential outputs
56	53	HTTCLK output
60	61	REF outputs

Table1: CPU and HTT Frequency Selection Table

Byte 3					CPU (MHz)	HTT	HTT	Spread % (B6b6=1 and B3b5=1)	CPU OverClock %
Bit4	Bit3	Bit2	Bit1	Bit0		Single-	Differential		
CPU FS4	CPU FS3	CPU FS2	CPU FS1	CPU FS0		SEL_HTT66 = 1	SEL_HTT66 = 0		
0	0	0	0	0	200.00	66.67	100.00		0%
0	0	0	0	1	205.00	68.33	102.50		2%
0	0	0	1	0	210.00	70.00	105.00		5%
0	0	0	1	1	215.00	71.67	107.50		8%
0	0	1	0	0	220.00	73.33	110.00		10%
0	0	1	0	1	225.00	75.00	112.50		13%
0	0	1	1	0	230.00	76.67	115.00		15%
0	0	1	1	1	235.00	78.33	117.50		18%
0	1	0	0	0	240.00	80.00	120.00		20%
0	1	0	0	1	245.00	81.67	122.50		23%
0	1	0	1	0	250.00	83.33	125.00		25%
0	1	0	1	1	255.00	85.00	127.50		28%
0	1	1	0	0	260.00	86.67	130.00		30%
0	1	1	0	1	265.00	88.33	132.50		33%
0	1	1	1	0	270.00	90.00	135.00		35%
0	1	1	1	1	200.00	66.67	100.00		0%
1	0	0	0	0	280.00	93.33	140.00		40%
1	0	0	0	1	285.00	95.00	142.50		43%
1	0	0	1	0	290.00	96.67	145.00		45%
1	0	0	1	1	295.00	98.33	147.50		48%
1	0	1	0	0	300.00	100.00	150.00		50%
1	0	1	0	1	305.00	101.67	152.50		53%
1	0	1	1	0	310.00	103.33	155.00		55%
1	0	1	1	1	315.00	105.00	157.50		58%
1	1	0	0	0	320.00	106.67	160.00		60%
1	1	0	0	1	325.00	108.33	162.50		63%
1	1	0	1	0	330.00	110.00	165.00		65%
1	1	0	1	1	335.00	111.67	167.50		68%
1	1	1	0	0	340.00	113.33	170.00		70%
1	1	1	0	1	345.00	115.00	172.50		73%
1	1	1	1	0	350.00	116.67	175.00		75%
1	1	1	1	1	355.00	118.33	177.50		78%

Depends on SB_SRC_PLL. See Table 4.

Table 2: SRC Frequency Selection Table

B12b3	Byte 4				SRC (MHz)	Spread % (B6b5=1)	SRC OverClock %
	Bit3 SB FS3	Bit2 SB FS2	Bit1 SB FS1	Bit0 SB FS0			
0	0	0	0	0	100.00	-0.50%	0%
0	0	0	0	1	101.00		1%
0	0	0	1	0	102.00		2%
0	0	0	1	1	103.00		3%
0	0	1	0	0	104.00		4%
0	0	1	0	1	105.00		5%
0	0	1	1	0	106.00		6%
0	0	1	1	1	107.00		7%
0	1	0	0	0	108.00		8%
0	1	0	0	1	109.00		9%
0	1	0	1	0	110.00		10%
0	1	0	1	1	111.00		11%
0	1	1	0	0	112.00		12%
0	1	1	0	1	113.00		13%
0	1	1	1	0	114.00		14%
0	1	1	1	1	100.00	OFF	0%
1	0	0	0	0	100.00	-0.50%	0%
1	0	0	0	1	101.00		1%
1	0	0	1	0	102.00		2%
1	0	0	1	1	103.00		3%
1	0	1	0	0	104.00		4%
1	0	1	0	1	105.00		5%
1	0	1	1	0	106.00		6%
1	0	1	1	1	107.00		7%
1	1	0	0	0	108.00		8%
1	1	0	0	1	109.00		9%
1	1	0	1	0	110.00		10%
1	1	0	1	1	111.00		11%
1	1	1	0	0	112.00		12%
1	1	1	0	1	113.00		13%
1	1	1	1	0	114.00		14%
1	1	1	1	1	100.00	OFF	0%

Table3: ATIG Frequency Selection Table

B12b3	Byte 5				ATIG(3:0) (MHz)	Spread % (B6b7=1)	ATIG OverClock %
	Bit3 ATIG FS3	Bit2 ATIG FS2	Bit1 ATIG FS1	Bit0 ATIG FS0			
0	0	0	0	0	100.00	-0.50%	0%
0	0	0	0	1	101.00		1%
0	0	0	1	0	102.00		2%
0	0	0	1	1	103.00		3%
0	0	1	0	0	104.00		4%
0	0	1	0	1	105.00		5%
0	0	1	1	0	106.00		6%
0	0	1	1	1	107.00		7%
0	1	0	0	0	108.00		8%
0	1	0	0	1	109.00		9%
0	1	0	1	0	110.00		10%
0	1	0	1	1	111.00		11%
0	1	1	0	0	112.00		12%
0	1	1	0	1	113.00		13%
0	1	1	1	0	114.00		14%
0	1	1	1	1	100.00		OFF
1	0	0	0	0	100.00	-0.50%	0%
1	0	0	0	1	101.00		1%
1	0	0	1	0	102.00		2%
1	0	0	1	1	103.00		3%
1	0	1	0	0	104.00		4%
1	0	1	0	1	105.00		5%
1	0	1	1	0	106.00		6%
1	0	1	1	1	107.00		7%
1	1	0	0	0	108.00		8%
1	1	0	0	1	109.00		9%
1	1	0	1	0	110.00		10%
1	1	0	1	1	111.00		11%
1	1	1	0	0	112.00		12%
1	1	1	0	1	113.00		13%
1	1	1	1	0	114.00		14%
1	1	1	1	1	100.00		OFF

Table4: SB_SRC Frequency Selection Table

Byte 6					SB_SRC (1:0) (MHz)	Spread % (B6b6=1)	SB_SRC OverClock %
Bit4	Bit3	Bit2	Bit1	Bit0			
SRC FS4	SRC FS3	SRC FS2	SRC FS1	SRC FS0			
0	0	0	0	0	85.00	-0.50%	-15%
0	0	0	0	1	86.00		-14%
0	0	0	1	0	87.00		-13%
0	0	0	1	1	88.00		-12%
0	0	1	0	0	89.00		-11%
0	0	1	0	1	90.00		-10%
0	0	1	1	0	91.00		-9%
0	0	1	1	1	92.00		-8%
0	1	0	0	0	93.00		-7%
0	1	0	0	1	94.00		-6%
0	1	0	1	0	95.00		-5%
0	1	0	1	1	96.00		-4%
0	1	1	0	0	97.00		-3%
0	1	1	0	1	98.00		-2%
0	1	1	1	0	99.00		-1%
0	1	1	1	1	100.00		OFF
1	0	0	0	0	100.00	-0.50%	0%
1	0	0	0	1	101.00		1%
1	0	0	1	0	102.00		2%
1	0	0	1	1	103.00		3%
1	0	1	0	0	104.00		4%
1	0	1	0	1	105.00		5%
1	0	1	1	0	106.00		6%
1	0	1	1	1	107.00		7%
1	1	0	0	0	108.00		8%
1	1	0	0	1	109.00		9%
1	1	0	1	0	110.00		10%
1	1	0	1	1	111.00		11%
1	1	1	0	0	112.00		12%
1	1	1	0	1	113.00		13%
1	1	1	1	0	114.00		14%
1	1	1	1	1	115.00		15%

NOTE: All frequencies assume that the SB_SRC are at 0% Overclocking.

Table 5: IO_Vout select table

B12b2	B12b1	B12b0	IO_Vout
0	0	0	0.3V
0	0	1	0.4V
0	1	0	0.5V
0	1	1	0.6V
1	0	0	0.7V
1	0	1	0.8V
1	1	0	0.9V
1	1	1	1.0V

Bold Entry is Power up Default

General SMBus serial interface information for the 9LPRS477C

How to Write:

- Controller (host) sends a start bit.
- Controller (host) sends the write address D2_(H)
- ICS clock will **acknowledge**
- Controller (host) sends the beginning byte location = N
- ICS clock will **acknowledge**
- Controller (host) sends the data byte count = X
- ICS clock will **acknowledge**
- Controller (host) starts sending **Byte N through Byte N + X - 1**
- ICS clock will **acknowledge** each byte **one at a time**
- Controller (host) sends a Stop bit

How to Read:

- Controller (host) will send start bit.
- Controller (host) sends the write address D2_(H)
- ICS clock will **acknowledge**
- Controller (host) sends the beginning byte location = N
- ICS clock will **acknowledge**
- Controller (host) will send a separate start bit.
- Controller (host) sends the read address D3_(H)
- ICS clock will **acknowledge**
- ICS clock will send the data byte count = X
- ICS clock sends **Byte N + X - 1**
- ICS clock sends **Byte 0 through byte X (if X_(H) was written to byte 8).**
- Controller (host) will need to acknowledge each byte
- Controller (host) will send a not acknowledge bit
- Controller (host) will send a stop bit

Index Block Write Operation		
Controller (Host)		ICS (Slave/Receiver)
T	starT bit	
Slave Address *D0 _(H)		
WR	WRite	
		ACK
Beginning Byte = N		
		ACK
Data Byte Count = X		
		ACK
Beginning Byte N		X Byte
	◇	
	◇	
	◇	
	◇	
Byte N + X - 1		
		ACK
P	stoP bit	

Index Block Read Operation		
Controller (Host)		ICS (Slave/Receiver)
T	starT bit	
Slave Address *D0 _(H)		
WR	WRite	
		ACK
Beginning Byte = N		
		ACK
RT	Repeat starT	
Slave Address *D1 _(H)		
RD	ReaD	
		ACK
		Data Byte Count = X
ACK		
		X Byte
ACK		
◇		
◇		
		Beginning Byte N
		◇
		◇
		◇
		Byte N + X - 1
N	Not acknowledge	
P	stoP bit	

SMBus Table: Latched Input Readback Output Enable Control Register

Byte	0	Name	Description	Type	0	1	Default
Bit 7	SEL_HTT66 readback	Hypertransport Select	R	100MHz Differential HTT clock	66 MHz 3.3V Single-ended HTT clock	Latch	
Bit 6	SEL_SATA readback	SATA Select	R	SRC6/SATA pair is SRC SS capable output	SRC6/SATA pair is SATA non-spread output	Latch	
Bit 5	REF0_OE	Output Enable	RW	Hi-Z	Enabled	1	
Bit 4	REF1_OE	Output Enable	RW	Hi-Z	Enabled	1	
Bit 3	REF2_OE	Output Enable	RW	Hi-Z	Enabled	1	
Bit 2	48MHz_1_OE	Output Enable	RW	Low	Enabled	1	
Bit 1	48MHz_0_OE	Output Enable	RW	Low	Enabled	1	
Bit 0	SEL_CPU1 readback	CPU1/SRC7 Select	R	CPU1 Differential output	SRC7 Differential output	Latch	

SMBus Table: Output Enable Control Register

Byte	1	Name	Control Function	Type	0	1	Default
Bit 7	SEL_DOC readback	DOC Select	R	SRC5 Differential output	DOC	Latch	
Bit 6	SRC6/SATA_OE Enable	Output Enable	RW	Low/Low	Enabled	1	
Bit 5	SRC5_OE	Output Enable	RW	Low/Low	Enabled	1	
Bit 4	SRC4_OE	Output Enable	RW	Low/Low	Enabled	1	
Bit 3	SRC3_OE	Output Enable	RW	Low/Low	Enabled	1	
Bit 2	SRC2_OE	Output Enable	RW	Low/Low	Enabled	1	
Bit 1	SRC1_OE	Output Enable	RW	Low/Low	Enabled	1	
Bit 0	SRC0_OE	Output Enable	RW	Low/Low	Enabled	1	

SMBus Table: Output Enable and 48MHz Strength Control Register

Byte	2	Name	Control Function	Type	0	1	Default
Bit 7	SB_SRC1_OE	Output Enable	RW	Low/Low	Enabled	1	
Bit 6	SB_SRC0_OE	Output Enable	RW	Low/Low	Enabled	1	
Bit 5	ATIG3_OE	Output Enable	RW	Low/Low	Enabled	1	
Bit 4	ATIG2_OE	Output Enable	RW	Low/Low	Enabled	1	
Bit 3	ATIG1_OE	Output Enable	RW	Low/Low	Enabled	1	
Bit 2	ATIG0_OE	Output Enable	RW	Low/Low	Enabled	1	
Bit 1	48MHz_1_Strength	48MHz_1 Drive Strength Sel.	RW	1 Load	2 Load	1	
Bit 0	48MHz_0_Strength	48MHz_0 Drive Strength Sel.	RW	1 Load	2 Load	1	

SMBus Table: CPU/HTT Frequency Control Register

Byte	3	Name	Control Function	Type	0	1	Default
Bit 7	CPU1_OE/SRC7_OE	Output enable	RW	Low/Low	Enable	1	
Bit 6	CPU0_OE	Output enable	RW	Low/Low	Enable	1	
Bit 5	CPU Spread Source	CPU Spread Source	RW	Fix PLL	SB_SRC PLL	1	
Bit 4	CPU_FS4	CPU Frequency Select MSB	RW	See CPU Frequency Select Table Default value corresponds to 200MHz. Note that Selected HTT frequency tracks the CPU frequency.		0	
Bit 3	CPU_FS3	CPU Frequency Select	RW			1	
Bit 2	CPU_FS2	CPU Frequency Select	RW			1	
Bit 1	CPU_FS1	CPU Frequency Select	RW			1	
Bit 0	CPU_FS0	CPU Frequency Select LSB	RW			1	

SMBus Table: SRC Frequency Control Register

Byte	4	Name	Control Function	Type	0	1	Default
Bit 7	REF0_Strength	REF0_Drive Strength Sel	RW	1 Load	2 Load	1	
Bit 6	REF1_Strength	REF1_Drive Strength Sel	RW	1 Load	2 Load	1	
Bit 5	REF2_Strength	REF2_Drive Strength Sel	RW	1 Load	2 Load	1	
Bit 4		Reserved				0	
Bit 3	SRC_FS3	SRC Frequency Select	RW	See SRC Frequency Select Table		1	
Bit 2	SRC_FS2	SRC Frequency Select	RW			1	
Bit 1	SRC_FS1	SRC Frequency Select	RW			1	
Bit 0	SRC_FS0	SRC Frequency Select LSB	RW			1	

SMBus Table: ATIG Frequency Select Register

Byte	5	Name	Control Function	Type	0	1	Default
Bit 7		ATIG PLL TBEN	ATIG PLL Turbo Enable	RW	Disable	Enable	0
Bit 6		CPU PLL TBEN	CPU PLL Turbo Enable	RW	Disable	Enable	0
Bit 5		SRC PLL TBEN	SRC PLL Turbo Enable	RW	Disable	Enable	0
Bit 4		DISABLE_OR_T	Disable Overshoot Reduction Technology during CPU PLL M/N Programming	RW	ENABLE ORT	DISABLE ORT	0
Bit 3		ATIG_FS3	ATIG Frequency Select	RW	See ATIG Frequency Select Table		1
Bit 2		ATIG_FS2	ATIG Frequency Select	RW			1
Bit 1		ATIG_FS1	ATIG Frequency Select	RW			1
Bit 0		ATIG_FS0	ATIG Frequency Select LSB	RW			1

SMBus Table: SB_SRC Frequency Select Register

Byte	6	Name	Control Function	Type	0	1	Default
Bit 7		ATIG SSEN	ATIG Spread Enable	RW	Disable	Enable	0
Bit 6		SB_SRC/CPU SSEN	SB_SRC/CPU Spread Enable	RW	Disable	Enable	0
Bit 5		SRC SSEN	SRC Spread Enable	RW	Disable	Enable	0
Bit 4		SB_SRC_FS4	SB_SRC Frequency Select MSB	RW	See SB_SRC Frequency Select Table Note: SB_SRC and CPU Clocks are synchronous. Changing this frequency will alter the SB_SRC and CPU frequency by the same percentage.		0
Bit 3		SB_SRC_FS3	SB_SRC Frequency Select	RW			1
Bit 2		SB_SRC_FS2	SB_SRC Frequency Select	RW			1
Bit 1		SB_SRC_FS1	SB_SRC Frequency Select	RW			1
Bit 0		SB_SRC_FS0	SB_SRC Frequency Select LSB	RW			1

SMBus Table: Device ID register

Byte	7	Name	Control Function	Type	0	1	Default
Bit 7		Device ID7	Device ID	R	75 hex for 9LPRS477		x
Bit 6		Device ID6		R			x
Bit 5		Device ID5		R			x
Bit 4		Device ID4		R			x
Bit 3		Device ID3		R			x
Bit 2		Device ID2		R			x
Bit 1		Device ID1		R			x
Bit 0		Device ID0		R			x

SMBus Table: Vendor & Revision ID Register

Byte	8	Name	Control Function	Type	0	1	Default
Bit 7		RID3	REVISION ID	R	-	-	0
Bit 6		RID2		R	-	-	0
Bit 5		RID1		R	-	-	1
Bit 4		RID0		R	-	-	1
Bit 3		VID3	VENDOR ID	R	-	-	0
Bit 2		VID2		R	-	-	0
Bit 1		VID1		R	-	-	0
Bit 0		VID0		R	-	-	1

SMBus Table: WatchDog Timer Control Register

Byte	9	Name	Control Function	Type	0	1	Default
Bit 7		HWD_EN	Watchdog Hard Alarm Enable	RW	Disable and Reload Hardt Alarm Timer, Clear WD Hard status bit.	Enable Timer	0
Bit 6		SWD_EN	Watchdog Soft Alarm Enable	RW	Disable	Enable	0
Bit 5		WD Hard Status	WD Hard Alarm Status	R	Normal	Alarm	X
Bit 4		WD Soft Status	WD Soft Alarm Status	R	Normal	Alarm	X
Bit 3		WDTCtrl	Watch Dog Alarm Time base Control	RW	290ms Base	1160ms Base	0
Bit 2		HWD2	WD Hard Alarm Timer Bit 2	RW	These bits represent the number of Watch Dog Time Base Units that pass before the Watch Alarm expires. Default is 7 X 290ms = 2s.		1
Bit 1		HWD1	WD Hard Alarm Timer Bit 1	RW			1
Bit 0		HWD0	WD Hard Alarm Timer Bit 0	RW			1

SMBus Table: WD Timer Safe Frequency Control Register

Byte	10	Name	Control Function	Type	0	1	Default
Bit 7		SWD2	WD Soft Alarm Timer Bit 2	RW	These bits represent the number of Watch Dog Time Base Units that pass before the Watch Alarm expires. Default is 7 X 290ms = 2s.		1
Bit 6		SWD1	WD Soft Alarm Timer Bit 1	RW			1
Bit 5		SWD0	WD Soft Alarm Timer Bit 0	RW			1
Bit 4		WD SF4	Watch Dog Safe Freq Programming bits	RW	These bits configure the safe frequency that the device returns to if the Watchdog Timer expires. The value show here corresponds to the power up default of the device. See the various Frequency Select Tables for the exact frequencies.		0
Bit 3		WD SF3		RW			1
Bit 2		WD SF2		RW			1
Bit 1		WD SF1		RW			1
Bit 0		WD SF0		RW			1

SMBus Table: Byte Count Register

Byte	11	Name	Control Function	Type	0	1	Default
Bit 7					Reserved		0
Bit 6					Reserved		0
Bit 5		BC5	Byte Count bit 5 (MSB)	RW	Determines the number of bytes that are read back from the device. Default is 0F hex.		0
Bit 4		BC4	Byte Count bit 4	RW			0
Bit 3		BC3	Byte Count bit 3	RW			1
Bit 2		BC2	Byte Count bit 2	RW			1
Bit 1		BC1	Byte Count bit 1	RW			1
Bit 0		BC0	Byte Count bit 0 (LSB)	RW			1

SMBus Table: M/N Programming Enable and I/O Vout Control Register

Byte	12	Name	Control Function	Type	0	1	Default
Bit 7		CPU M/N En	CPU PLL M/N Prog. Enable	RW	M/N Prog. Disabled	M/N Prog. Enabled	0
Bit 6		SRC M/N En	SRC M/N Prog. Enable	RW	M/N Prog. Disabled	M/N Prog. Enabled	0
Bit 5		ATIG M/N En	ATIG M/N Prog. Enable	RW	M/N Prog. Disabled	M/N Prog. Enabled	0
Bit 4		SB_SRC M/N En	SB_SRC M/N Prog. Enable	RW	M/N Prog. Disabled	M/N Prog. Enabled	0
Bit 3		SEL_OC_MODE readback	OC MODE Select	R	PCIe Gen2 Mode	PCIe Gen1 Mode	Latch
Bit 2		IO_VOUT2	IO Output Voltage Select (Most Significant Bit)	RW	See Table 5: V_IO Selection (Default is 0.8V)		1
Bit 1		IO_VOUT1	IO Output Voltage Select	RW			0
Bit 0		IO_VOUT0	IO Output Voltage Select (Least Significant Bit)	RW			1

Bytes 13/14 are reserved

SMBus Table: Test Mode Register

Byte	15	Name	Control Function	Type	0	1	Default
Bit 7		Test_Sel	Selects Test Mode	RW	Normal mode	All outputs are REF/N	0
Bit 6		SB_SRC_Source	SB_SRC Source Selection	RW	SB_SRC PLL	SRC PLL	1
Bit 5		ATIG PLL	ATIG PLL DOC pin control	RW	DOC0	DOC1	0
Bit 4		CPU PLL	CPU PLL DOC pin control	RW	DOC0	DOC1	0
Bit 3		SRC PLL	SRC PLL DOC pin control	RW	DOC0	DOC1	0
Bit 2		ATIG PLL	ATIG PLL DOC0 2 pin control	RW	Disable	Enable	0
Bit 1		CPU PLL	CPU PLL DOC0 2 pin control	RW	Disable	Enable	0
Bit 0		SRC PLL	SRC PLL DOC0 2 pin control	RW	Disable	Enable	0

SMBus Table: CPU PLL Frequency Control Register

Byte	16	Name	Control Function	Type	0	1	Default
Bit 7		N Div2	N Divider Prog bit 2	RW	The decimal representation of M and N Divider in Byte 16 and 17 will configure the VCO frequency. Default at power up = Byte 3 Rom table. See M/N Calculation Tables for VCO frequency formulas.		X
Bit 6		N Div1	N Divider Prog bit 1	RW			X
Bit 5		M Div5	M Divider Programming bits	RW			X
Bit 4		M Div4		RW			X
Bit 3		M Div3		RW			X
Bit 2		M Div2		RW			X
Bit 1		M Div1		RW			X
Bit 0		M Div0		RW			X

SMBus Table: CPU PLL Frequency Control Register

Byte	17	Name	Control Function	Type	0	1	Default
Bit 7		N Div10	N Divider Programming b(10:3)	RW	The decimal representation of M and N Divider in Byte 16 and 17 will configure the VCO frequency. Default at power up = Byte 3 Rom table. See M/N Calculation Tables for VCO frequency formulas.		X
Bit 6		N Div9		RW			X
Bit 5		N Div8		RW			X
Bit 4		N Div7		RW			X
Bit 3		N Div6		RW			X
Bit 2		N Div5		RW			X
Bit 1		N Div4		RW			X
Bit 0		N Div3		RW			X

SMBus Table: SB_SRC PLL Spread Spectrum Control Register

Byte	18	Name	Control Function	Type	0	1	Default
Bit 7		SSP7	Spread Spectrum Programming b(7:0)	RW	These bits set the SB_SRC spread percentage. Please contact IDT for the appropriate values.		X
Bit 6		SSP6		RW			X
Bit 5		SSP5		RW			X
Bit 4		SSP4		RW			X
Bit 3		SSP3		RW			X
Bit 2		SSP2		RW			X
Bit 1		SSP1		RW			X
Bit 0		SSP0		RW			X

SMBus Table: SB_SRC PLL Spread Spectrum Control Register

Byte	19	Name	Control Function	Type	0	1	Default
Bit 7		SSP15	Spread Spectrum Programming b(15:8)	RW	These bits set the SB_SRC spread percentage. Please contact IDT for the appropriate values.		X
Bit 6		SSP14		RW			X
Bit 5		SSP13		RW			X
Bit 4		SSP12		RW			X
Bit 3		SSP11		RW			X
Bit 2		SSP10		RW			X
Bit 1		SSP9		RW			X
Bit 0		SSP8		RW			X

SMBUS Table: CPU Output Divider Register

Byte	20	Name	Control Function	Type	0	1	Default
Bit 7		CPU NDiv0	LSB N Divider Programming	RW	Byte 28 has the N Divider LSB (bit 0) for CPU M/N programming.		X
Bit 6			Reserved				X
Bit 5			Reserved				X
Bit 4			Reserved				X
Bit 3		CPUDiv3	CPU Divider Ratio Programming Bits	RW	0000:/2 ; 0100:/4	1000:/8 ; 1100:/16	X
Bit 2		CPUDiv2		RW	0001:/3 ; 0101:/6	1001:/12 ; 1101:/24	X
Bit 1		CPUDiv1		RW	0010:/5 ; 0110:/10	1010:/20 ; 1110:/40	X
Bit 0		CPUDiv0		RW	0011:/9 ; 0111:/18	1011:/36 ; 1111:/72	X

SMBUS Table: SRC Frequency Control Register

Byte	21	Name	Control Function	Type	0	1	Default
Bit 7		N Div2	N Divider Prog bit 2	RW	The decimal representation of M and N Divider in Byte 21 and 22 configure the SRC VCO frequency. See M/N Calculation Tables for VCO frequency formulas.		X
Bit 6		N Div1	N Divider Prog bit 1	RW			X
Bit 5		M Div5	M Divider Programming bit (5:0)	RW			X
Bit 4		M Div4		RW			X
Bit 3		M Div3		RW			X
Bit 2		M Div2		RW			X
Bit 1		M Div1		RW			X
Bit 0		M Div0		RW			X

SMBUS Table: SRC Frequency Control Register

Byte	22	Name	Control Function	Type	0	1	Default
Bit 7		N Div10	N Divider Programming Byte16 bit(7:0) and Byte15 bit(7:6)	RW	The decimal representation of M and N Divider in Byte 21 and 22 configure the SRC VCO frequency. See M/N Calculation Tables for VCO frequency formulas.		X
Bit 6		N Div9		RW			X
Bit 5		N Div8		RW			X
Bit 4		N Div7		RW			X
Bit 3		N Div6		RW			X
Bit 2		N Div5		RW			X
Bit 1		N Div4		RW			X
Bit 0		N Div3		RW			X

SMBUS Table: SRC Spread Spectrum Control Register

Byte	23	Name	Control Function	Type	0	1	Default
Bit 7		SSP7	Spread Spectrum Programming bit(7:0)	RW	These bits set the SRC spread percentages. Please contact IDT for the appropriate values.		X
Bit 6		SSP6		RW			X
Bit 5		SSP5		RW			X
Bit 4		SSP4		RW			X
Bit 3		SSP3		RW			X
Bit 2		SSP2		RW			X
Bit 1		SSP1		RW			X
Bit 0		SSP0		RW			X

SMBUS Table: SRC Spread Spectrum Control Register

Byte	24	Name	Control Function	Type	0	1	Default
Bit 7		SSP15	Spread Spectrum Programming bit(15:8)	RW	These bits set the SRC spread percentages. Please contact IDT for the appropriate values.		X
Bit 6		SSP14		RW			X
Bit 5		SSP13		RW			X
Bit 4		SSP12		RW			X
Bit 3		SSP11		RW			X
Bit 2		SSP10		RW			X
Bit 1		SSP9		RW			X
Bit 0		SSP8		RW			X

SMBUS Table: SRC Output Divider Control Register

Byte	25	Name	Control Function	Type	0	1	Default
Bit 7		SB_SRC NDiv0	LSB N Divider Programming	RW	N Divider LSB (bit 0) for SRC MN programming.		X
Bit 6			Reserved				X
Bit 5			Reserved				X
Bit 4			Reserved				X
Bit 3		SRCDiv3	SRC Divider Ratio Programming Bits	RW	0000:/2 ; 0100:/4	1000:/8 ; 1100:/16	X
Bit 2		SRCDiv2		RW	0001:/3 ; 0101:/6	1001:/12 ; 1101:/24	X
Bit 1		SRCDiv1		RW	0010:/5 ; 0110:/10	1010:/20 ; 1110:/40	X
Bit 0		SRCDiv0		RW	0011:/9 ; 0111:/18	1011:/36 ; 1111:/72	X

SMBUS Table: ATIG Frequency Control Register

Byte	26	Name	Control Function	Type	0	1	Default
Bit 7		N Div2	N Divider Prog bit 2	RW	The decimal representation of M and N Divider in Byte 26 and 27 will configure the VCO frequency. Default at power up = Byte 5 Rom table. See MN Calculation Tables for VCO frequency formulas.		X
Bit 6		N Div1	N Divider Prog bit 1	RW			X
Bit 5		M Div5	M Divider Programming bit (5:0)	RW			X
Bit 4		M Div4		RW			X
Bit 3		M Div3		RW			X
Bit 2		M Div2		RW			X
Bit 1		M Div1		RW			X
Bit 0		M Div0		RW			X

SMBUS Table: ATIG Frequency Control Register

Byte	27	Name	Control Function	Type	0	1	Default
Bit 7		N Div10	N Divider Programming Byte20 bit(7:0) and Byte19 bit(7:6)	RW	The decimal representation of M and N Divider in Byte 26 and 27 will configure the VCO frequency. Default at power up = Byte 5 Rom table. See MN Calculation Tables for VCO frequency formulas.		X
Bit 6		N Div9		RW			X
Bit 5		N Div8		RW			X
Bit 4		N Div7		RW			X
Bit 3		N Div6		RW			X
Bit 2		N Div5		RW			X
Bit 1		N Div4		RW			X
Bit 0		N Div3		RW			X

SMBUS Table: ATIG Output Divider Control Register

Byte	28	Name	Control Function	Type	0	1	Default
Bit 7		ATIG NDiv0	LSB N Divider Programming	RW	N Divider LSB (bit 0) for ATIG MN programming.		X
Bit 6					Reserved		X
Bit 5					Reserved		X
Bit 4					Reserved		X
Bit 3		ATIGDiv3	ATIG Divider Ratio Programming Bits	RW	0000:/2 ; 0100:/4	1000:/8 ; 1100:/16	X
Bit 2		ATIGDiv2		RW	0001:/3 ; 0101:/6	1001:/12 ; 1101:/24	X
Bit 1		ATIGDiv1		RW	0010:/5 ; 0110:/10	1010:/20 ; 1110:/40	X
Bit 0		ATIGDiv0		RW	0011:/9 ; 0111:/18	1011:/36 ; 1111:/72	X

SMBUS Table: SB_SRC Frequency Control Register

Byte	29	Name	Control Function	Type	0	1	Default
Bit 7		N Div2	N Divider Prog bit 2	RW	The decimal representation of M and N Divider in Byte 29 and 30 will configure the VCO frequency. Default at power up = Byte 6 Rom table. See MN Calculation Tables for VCO frequency formulas.		X
Bit 6		N Div1	N Divider Prog bit 1	RW			X
Bit 5		M Div5	M Divider Programming bit (5:0)	RW			X
Bit 4		M Div4		RW			X
Bit 3		M Div3		RW			X
Bit 2		M Div2		RW			X
Bit 1		M Div1		RW			X
Bit 0		M Div0		RW			X

SMBUS Table: SB_SRC Frequency Control Register

Byte	30	Name	Control Function	Type	0	1	Default
Bit 7		N Div10	N Divider Programming Byte20 bit(7:0) and Byte19 bit(7:6)	RW	The decimal representation of M and N Divider in Byte 29 and 30 will configure the VCO frequency. Default at power up = Byte 6 Rom table. See MN Calculation Tables for VCO frequency formulas.		X
Bit 6		N Div9		RW			X
Bit 5		N Div8		RW			X
Bit 4		N Div7		RW			X
Bit 3		N Div6		RW			X
Bit 2		N Div5		RW			X
Bit 1		N Div4		RW			X
Bit 0		N Div3		RW			X

SMBUS Table: SB_SRC Output Divider Control Register

Byte	31	Name	Control Function	Type	0	1	Default
Bit 7		SB_SRC NDiv0	LSB N Divider Programming	RW	N Divider LSB (bit 0) for SRC MN programming.		X
Bit 6					Reserved		X
Bit 5					Reserved		X
Bit 4					Reserved		X
Bit 3		SB_SRCDiv3	SB_SRC Divider Ratio Programming Bits	RW	0000:/2 ; 0100:/4	1000:/8 ; 1100:/16	X
Bit 2		SB_SRCDiv2		RW	0001:/3 ; 0101:/6	1001:/12 ; 1101:/24	X
Bit 1		SB_SRCDiv1		RW	0010:/5 ; 0110:/10	1010:/20 ; 1110:/40	X
Bit 0		SB_SRCDiv0		RW	0011:/9 ; 0111:/18	1011:/36 ; 1111:/72	X

SMBUS Table: CPU PLL DOC 1 N programming Register (1 pin control : DOC = 1; 2 pin control : DOC [0:1] = 01)

Byte	32	Name	Control Function	Type	0	1	Default
Bit 7		N Div10	N Divider Programming Byte20 bit(7:0) and Byte19 bit(7:6)	RW	The decimal representation of M and N Divider in Byte 16 and 32 will configure the VCO frequency. Default at power up = Byte 3 Rom table. See MN Calculation Tables for VCO frequency formulas.		X
Bit 6		N Div9		RW			X
Bit 5		N Div8		RW			X
Bit 4		N Div7		RW			X
Bit 3		N Div6		RW			X
Bit 2		N Div5		RW			X
Bit 1		N Div4		RW			X
Bit 0		N Div3		RW			X

SMBUS Table: CPU PLL DOC 2 N programming Register (1 pin control : DOC = 1; 2 pin control : DOC [0:1] = 10)

Byte	33	Name	Control Function	Type	0	1	Default
Bit 7		N Div10	N Divider Programming Byte20 bit(7:0) and Byte19 bit(7:6)	RW	The decimal representation of M and N Divider in Byte 16 and 33 will configure the VCO frequency. Default at power up = Byte 3 Rom table. See MN Calculation Tables for VCO frequency formulas.		X
Bit 6		N Div9		RW			X
Bit 5		N Div8		RW			X
Bit 4		N Div7		RW			X
Bit 3		N Div6		RW			X
Bit 2		N Div5		RW			X
Bit 1		N Div4		RW			X
Bit 0		N Div3		RW			X

SMBUS Table: CPU PLL DOC 3 N programming Register (1 pin control : DOC = 1; 2 pin control : DOC [0:1] = 11)

Byte	34	Name	Control Function	Type	0	1	Default
Bit 7		N Div10	N Divider Programming Byte20 bit(7:0) and Byte19 bit(7:6)	RW	The decimal representation of M and N Divider in Byte 16 and 34 will configure the VCO frequency. Default at power up = Byte 3 Rom table. See MN Calculation Tables for VCO frequency formulas.		X
Bit 6		N Div9		RW			X
Bit 5		N Div8		RW			X
Bit 4		N Div7		RW			X
Bit 3		N Div6		RW			X
Bit 2		N Div5		RW			X
Bit 1		N Div4		RW			X
Bit 0		N Div3		RW			X

SMBUS Table: ATIG PLL DOC 1 N programming Register (1 pin control : DOC = 1; 2 pin control : DOC [0:1] = 01)

Byte	35	Name	Control Function	Type	0	1	Default
Bit 7		N Div10	N Divider Programming Byte20 bit(7:0) and Byte19 bit(7:6)	RW	The decimal representation of M and N Divider in Byte 26 and 35 will configure the VCO frequency. Default at power up = Byte 5 Rom table. See MN Calculation Tables for VCO frequency formulas.		X
Bit 6		N Div9		RW			X
Bit 5		N Div8		RW			X
Bit 4		N Div7		RW			X
Bit 3		N Div6		RW			X
Bit 2		N Div5		RW			X
Bit 1		N Div4		RW			X
Bit 0		N Div3		RW			X

SMBUS Table: ATIG PLL DOC 2 N programming Register (1 pin control : DOC = 1; 2 pin control : DOC [0:1] = 10)

Byte	36	Name	Control Function	Type	0	1	Default
Bit 7		N Div10	N Divider Programming Byte20 bit(7:0) and Byte19 bit(7:6)	RW	The decimal representation of M and N Divider in Byte 26 and 36 will configure the VCO frequency. Default at power up = Byte 5 Rom table. See MN Calculation Tables for VCO frequency formulas.		X
Bit 6		N Div9		RW			X
Bit 5		N Div8		RW			X
Bit 4		N Div7		RW			X
Bit 3		N Div6		RW			X
Bit 2		N Div5		RW			X
Bit 1		N Div4		RW			X
Bit 0		N Div3		RW			X

SMBUS Table: ATIG PLL DOC 3 N programming Register (1 pin control : DOC = 1; 2 pin control : DOC [0:1] = 11)

Byte	37	Name	Control Function	Type	0	1	Default
Bit 7		N Div10	N Divider Programming Byte20 bit(7:0) and Byte19 bit(7:6)	RW	The decimal representation of M and N Divider in Byte 26 and 37 will configure the VCO frequency. Default at power up = Byte 5 Rom table. See MN Calculation Tables for VCO frequency formulas.		X
Bit 6		N Div9		RW			X
Bit 5		N Div8		RW			X
Bit 4		N Div7		RW			X
Bit 3		N Div6		RW			X
Bit 2		N Div5		RW			X
Bit 1		N Div4		RW			X
Bit 0		N Div3		RW			X

SMBUS Table: SRC PLL DOC 1 N programming Register (1 pin control : DOC = 1; 2 pin control : DOC [0:1] = 01)

Byte	38	Name	Control Function	Type	0	1	Default
Bit 7		N Div10	N Divider Programming Byte20 bit(7:0) and Byte19 bit(7:6)	RW	The decimal representation of M and N Divider in Byte 21 and 38 will configure the VCO frequency. Default at power up = Byte 4 Rom table. See MN Calculation Tables for VCO frequency formulas.		X
Bit 6		N Div9		RW			X
Bit 5		N Div8		RW			X
Bit 4		N Div7		RW			X
Bit 3		N Div6		RW			X
Bit 2		N Div5		RW			X
Bit 1		N Div4		RW			X
Bit 0		N Div3		RW			X

SMBUS Table: SRC PLL DOC 2 N programming Register (1 pin control : DOC = 1; 2 pin control : DOC [0:1] = 10)

Byte	39	Name	Control Function	Type	0	1	Default
Bit 7		N Div10	N Divider Programming Byte20 bit(7:0) and Byte19 bit(7:6)	RW	The decimal representation of M and N Divider in Byte 21 and 39 will configure the VCO frequency. Default at power up = Byte 4 Rom table. See MN Calculation Tables for VCO frequency formulas.		X
Bit 6		N Div9		RW			X
Bit 5		N Div8		RW			X
Bit 4		N Div7		RW			X
Bit 3		N Div6		RW			X
Bit 2		N Div5		RW			X
Bit 1		N Div4		RW			X
Bit 0		N Div3		RW			X

SMBUS Table: SRC PLL DOC 3 N programming Register (1 pin control : DOC = 1; 2 pin control : DOC [0:1] = 11)

Byte	40	Name	Control Function	Type	0	1	Default
Bit 7		N Div10	N Divider Programming Byte20 bit(7:0) and Byte19 bit(7:6)	RW	The decimal representation of M and N Divider in Byte 21 and 37 will configure the VCO frequency. Default at power up = Byte 4 Rom table. See M/N Calculation Tables for VCO frequency formulas.		X
Bit 6		N Div9		RW			X
Bit 5		N Div8		RW			X
Bit 4		N Div7		RW			X
Bit 3		N Div6		RW			X
Bit 2		N Div5		RW			X
Bit 1		N Div4		RW			X
Bit 0		N Div3		RW			X

SMBus Table: ATIG PLL Spread Spectrum Control Register

Byte	41	Name	Control Function	Type	0	1	Default
Bit 7		SSP7	Spread Spectrum Programming b(7:0)	RW	These bits set the ATIG spread percentage. Please contact IDT for the appropriate values.		X
Bit 6		SSP6		RW			X
Bit 5		SSP5		RW			X
Bit 4		SSP4		RW			X
Bit 3		SSP3		RW			X
Bit 2		SSP2		RW			X
Bit 1		SSP1		RW			X
Bit 0		SSP0		RW			X

SMBus Table: ATIG PLL Spread Spectrum Control Register

Byte	42	Name	Control Function	Type	0	1	Default
Bit 7		SSP15	Spread Spectrum Programming b(15:8)	RW	These bits set the ATIG spread percentage. Please contact IDT for the appropriate values.		X
Bit 6		SSP14		RW			X
Bit 5		SSP13		RW			X
Bit 4		SSP12		RW			X
Bit 3		SSP11		RW			X
Bit 2		SSP10		RW			X
Bit 1		SSP9		RW			X
Bit 0		SSP8		RW			X

Absolute Maximum Rating

PARAMETER	SYMBOL	CONDITIONS	MIN	TYP	MAX	UNITS	Notes
3.3V Core Supply Voltage	VDDxxx	-		3.3	GND + 3.9V	V	1
Storage Temperature	Ts	-	-65		150	°C	1
Ambient Operating Temp	Tambient	-	0		70	°C	1
Case Temperature	Tcase	-			115	°C	1
Input ESD protection HBM	ESD prot	-	2000			V	1

¹Guaranteed by design and characterization, not 100% tested in production.

Electrical Characteristics - Input/Supply/Common Output Parameters

PARAMETER	SYMBOL	CONDITIONS*	MIN	TYP	MAX	UNITS	Notes
3.3V Core Supply Voltage	VDDxxx	-	3.135	3.3	3.465	V	1
Input High Voltage	V _{IH}	VDD = 3.3 V +/-5%	2		V _{DD} + 0.3	V	1
Input Low Voltage	V _{IL}	VDD = 3.3 V +/-5%	V _{SS} - 0.3		0.8	V	1
Input High Current	I _{IH}	V _{IN} = V _{DD}	-5		5	uA	1
Input Low Current	I _{IL1}	V _{IN} = 0 V; Inputs with no pull-up resistors	-5			uA	1
	I _{IL2}	V _{IN} = 0 V; Inputs with pull-up resistors	-200			uA	1
Low Threshold Input-High Voltage	V _{IH_FS}	VDD = 3.3 V +/-5%	0.7		V _{DD} + 0.3	V	1
Low Threshold Input-Low Voltage	V _{IL_FS}	VDD = 3.3 V +/-5%	V _{SS} - 0.3		0.35	V	1
Operating Current	I _{DD3.3OP}	all outputs driven			225	mA	1
Powerdown Current	I _{DD3.3PD}	all diff pairs low /low			12	mA	1
Input Frequency	F _i	VDD = 3.3 V +/-5%		14.31818		MHz	2
Pin Inductance	L _{pin}				7	nH	1
Input Capacitance	C _{IN}	Logic Inputs			5	pF	1
	C _{OUT}	Output pin capacitance			6	pF	1
	C _{INX}	X1 & X2 pins			5	pF	1
Clk Stabilization	T _{STAB}	From VDD Power-Up or de-assertion of PD to 1st clock			1.8	ms	1
Modulation Frequency		Triangular Modulation	30		33	kHz	1
Tdrive_PD		CPU output enable after PD de-assertion			300	us	1
Tfall_PD		PD fall time of			5	ns	1
Trise_PD		PD rise time of			5	ns	1
SMBus Voltage	V _{DDSMB}		2.7		5.5	V	1
Low-level Output Voltage	V _{OLSMB}	@ I _{PULLUP}			0.4	V	1
Current sinking at V _{OL} = 0.4 V	I _{PULLUPSMB}		4	6		mA	1
SMBCLK/SMBDAT Clock/Data Rise Time	T _{RSMB}	(Max VIL - 0.15) to (Min VIH + 0.15)			1000	ns	1
SMBCLK/SMBDAT Clock/Data Fall Time	T _{FSMB}	(Min VIH + 0.15) to (Max VIL - 0.15)			300	ns	1

*TA = 0 - 70°C; Supply Voltage VDD = 3.3 V +/-5%

¹Guaranteed by design and characterization, not 100% tested in production.

² Input frequency should be measured at the REF pin and tuned to ideal 14.31818MHz to meet ppm frequency accuracy on PLL outputs.

AC Electrical Characteristics - Low-Power DIF Outputs: CPUKG and HTT

PARAMETER	SYMBOL	CONDITIONS	MIN	TYP	MAX	UNITS	NOTES
Crossing Point Variation	ΔV_{CROSS}	Single-ended Measurement			140	mV	1,2,5
Frequency	f	Spread Specturm On	198.8		200	MHz	1,3
Long Term Accuracy	ppm	Spread Specturm Off	-300		+300	ppm	1,11
Rising Edge Slew Rate	S_{RISE}	Differential Measurement	0.5		10	V/ns	1,4
Falling Edge Slew Rate	S_{FALL}	Differential Measurement	0.5		10	V/ns	1,4
Slew Rate Variation	t_{SLVAR}	Single-ended Measurement			20	%	1
CPU, DIF HTT Jitter - Cycle to Cycle	CPU_{C2C}	Differential Measurement			150	ps	1,6
Accumulated Jitter	t_{JACC}	See Notes			1	ns	1,7
Peak to Peak Differential Voltage	$V_{\text{D(PK-PK)}}$	Differential Measurement	400		2400	mV	1,8
Differential Voltage	V_{D}	Differential Measurement	200		1200	mV	1,9
Duty Cycle	D_{CYC}	Differential Measurement	45		55	%	1
Amplitude Variation	ΔV_{D}	Change in V_{D} DC cycle to cycle	-75		75	mV	1,10
CPU[1:0] Skew	$\text{CPU}_{\text{SKEW10}}$	Differential Measurement			100	ps	1

*TA = 0 - 70°C; Supply Voltage VDD = 3.3 V +/-5%, CL = 2pF with Rs = 0Ω (unless otherwise specified)

¹Guaranteed by design and characterization, not 100% tested in production.

²Single-ended measurement at crossing point. Value is maximum – minimum over all time. DC value of common mode is not important due to the blocking cap.

³Minimum Frequency is a result of 0.5% down spread spectrum

⁴Differential measurement through the range of ±100 mV, differential signal must remain monotonic and within slew rate spec when crossing through this region.

⁵ Defined as the total variation of all crossing voltages of CLK rising and CLK# falling. Matching applies to rising edge rate of CLK and falling edge of CLK#. It is measured using a +/-75mV window centered on the average cross point where CLK meets CLK#.

⁶ Max difference of t_{CYCLE} between any two adjacent cycles.

⁷ Accumulated tjc over a 10μs time period, measured with JIT2 TIE at 50ps interval.

⁸ VD(PK-PK) is the overall magnitude of the differential signal.

⁹ VD(min) is the amplitude of the ring-back differential measurement, guaranteed by design, that ring-back will not cross 0V VD. VD(max) is the largest amplitude allowed.

¹⁰ The difference in magnitude of two adjacent VD_DC measurements. VD_DC is the stable post overshoot and ring-back part of the signal.

¹¹ All Long Term Accuracy and Clock Period specifications are guaranteed assuming that REFOUT is at 14.31818MHz

AC Electrical Characteristics - Low-Power DIF Outputs: SRC, SB_SRC, ATIG

PARAMETER	SYMBOL	CONDITIONS	MIN	TYP	MAX	UNITS	NOTES
Rising Edge Slew Rate	t_{SLR}	Differential Measurement	0.6		4	V/ns	1,2
Falling Edge Slew Rate	t_{FLR}	Differential Measurement	0.6		4	V/ns	1,2
Slew Rate Variation	t_{SLVAR}	Single-ended Measurement			20	%	1
Maximum Output Voltage	V_{HIGH}	Includes overshoot			1150	mV	1
Minimum Output Voltage	V_{LOW}	Includes undershoot	-300			mV	1
Differential Voltage Swing	V_{SWING}	Differential Measurement	300			mV	1
Crossing Point Voltage	V_{XABS}	Single-ended Measurement	300		550	mV	1,3,4
Crossing Point Variation	$V_{XABSVAR}$	Single-ended Measurement			140	mV	1,3,5
Duty Cycle	D_{CYC}	Differential Measurement	45		55	%	1
SRC, SB_SRC, ATIG, Jitter - Cycle to Cycle	$SRCJ_{C2C}$	Differential Measurement			125	ps	1
SRC[5:0] Skew	SRC_{SKEW}	Differential Measurement			250	ps	1
SB_SRC[1:0] Skew	SRC_{SKEW}	Differential Measurement			100	ps	1
ATIG[3:0] Skew	SRC_{SKEW}	Differential Measurement			100	ps	1

*TA = 0 - 70°C; Supply Voltage VDD = 3.3 V +/-5%, CL = 2pF with Rs = 0Ω (unless otherwise specified)

¹Guaranteed by design and characterization, not 100% tested in production.

²Slew rate measured through Vswing centered around differential zero

³Vxabs is defined as the voltage where CLK = CLK#

⁴Only applies to the differential rising edge (CLK rising and CLK# falling)

⁵Defined as the total variation of all crossing voltages of CLK rising and CLK# falling. Matching applies to rising edge rate of CLK and falling edge of CLK#. It is measured using a +/-75mV window centered on the average cross point where CLK meets CLK#.

⁶All Long Term Accuracy and Clock Period specifications are guaranteed assuming that REFOUT is at 14.31818MHz

Electrical Characteristics - Single-Ended HTT 66MHz Clock

PARAMETER	SYMBOL	CONDITIONS	MIN	TYP	MAX	UNITS	Notes
Long Accuracy	ppm	see Tperiod min-max values	-300		300	ppm	1,2
PCI33 Clock period	T_{period}	33.33MHz output nominal	29.9910		30.0090	ns	2
		33.33MHz output spread	29.9910		30.1598	ns	2
HTT66 Clock period	T_{period}	66.67MHz output nominal	14.9955		15.0045	ns	2
		66.67MHz output spread	14.9955		15.0799	ns	2
Output High Voltage	V_{OH}	$I_{OH} = -1 \text{ mA}$	2.4			V	1
Output Low Voltage	V_{OL}	$I_{OL} = 1 \text{ mA}$			0.55	V	1
Output High Current	I_{OH}	$V_{OH} @ \text{MIN} = 1.0 \text{ V}$	-33			mA	1
		$V_{OH} @ \text{MAX} = 3.135 \text{ V}$			-33	mA	1
Output Low Current	I_{OL}	$V_{OL} @ \text{MIN} = 1.95 \text{ V}$	30			mA	1
		$V_{OL} @ \text{MAX} = 0.4 \text{ V}$			38	mA	1
Edge Rate	$2\sqrt{2} t$	Rising edge rate	1		4	V/ns	1
Edge Rate	$2\sqrt{2} t$	Falling edge rate	1		4	V/ns	1
Rise Time	t_{r1}	$V_{OL} = 0.4 \text{ V}, V_{OH} = 2.4 \text{ V}$	0.5		2	ns	1
Fall Time	t_{f1}	$V_{OH} = 2.4 \text{ V}, V_{OL} = 0.4 \text{ V}$	0.5		2	ns	1
Duty Cycle	d_{t1}	$V_T = 1.5 \text{ V}$	45		55	%	1
Jitter, Cycle to cycle	$t_{jvc-cyc}$	$V_T = 1.5 \text{ V}$			180	ps	1

*TA = 0 - 70°C; Supply Voltage VDD = 3.3 V +/-5%, CL = 5pF with Rs = 33Ω (unless otherwise specified)

¹Guaranteed by design and characterization, not 100% tested in production.

²All Long Term Accuracy and Clock Period specifications are guaranteed with the assumption that REF is at 14.31818MHz

Electrical Characteristics - USB - 48MHz

PARAMETER	SYMBOL	CONDITIONS*	MIN	TYP	MAX	UNITS	NOTES
Long Accuracy	ppm	see Tperiod min-max values	-100		100	ppm	1,2
Clock period	T _{period}	48.00MHz output nominal	20.8229		20.8344	ns	2
Clock Low Time	T _{low}	Measure from < 0.6V	9.3750		11.4580	ns	2
Clock High Time	T _{high}	Measure from > 2.0V	9.3750		11.4580	ns	2
Output High Voltage	V _{OH}	I _{OH} = -1 mA	2.4			V	1
Output Low Voltage	V _{OL}	I _{OL} = 1 mA			0.55	V	1
Output High Current	I _{OH}	V _{OH} @MIN = 1.0 V	-33			mA	1
		V _{OH} @MAX = 3.135 V			-33	mA	1
Output Low Current	I _{OL}	V _{OL} @ MIN = 1.95 V	30			mA	1
		V _{OL} @ MAX = 0.4 V			38	mA	1
Rise Time	t _{r USB}	V _{OL} = 0.4 V, V _{OH} = 2.4 V	0.5		1.5	ns	1
Fall Time	t _{f USB}	V _{OH} = 2.4 V, V _{OL} = 0.4 V	0.5		1.5	ns	1
Duty Cycle	d _{t1}	V _T = 1.5 V	45		55	%	1
Group Skew	t _{skew}	V _T = 1.5 V			250	ps	1
Jitter, Cycle to cycle	t _{cyc-cyc}	V _T = 1.5 V			130	ps	1,2

*TA = 0 - 70°C; Supply Voltage VDD = 3.3 V +/-5%, CL = 5pF with Rs = 33Ω (unless otherwise specified)

¹Guaranteed by design and characterization, not 100% tested in production.

²ICS recommended and/or chipset vendor layout guidelines must be followed to meet this specification

Electrical Characteristics - REF-14.318MHz

PARAMETER	SYMBOL	CONDITIONS	MIN	TYP	MAX	UNITS	Notes
Long Accuracy	ppm	see Tperiod min-max values	-300		300	ppm	1,2
Clock period	T _{period}	14.318MHz output nominal	69.8270		69.8550	ns	2
Clock Low Time	T _{low}	Measure from < 0.6V	30.9290		37.9130	ns	2
Clock High Time	T _{high}	Measure from > 2.0V	30.9290		37.9130	ns	2
Output High Voltage	V _{OH}	I _{OH} = -1 mA	2.4			V	1
Output Low Voltage	V _{OL}	I _{OL} = 1 mA			0.4	V	1
Output High Current	I _{OH}	V _{OH} @MIN = 1.0 V,	-29			mA	1
		V _{OH} @MAX = 3.135 V			-23	mA	1
Output Low Current	I _{OL}	V _{OL} @MIN = 1.95 V,	29			mA	1
		V _{OL} @MAX = 0.4 V			27	mA	1
Rise Time	t _{r1}	V _{OL} = 0.4 V, V _{OH} = 2.4 V	1		1.5	ns	1
Fall Time	t _{f1}	V _{OH} = 2.4 V, V _{OL} = 0.4 V	1		1.5	ns	1
Skew	t _{sk1}	V _T = 1.5 V			250	ps	1
Duty Cycle	d _{t1}	V _T = 1.5 V	45		55	%	1
Jitter	t _{cyc-cyc}	V _T = 1.5 V			200	ps	1

*TA = 0 - 70°C; Supply Voltage VDD = 3.3 V +/-5%, CL = 5pF with Rs = 33Ω (unless otherwise specified)

¹Guaranteed by design and characterization, not 100% tested in production.

²All Long Term Accuracy and Clock Period specifications are guaranteed assuming that REFOUT is at 14.31818MHz

Clock Jitter Specifications - Low Power Differential Outputs

PARAMETER	SYMBOL	CONDITIONS	MIN	TYP	MAX	UNITS	NOTES
SRC/SB_SRC/ATIG Phase Jitter	$t_{j\text{phasePLL}}$	PCIe Gen 1			86	ps (p-p)	1,2
	$t_{j\text{phaseLo}}$	PCIe Gen 2 10kHz < f < 1.5MHz			3	ps (RMS)	1,4
	$t_{j\text{phaseHigh}}$	PCIe Gen 2 1.5MHz < f < Nyquist (50MHz)			3.1	ps (RMS)	1,4

*TA = 0 - 70°C; Supply Voltage VDD = 3.3V +/-5%, Rs = 0ohms, CL = 2pF

¹ Unless otherwise noted, guaranteed by design and characterization, not 100% tested in production.

² Jitter specs are specified as measured on a clock characterization board. System designers need to take special care not to use these numbers, as the in-system performance will be somewhat degraded. The receiver EMTS (chispet or CPU) will have the receiver

³ Phase jitter requirement: The designated Gen2 outputs will meet the reference clock jitter requirements from the PCI Express Gen2 Base Spec. The test is performed on a component test board under quiet conditions with all outputs on.

⁴ See <http://www.pcisig.com> for complete specs

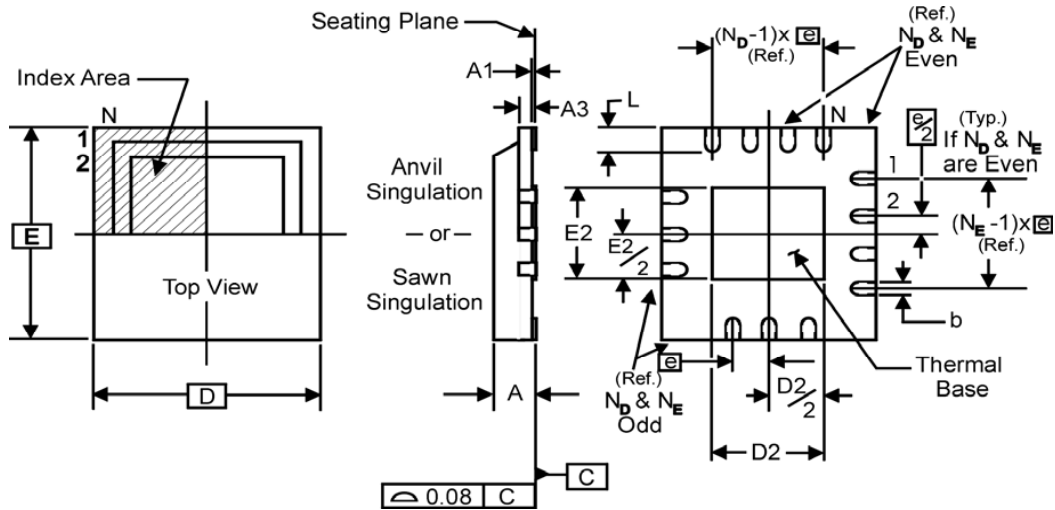

**THERMALLY ENHANCED, VERY THIN, FINE PITCH
 QUAD FLAT / NO LEAD PLASTIC PACKAGE**

DIMENSIONS

SYMBOL	64L
N	64
N _D	16
N _E	16

OPTION 1 DIMENSIONS (mm)

SYMBOL	MIN.	MAX.
A	0.8	1.0
A1	0	0.05
A3	0.25 Reference	
b	0.18	0.3
e	0.50 BASIC	
D x E BASIC	9.00 x 9.00	
D2 MIN. / MAX.	7.00	7.25
E2 MIN. / MAX.	7.00	7.25
L MIN. / MAX.	0.30	0.50

OPTION 2 DIMENSIONS (mm)

SYMBOL	MIN.	MAX.
A	0.8	1.0
A1	0	0.05
A3	0.25 Reference	
b	0.18	0.3
e	0.50 BASIC	
D x E BASIC	9.00 x 9.00	
D2 MIN. / MAX.	6.00	6.25
E2 MIN. / MAX.	6.00	6.25
L MIN. / MAX.	0.30	0.50

Ordering Information

9LPRS477CKLFT

*Due to package size constraints actual top side marking may differ from the full orderable part number.

Example:

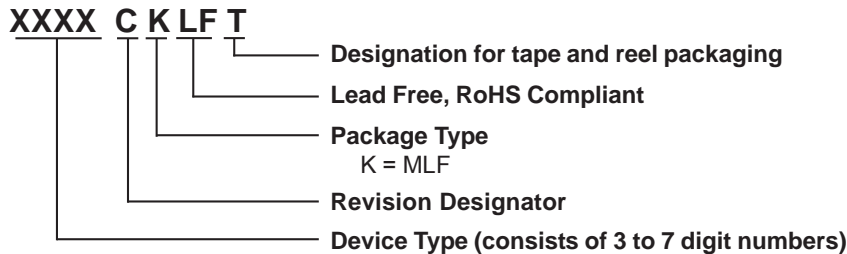

Revision History

Rev.	Issue Date	Description	Page #
0.1	10/2/2007	Initial Release	-
0.2	3/20/2008	Added IO_Vout select table	7
0.3	4/8/2008	1. Updated MLF Ordering Information. 2. Reformatted Dimensions Tables	20
0.4		Fixed typo in Electrical Specifications	
0.5	9/16/2009	Updated Power Group Table.	4
0.6	2/5/2010	Updated electrical tables; updated document template	Various
0.7	2/19/2010	Corrected RESTORE# pin description	3
0.8	5/23/2012	Added marking diagram/notes.	20
A	1/28/2014	Moved to final per characterization data.	-

IMPORTANT NOTICE AND DISCLAIMER

RENESAS ELECTRONICS CORPORATION AND ITS SUBSIDIARIES (“RENESAS”) PROVIDES TECHNICAL SPECIFICATIONS AND RELIABILITY DATA (INCLUDING DATASHEETS), DESIGN RESOURCES (INCLUDING REFERENCE DESIGNS), APPLICATION OR OTHER DESIGN ADVICE, WEB TOOLS, SAFETY INFORMATION, AND OTHER RESOURCES “AS IS” AND WITH ALL FAULTS, AND DISCLAIMS ALL WARRANTIES, EXPRESS OR IMPLIED, INCLUDING, WITHOUT LIMITATION, ANY IMPLIED WARRANTIES OF MERCHANTABILITY, FITNESS FOR A PARTICULAR PURPOSE, OR NON-INFRINGEMENT OF THIRD PARTY INTELLECTUAL PROPERTY RIGHTS.

These resources are intended for developers skilled in the art designing with Renesas products. You are solely responsible for (1) selecting the appropriate products for your application, (2) designing, validating, and testing your application, and (3) ensuring your application meets applicable standards, and any other safety, security, or other requirements. These resources are subject to change without notice. Renesas grants you permission to use these resources only for development of an application that uses Renesas products. Other reproduction or use of these resources is strictly prohibited. No license is granted to any other Renesas intellectual property or to any third party intellectual property. Renesas disclaims responsibility for, and you will fully indemnify Renesas and its representatives against, any claims, damages, costs, losses, or liabilities arising out of your use of these resources. Renesas' products are provided only subject to Renesas' Terms and Conditions of Sale or other applicable terms agreed to in writing. No use of any Renesas resources expands or otherwise alters any applicable warranties or warranty disclaimers for these products.

(Rev.1.0 Mar 2020)

Corporate Headquarters

TOYOSU FORESIA, 3-2-24 Toyosu,
Koto-ku, Tokyo 135-0061, Japan
www.renesas.com

Contact Information

For further information on a product, technology, the most up-to-date version of a document, or your nearest sales office, please visit:
www.renesas.com/contact/

Trademarks

Renesas and the Renesas logo are trademarks of Renesas Electronics Corporation. All trademarks and registered trademarks are the property of their respective owners.