

MODEL RS - DIN RAIL RELAY SYSTEM

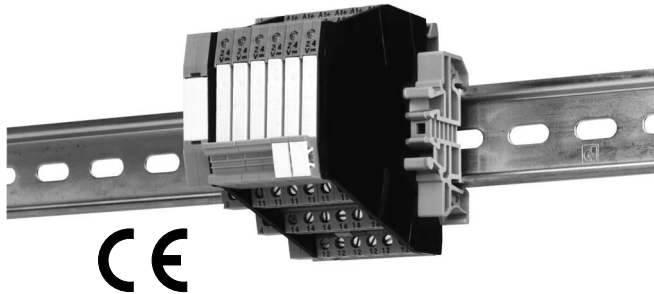

- TERMINAL BLOCKS WITH BUILT-IN RELAY OUTPUTS
- SLIM DESIGN SAVES DIN RAIL SPACE
- REPLACEABLE RELAY SAVES DOWNTIME
- JUMPERS SAVE WIRING TIME



UL Recognized Component,
 File # E137808

DESCRIPTION

The RS Relay System provides a compact, modular means of adding relay outputs to any transistor output device. The RSRLYB Relay Block serves as the base for a miniature, 24 volt coil relay, capable of switching up to 250 VAC at 6 Amps. Accessories, such as Jumpers, Buss Blocks, and Relay Markers are available to save installation time and money.

RELAY BLOCK-RSRLYB

The RS Relay System is built around the Relay Block. The Relay Block is a 6.2 mm wide terminal block that serves as the base for the miniature plug-in relay (included). The relay has a 24 VDC coil, and its SPDT output can switch loads up to 250 VAC at 6 Amps. With its plug-in design, the relay can be replaced in seconds. The Block has a built-in suppression circuit to reduce EMC interference. Other features include an input LED, and reverse polarity protection. The RSRLYB00 is shipped in packages of 5 pieces, with the relay installed.

13. **MIN. SWITCHING POWER:** 120 mW
14. **INPUT TO OUTPUT ISOLATION:** 4 kV, 50 Hz., 1 minute
15. **AMBIENT TEMPERATURE RANGE:** -20 to 60°C (-4 to 140°F)
16. **NOMINAL OPERATING MODE:** 100% Duty Cycle
17. **INFLAMMABILITY CLASS:** VO according To UL 94
18. **MECHANICAL LIFE:** 20 million cycles
19. **CONSTRUCTION:** Case body is green, Polyimide PA non-reinforced
20. **CONNECTIONS:** 14 AWG max. Torque 4-6 in-lb.
21. **MOUNTING:** Standard DIN Top Hat (T) profile rail according to EN50022 -35 x 7.5 and 35 x 15.
22. **WEIGHT:** 0.073 lb. (33.1 g)

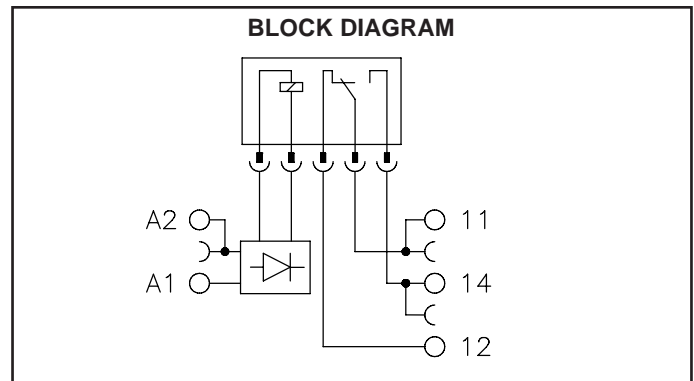
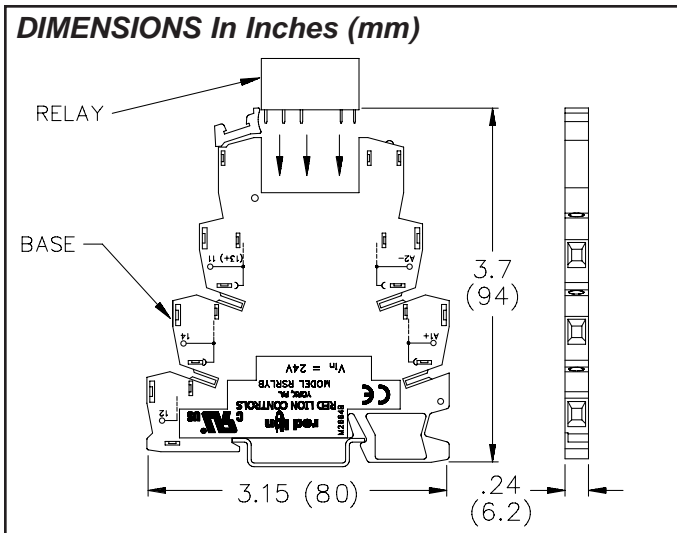

SPECIFICATIONS

1. **NOMINAL INPUT VOLTAGE:** 24 VDC
2. **TYPICAL INPUT CURRENT @ 24 VDC:** 9 mA
3. **TYPICAL OPERATE TIME:** 4 msec
4. **TYPICAL RELEASE TIME:** 8 msec
5. **CONTACT TYPE:** SPDT (Form C)
6. **CONTACT MATERIAL:** AgSnO
7. **MAX. CONTACT VOLTAGE:** 250 V AC/DC
8. **MIN. CONTACT VOLTAGE:** 12 V AC/DC
9. **LIMITING CONTINUOUS CURRENT:** 6 A
10. **MAX. INRUSH CURRENT:** 30 A
11. **MIN. SWITCHING CURRENT:** 10 mA
12. **MAX. POWER RATING (RESISTIVE LOAD):** 140 W

2-POSITION JUMPER-RSJMPR

The RSJMPR Jumper can be used to bridge connections between adjacent Relay Blocks. This avoids the tedious task of wire-jumping signals such as commons or neutrals together. The maximum current capability of the RSJMPR is 6 A. The RSJMPR is available in three different colors, and is shipped in packages of 20 pieces.

SPECIFICATIONS

1. **MAX. CURRENT:** 6 A
2. **LENGTH:** 0.24" (6 mm)
3. **COLOR:** Available in Red, Blue, and Gray

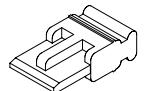

CONTINUOUS JUMPER-RSCJMP

The RSCJMP can be used to bridge up to 80 adjacent Relay Blocks with total currents as high as 30 A. For currents above 6 A, the Buss Block must be used as the starting point. This cut-to-length jumper is available in three colors, and is shipped in packages of 2 pieces.

SPECIFICATIONS

1. **MAX. CURRENT:** 30 A
2. **LENGTH:** 19.7" (500 mm)
3. **COLOR:** Available in Red, Blue, and Gray

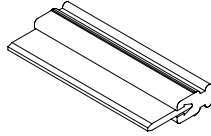

BUSS BLOCK-RSBUSS

The 9 mm wide Buss Block is the same shape as the RSRLYB Relay Block. It can be used as a starting point for the continuous jumper in applications requiring up to 30 A. In applications that require less than 6 A, the starting point for the jumper(s) can take place at one of the Relay Blocks.

SPECIFICATIONS

1. **MAX. CURRENT:** 30 A
2. **MAX. VOLTAGE:** 250 V
3. **CONSTRUCTION:** Case body is gray, Polymide PA non-reinforced
4. **CONNECTIONS:** 10 AWG max. Torque 4-6 in-lb.
5. **WEIGHT:** 0.077 lb. (34.9 g)

BARRIER-RSBARR

The Barrier is always required at the start and end of a Relay System to provide protective separation according to VDC 0106-101. The Barrier should also be used to isolate adjacent Relay Blocks with voltage potentials greater than 250 V. The RSBARR is equipped with prescored breakout points at the bridging positions so that individual bridges can pass through if needed. The RSBARR00 is shipped in packages of 2 pieces.

SPECIFICATIONS

1. **COLOR:** Black

RELAY MARKERS-RSMARK

The RSMARK00 Relay Markers can be used to label the Relay Blocks. After labeling or writing on the Marker, it is snapped onto the engagement lever of the Relay Block, providing a visual means of identification. The RSMARK00 is shipped in packages of 100 pieces.

SPECIFICATIONS

1. **COLOR:** White

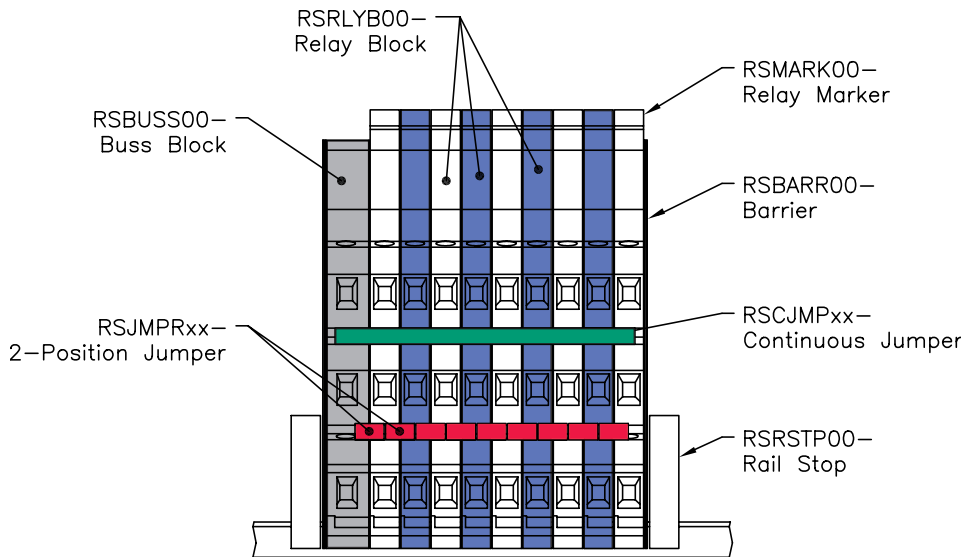

ORDERING INFORMATION

MODEL NO.	DESCRIPTION	QUANTITY/PACKAGE	PART NUMBER
RSRLYB	Relay Block	5	RSRLYB00
RSBUSS	Buss Block	1	RSBUSS00
RSBARR	Barrier	2	RSBARR00
RSRSTP	Rail Stop	2	RSRSTP00
RSJMPR	2-Position Jumper Red	20	RSJMPR10
	2-Position Jumper Blue	20	RSJMPR20
	2-Position Jumper Gray	20	RSJMPR30
RSCJMP	Continuous Jumper Red	2	RSCJMP10
	Continuous Jumper Blue	2	RSCJMP20
	Continuous Jumper Gray	2	RSCJMP30
RSMARK	Relay Marker	100	RSMARK00
RSRLY1	Replacement Relay	5	RSRLY100