

# Screw plug - A-INSP-PG21-65N-P-LG - 1424524

Please be informed that the data shown in this PDF Document is generated from our Online Catalog. Please find the complete data in the user's documentation. Our General Terms of Use for Downloads are valid (<http://phoenixcontact.com/download>)

Screw plug, material: PA, connecting thread: Pg21, color: lightgrey RAL 7035



## Key Commercial Data

Packing unit	10 pc
Minimum order quantity	10 pc
GTIN	 4 055626 374291
GTIN	4055626374291

## Technical data

### Dimensions

Length	11 mm
Length without connecting thread	3 mm
Connecting thread diameter	28.3 mm
Hexagon angular dimension	33 mm (Diameter)
Length of the connecting thread	8 mm

### Ambient conditions

Degree of protection (IP)	IP65
Ambient temperature (operation)	-40 °C ... 100 °C

### General

Material	PA
Sealing material	EPDM (O-ring)
Color	lightgrey RAL 7035

### Environmental Product Compliance

China RoHS	Environmentally friendly use period: unlimited = EFUP-e
	No hazardous substances above threshold values

# Screw plug - A-INSP-PG21-65N-P-LG - 1424524

## Drawings

Dimensional drawing

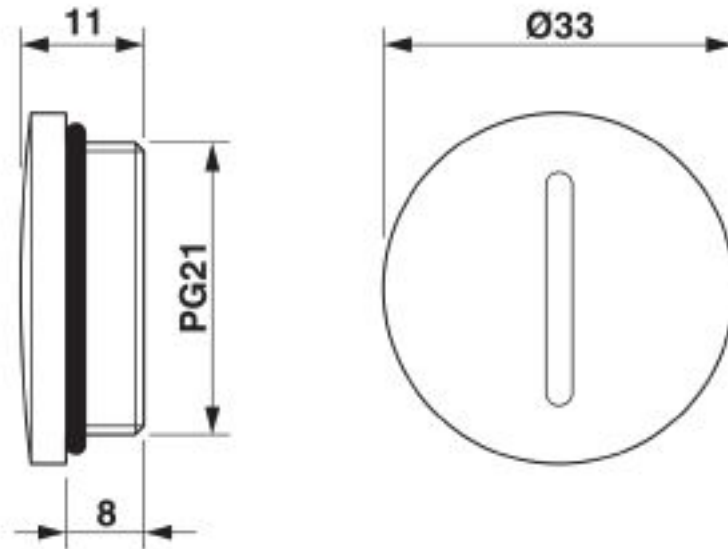

Dimensional drawing

## Classifications

### eCl@ss

eCl@ss 10.0.1	23111190
eCl@ss 4.0	23111100
eCl@ss 4.1	23111100
eCl@ss 5.0	23111100
eCl@ss 5.1	23111100
eCl@ss 6.0	23111100
eCl@ss 7.0	23111190
eCl@ss 8.0	23111190
eCl@ss 9.0	23111190

### ETIM

ETIM 5.0	EC000032
ETIM 6.0	EC000032
ETIM 7.0	EC000032

## Approvals

### Approvals

## Screw plug - A-INSP-PG21-65N-P-LG - 1424524

### Approvals

Approvals

EAC

---

Ex Approvals

---

### Approval details

EAC		EAC-Zulassung
-----	---	---------------

### Accessories

Accessories

Flat nut

Counter nut - A-INL-PG21-P-LG - 1424553



Counter nut, material: PA 6 GF 30, connecting thread: Pg21, color: lightgrey RAL 7035

---

Phoenix Contact 2020 © - all rights reserved  
<http://www.phoenixcontact.com>

PHOENIX CONTACT GmbH & Co. KG  
Flachsmarktstr. 8  
32825 Blomberg  
Germany  
Tel. +49 5235 300  
Fax +49 5235 3 41200  
<http://www.phoenixcontact.com>