

**Features and Benefits**

- Magnetic technology offers robust performance.
- 100% Non-contacting design (no bearings or bushing) provides an extremely long life expectancy and is tolerant to harsh environments.
- Simple two piece design (target magnet + encoder) for easy alignment and installation.
- Bi-directional two channel incremental quadrature output.
- Mounting holes for a 2-bolt pattern 1.280 inch B.C. x 0.125 inch O.D.
- Target magnet for standard shaft sizes from 2 mm to 1/2 inch. Custom bore size available.
- Options up to 30 pulse per channel per revolution.
- Customizable lead wires, cables, and or connectors.

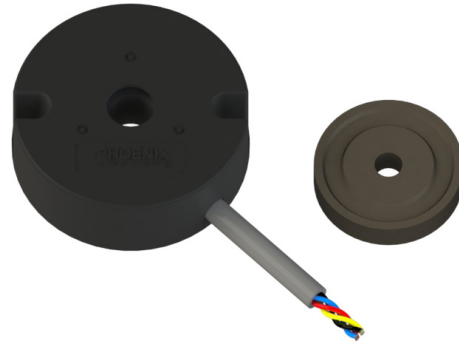

Kit - Encoder with Target Magnet  
*Shown with shaft pass through hole*  
*Wire color order varies with part configuration*

**Application Example**

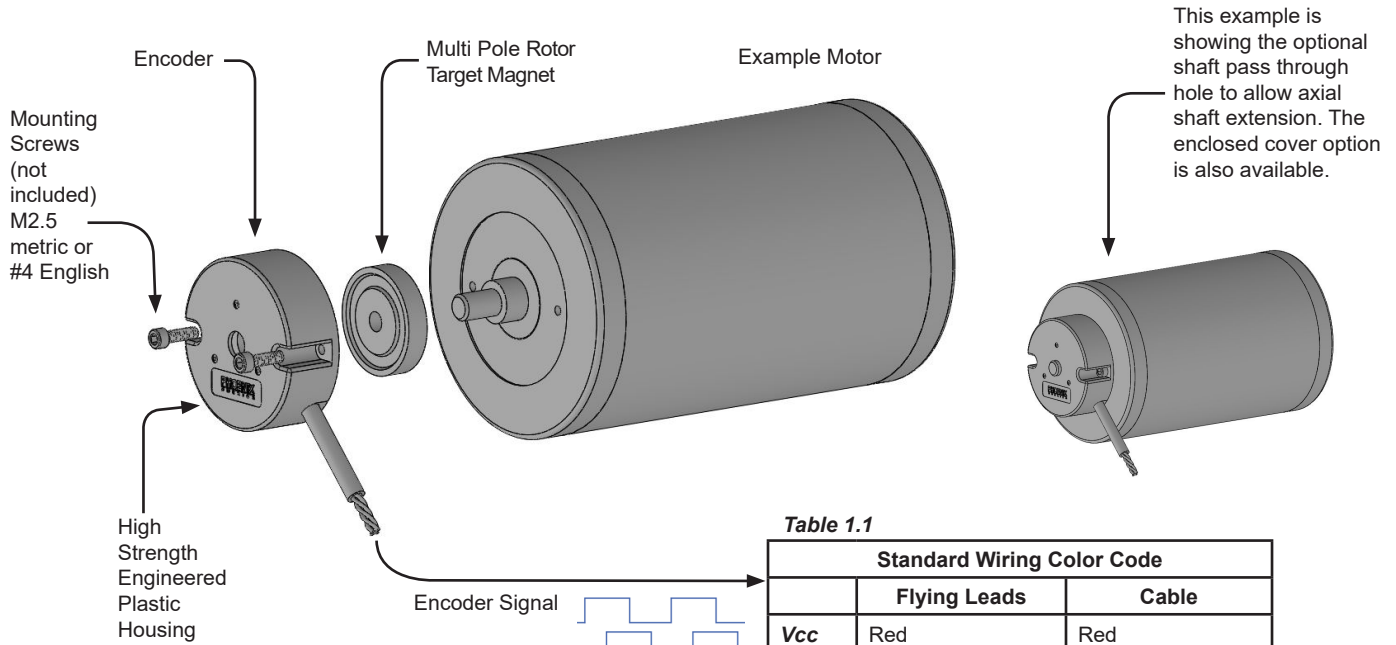
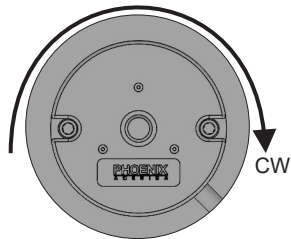
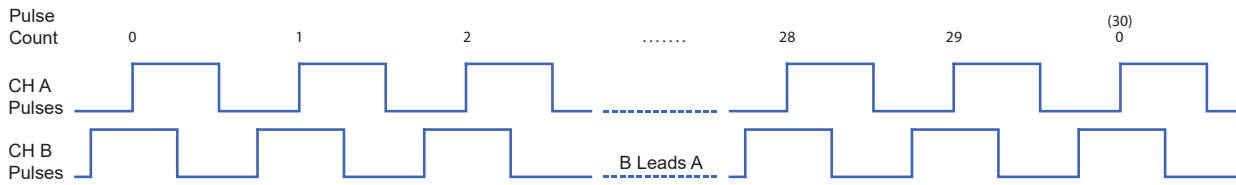
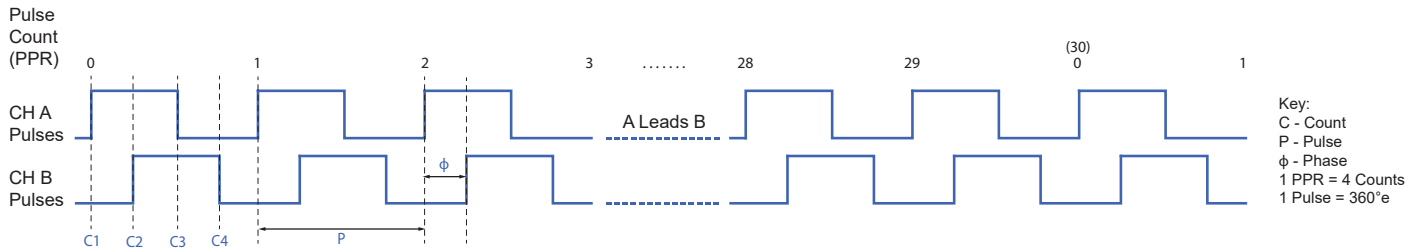

**Table 1.1**

Standard Wiring Color Code		
	Flying Leads	Cable
<b>Vcc</b>	Red	Red
<b>Gnd</b>	Black	Black
<b>Ch A</b>	Yellow	Brown
<b>Ch B</b>	Blue	Orange

*Other colors available upon request.*  
*Contact sales@phoenixamerica.com.*

**Output Waveforms**



Channel A leads Channel B for clockwise shaft rotation (shaft rotation is defined when looking at the branded face of the encoder).

**Absolute Maximum Ratings**

Table 2.1

Characteristic	Symbol	Rating	Units
Forward Supply Voltage	$V_{CC}$	32	V
Reverse Supply Voltage	$V_{RCC}$	-0.3	V
Output Voltage	$V_{OUT}$	32	V
Continuous Output Current	$I_{OUT}$	20	mA
Operating Temperature	$T_A$	-40 - 125	°C
Storage Temperature	$T_S$	-40 - 150	°C

**Electrical Characteristics**

Table 2.2

Characteristic	Symbol	Test Conditions	Min.	Typ. <sup>1</sup>	Max.	Unit <sup>2</sup>
Forward Supply Voltage	$V_{CC}$	Operating, $T_J < 165\text{ °C}$	4.0	-	24	V
Supply Current	$I_{CC}$	$V_{CC} = 4\text{ to }24\text{V}$	1.4	3.0	5.6	mA
Output Current	$I_{SINK}$	$V_{CC} = 4\text{ to }24\text{V}$	-	-	15	mA
Output Frequency	$f_{OUT}$	$V_{CC} = 4\text{ to }24\text{V}$	-	-	30	kHz

Higher output frequencies available upon request. Contact [sales@phoenixamerica.com](mailto:sales@phoenixamerica.com).

**Electrical Circuit**

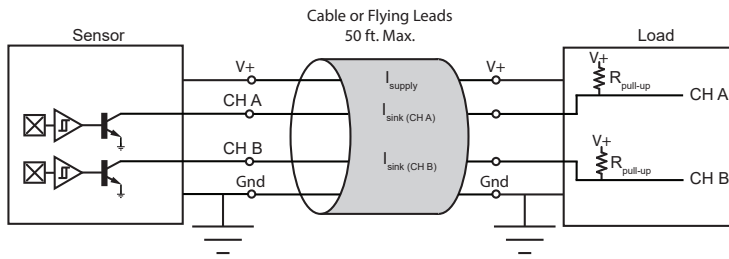

Output channels require customer supplied pull-up resistors unless internal pull-up option is selected. See Table 3.1 for recommended resistor values.

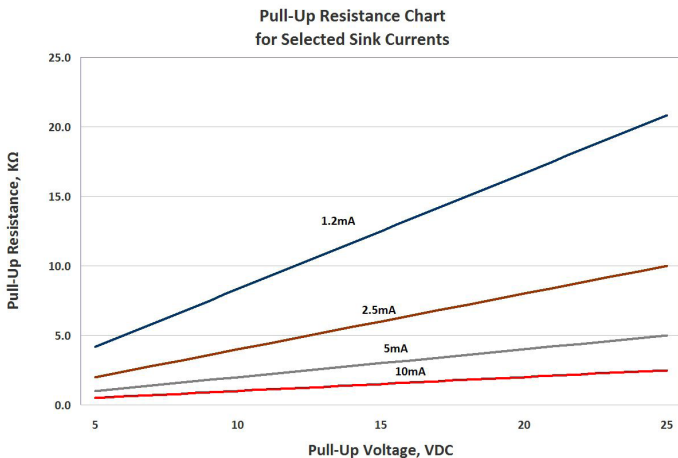

**Table 3.1**

Recommended Pull-Up Resistor Values			
	Supply Voltage		
Current, I <sub>sink</sub>	5	12	24
1.2 mA	4.3K	10.0K	20.0K
2.5 mA	2.0K	4.7K	10.0K
5 mA	1.0K	2.4K	4.7K
10 mA	510Ω	1.2K	2.4K

I<sub>sink</sub> is application dependent. It is recommended to use the lowest possible sink current when selecting a pull-up resistor.

Theoretical Pull-Up Resistor Calculation:  $R_{pullup} = \frac{V_{supply}}{I_{sink}}$

Resistance values based on closest standard 5% resistor values

Absolute Maximum I<sub>sink</sub> = 20mA

4.7 K pull-up is available as a standard option. If an alternative pull-up value is preferred, contact sales@phoenixamerica.com.

**Wiring**

FLYING LEADS

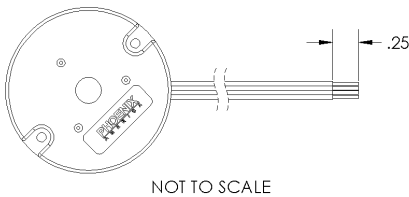

NOT TO SCALE

- 24 AWG
- 7x32 Strands, Tinned Copper
- PVC Insulation
- UL Type 1430
- Temperature Rating: 105°C

CABLE

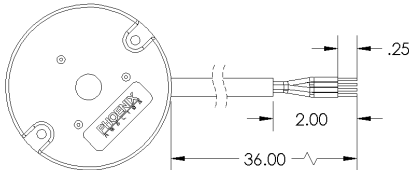

NOT TO SCALE

- 24 AWG
- 4 Conductor with Foil Shield and Drain
- Stranded Tinned Copper
- PVC Insulation
- Grey PVC Jacket
- UL Style 2464, CSA
- Temperature Rating: 105°C

**Table 3.2**

Standard Wiring			
	Leads	Cable	Connector Pin-Out
<b>Ch A</b>	Yellow	Brown	1
<b>Ch B</b>	Blue	Orange	2
<b>Gnd</b>	Black	Black	3
<b>Vcc</b>	Red	Red	4

Custom lengths and insulation materials available. Contact sales@phoenixamerica.com.

**Encoder Physical Outline**

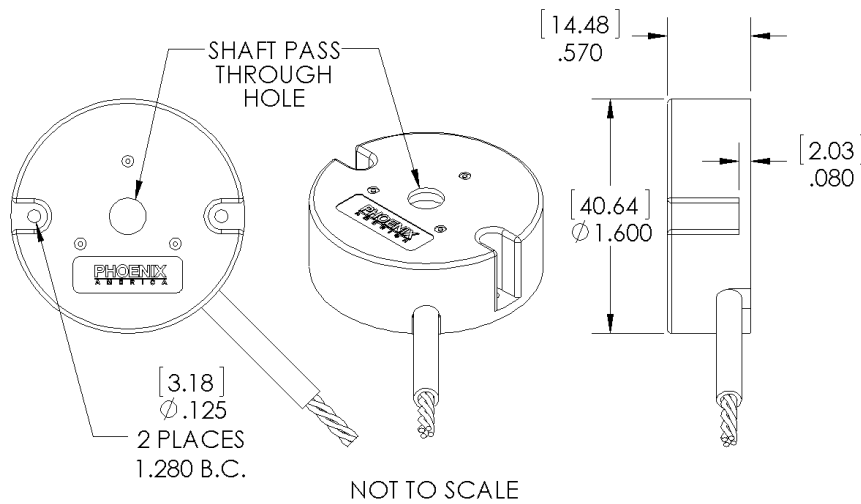

**Table 4.1**

Motor Shaft Diameter	Shaft Pass Through Hole Size (options/recommendation)	
-	No Hole	
2 mm	2.06 mm	0.081 in
3 mm	3.06 mm	0.120 in
1/8 in	3.26 mm	0.127 in
5/32 in	4.06 mm	0.160 in
4 mm	4.06 mm	0.160 in
3/16 in	4.83 mm	0.190 in
5 mm	5.06 mm	0.199 in
6 mm	6.06 mm	0.239 in
1/4 in	6.40 mm	0.252 in
7 mm	7.06 mm	0.278 in
5/16 in	8.05 mm	0.317 in
8 mm	8.05 mm	0.317 in
3/8 in	9.59 mm	0.378 in
10 mm	10.06 mm	0.396 in
12 mm	12.06 mm	0.475 in
1/2 in	12.76 mm	0.502 in

*Other shaft pass through hole sizes available upon request. Contact [sales@phoenixamerica.com](mailto:sales@phoenixamerica.com).*

**Encoder Mounting Guidelines**

*Concentricity of the encoder housing to the magnet rotor is critical for optimal encoder performance. Considering the following during the design phase will ensure concentricity and ease of assembly.*

- Tight molding tolerances allow for the outside diameter of the encoder to be used to locate the encoder housing concentric to the motor shaft and magnet rotor. A machined pocket on the motor endbell works well for alignment. Recommended pocket is 0.015" to 0.020" deep and 2.11" in diameter.
- Extending the shaft through the optional shaft pass through hole is an easy way to align the encoder housing to the motor shaft and magnet rotor. Simply position the encoder so that the shaft is centered concentrically in the shaft pass through hole.
- If previous two methods of alignment are not used it is recommended that the encoder be fastened to the motor using #5-40 or M3 mounting screws. The slightly larger diameter of the #5-40 and M3 screws will compensate for some of the tolerance allowed when using the standard recommended #4-40 or M2.5 mounting screws.

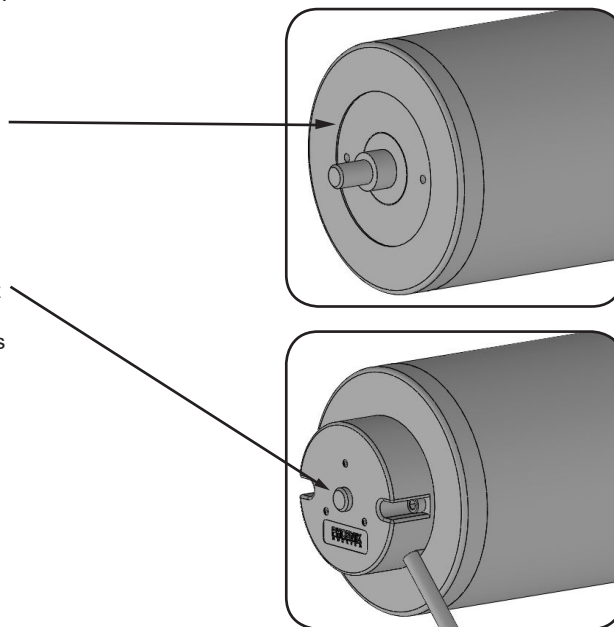

**Target Rotor Physical Outline - Molded (Mounting Style A)**

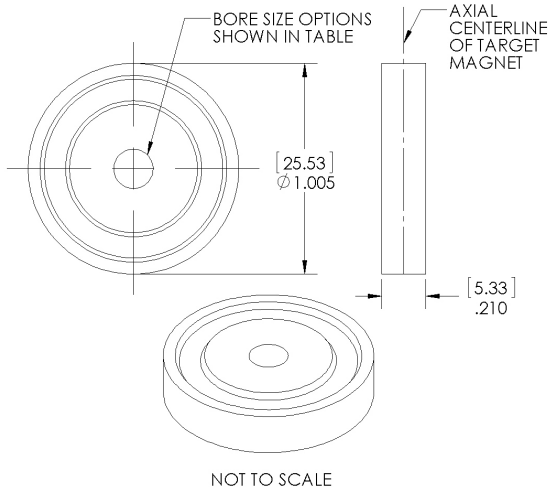

**Table 5.1**

Bore Size (.inch)	Motor Shaft OD Size (nominal)	NEMA Guide Shaft Tolerance	Magnet Bore MIN. (inch)	Magnet Bore MAX. (inch)
079	2 mm (.0787")	+0.0000"/-0.0005"	.0777	.0807
118	3 mm (.1181")		.1171	.1201
125	1/8 in (.1250")		.1240	.1270
156	5/32 in (.1563")		.1553	.1583
157	4 mm (.1575")		.1565	.1595
188	3/16 in (.1875")		.1865	.1895
197	5 mm (.1969")		.1959	.1989
236	6 mm (.2364")		.2354	.2384
250	1/4 in (.2500")		.2490	.2520
276	7 mm (.2758")		.2747	.2777
313	5/16 in (.3125")		.3115	.3145
315	8 mm (.3150")		.3140	.3170
375	3/8 in (.3750")		.3740	.3770
394	10 mm (.3940")		.3930	.3960
473	12 mm (.4728")		.4718	.4748
500	1/2 in (.5000")		.4990	.5020

Other bore sizes available upon request.  
Contact [sales@phoenixamerica.com](mailto:sales@phoenixamerica.com).

**Target Rotor Mounting Guidelines - Molded (Mounting Style A) For Slip Fit Application**

- Proper alignment of the target rotor to the encoder sensing element is critical for optimal encoder performance. Insure that the rotor is mounted to the specified height shown in the diagram below.
- A machined step on the motor shaft provides a quick and repeatable method for positioning the target rotor. Spacers or other fixturing should be used to properly position the rotor if no mechanical locating features are on the shaft.
- Various adhesives can be used to bond the target rotor to the motor shaft. Shaft alloys, operating environment, and shaft speed and acceleration should be taken into consideration when selecting an appropriate bonding agent. Loctite threadlockers and retaining compounds have proved effective in bonding the target rotor to the motor shaft. Loctite 263 and 2760 threadlockers and Loctite 638 and 680 retaining compounds are good candidates. These materials have been effective in past experience; testing under actual operating conditions should be used to qualify any bonding material.
- For best results, the motor shaft should be clean and free of any oils, lubricants, or solvents.
- Apply adhesive around the leading edge of the shaft and inside the hole in the rotor. Use a rotating motion when assembling the magnet to the shaft to insure good adhesive coverage.
- The use of primers and activators can be used to improve bond strength and cure rate.
- For non-critical applications or for fast bonding for evaluation, a cyanoacrylate adhesive (super glue) can be used. Loctite 401 and 410 have proven effective for quick bonding applications.

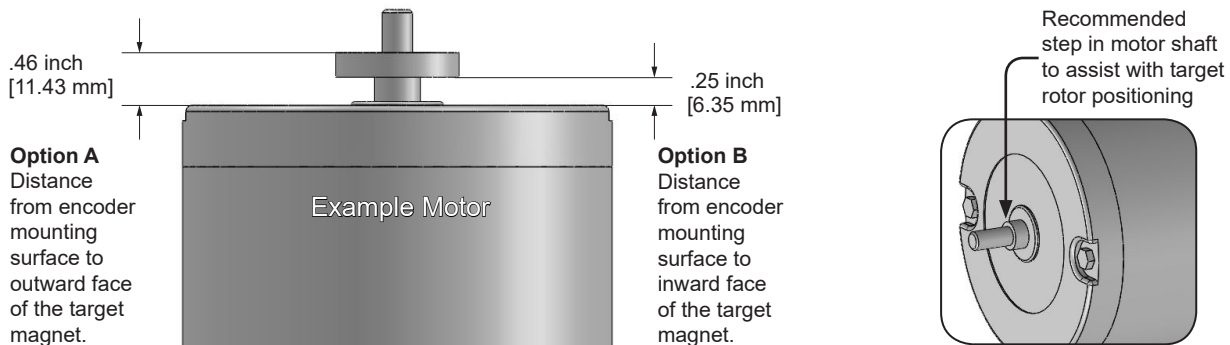

**Target Rotor Physical Outline - Aluminum Hub (Mounting Style B)**

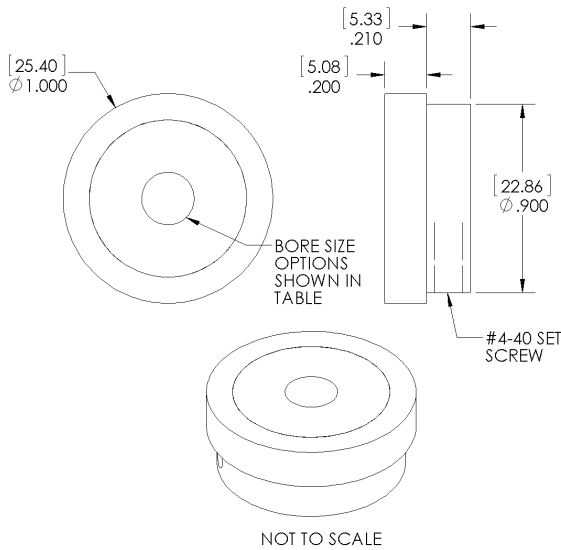

**Table 6.1**

Bore Size (.inch)	Motor Shaft OD Size (nominal)	NEMA Guide Shaft Tolerance	Magnet Bore MIN. (inch)	Magnet Bore MAX. (inch)
079	2 mm (.0787")	+0.0000"/-0.0005"	.0794	.0803
118	3 mm (.1181")		.1188	.1197
125	1/8 in (.1250")		.1257	.1266
156	5/32 in (.1563")		.1570	.1579
157	4 mm (.1575")		.1582	.1591
188	3/16 in (.1875")		.1882	.1891
197	5 mm (.1969")		.1976	.1985
236	6 mm (.2364")		.2371	.2380
250	1/4 in (.2500")		.2507	.2516
276	7 mm (.2758")		.2767	.2778
313	5/16 in (.3125")		.3134	.3145
315	8 mm (.3150")		.3159	.3170
375	3/8 in (.3750")		.3759	.3770
394	10 mm (.3940")		.3949	.3960
473	12 mm (.4728")		.4737	.4748
500	1/2 in (.5000")		.5009	.5020

Other bore sizes available upon request.  
Contact [sales@phoenixamerica.com](mailto:sales@phoenixamerica.com).

**Target Rotor Mounting Guidelines - Aluminum Hub (Mounting Style B)**

- Proper alignment of the target rotor to the encoder sensing element is critical for optimal encoder performance. Insure that the rotor is mounted to the specified height shown in the diagram below.
- A machined step on the motor shaft provides a quick and repeatable method for positioning the target rotor. Spacers or other fixturing should be used to properly position the rotor if no mechanical locating features are on the shaft.
- While the hub is held in the proper position, use a .50 inch hex wrench to tighten #4-40 set screw.
- For permanent applications, a threadlocker or retaining compound is advised in conjunction with the set screw.

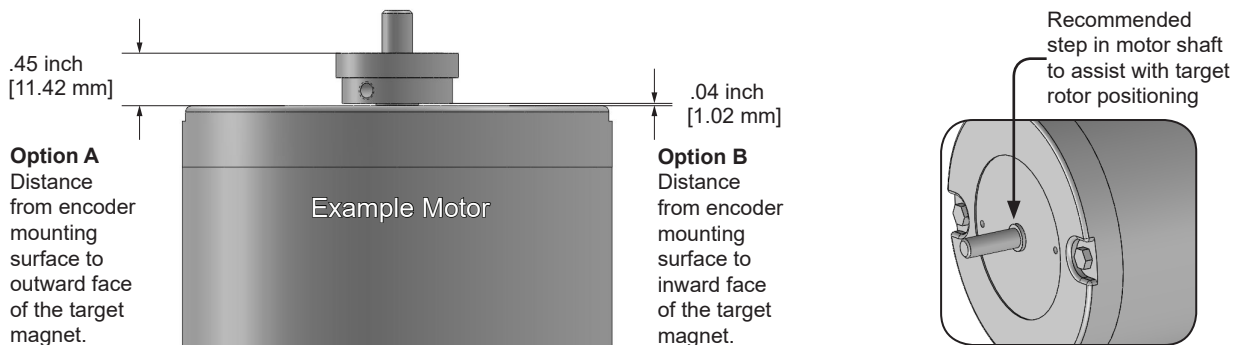

**Target Rotor Physical Outline - Engineered Polymer Hub (Mounting Style H)**

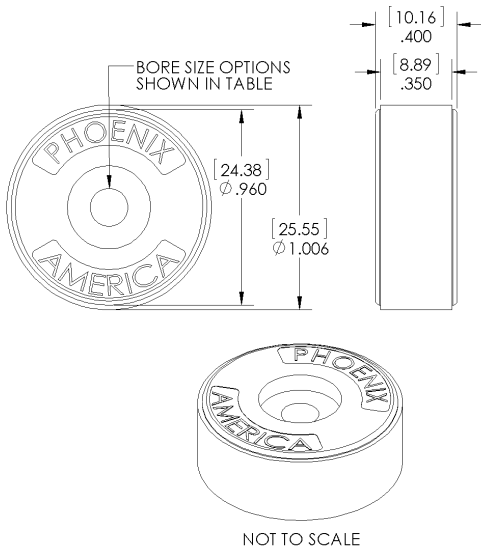

**Table 7.1**

Bore Size (.inch)	Motor Shaft OD Size (nominal)	NEMA Guide Shaft Tolerance	Magnet Bore MIN. (inch)	Magnet Bore MAX. (inch)
079	2 mm (.0787")	+0.0000"/-0.0005"	.0727	.0757
118	3 mm (.1181")		.1121	.1151
125	1/8 in (.1250")		.1190	.1220
156	5/32 in (.1563")		.1503	.1533
157	4 mm (.1575")		.1515	.1545
188	3/16 in (.1875")		.1815	.1845
197	5 mm (.1969")		.1909	.1939
236	6 mm (.2364")		.2304	.2334
250	1/4 in (.2500")		.2440	.2470
276	7 mm (.2758")		.2698	.2728
313	5/16 in (.3125")		.3065	.3095
315	8 mm (.3150")		.3090	.3120
375	3/8 in (.3750")		.3690	.3720
394	10 mm (.3940")		.3880	.3910
473	12 mm (.4728")		.4668	.4698
500	1/2 in (.5000")		.4940	.4970

Other bore sizes available upon request.  
Contact [sales@phoenixamerica.com](mailto:sales@phoenixamerica.com).

**Target Rotor Mounting Guidelines - Engineered Polymer Hub (Mounting Style H) For Press Fit Application**

- Proper alignment of the target rotor to the encoder sensing element is critical for optimal encoder performance. Insure that the rotor is mounted to the specified height shown below.
- A machined step on the motor shaft provides a quick and repeatable method for positioning the target rotor. Spacers or other fixturing should be used if no mechanical locating features are on the shaft.
- A chamfered lead in on the shaft will aid in aligning the rotor.
- Prior to insertion, the motor shaft should be clean and free of any oils, lubricants, or solvents.
- Proper fixtures and support must be used to ensure the magnet is pressed on straight and aligned with the motor shaft.
- Opposite end of motor shaft should be supported to avoid undue stress on motor bearings during the pressing operation.
- In applications with high torque or environmental extremes, a retaining compound can be used to enhance the strength of the press fit.

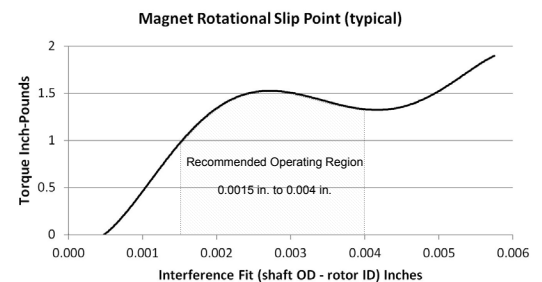
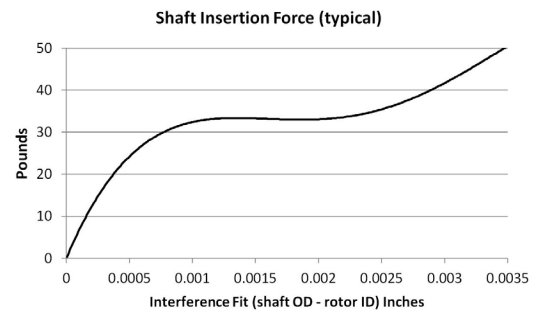



**Connector Options**

Molex Mini-Fit Jr. (Male)

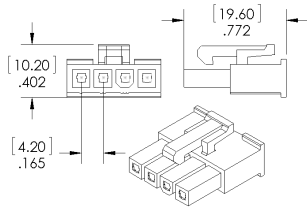

Molex Mini-Fit Jr. (Female)

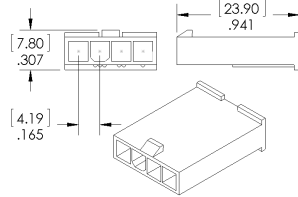

TE AmpModu MTE (Male)

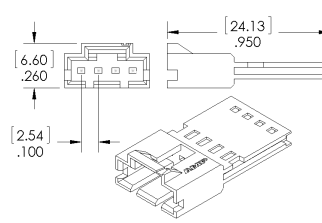

TE AmpModu MTE (Female)

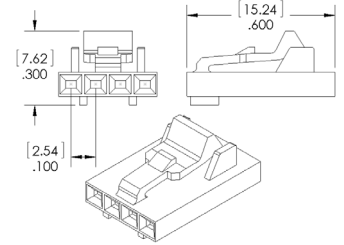

Need a different connector? Contact [sales@phoenixamerica.com](mailto:sales@phoenixamerica.com).

**Part Number Description**

L6 - 30 - 188 - N - C - N - A - F - B - X									
Series	PPR	Bore Size	Index	Output Type	Shaft Pass Through Hole	Target Magnet Mounting	Wiring	Length (Meters)	Connector
L6	1	079 2 mm	N A,B Quadrature (default)	C Open Collector (default)  P Open Collector with Internal Pull-Up (4.7K)	N None (default)  Y Size will match bore shown in Table 4.1	A Molded (default)  B Aluminum Hub  H Engineered Polymer Hub	F Flying Leads (default)  C Cable	A .5 (19.685") B 0.914 (36") (default) C 1 (39.370") D 2 (78.740")	X None (default) A1 TE AmpModu MTE (Male) A2 TE AmpModu MTE (Female) (default) M1 Molex Mini-Fit Jr. (Male) M2 Molex Mini-Fit Jr. (Female)
	2	118 3 mm							
	3	125 1/8 in							
	4	156 5/32 in							
	5	157 4 mm							
	6	188 3/16 in (default)							
	7	197 5 mm							
	8	236 6 mm							
	9	250 1/4 in							
	10	276 7 mm							
	12	313 5/16 in							
	14	315 8 mm							
	15	375 3/8 in							
	16	394 10 mm							
	17	473 12 mm							
	18	500 1/2 in							
	19								
	20								
	22								
	25								
	26								
	30								

Example: L6-30-188-N-C-N-A-F-B-X