

Features and Benefits

- 30 mm O.D. Miniature size
- Magnetic technology offers robust performance.
- 100% Non-contacting design (no bearings or bushing) provides an extremely long life expectancy and is tolerant to harsh environments.
- Simple two piece design (target magnet + encoder) for easy alignment and installation.
- Bi-directional two channel incremental quadrature output. Option for differential RS422 compatible output.
- Mounting holes for 2-bolt (.750 in B.C. x .125 in O.D.) or 3-bolt pattern (.823 in B.C x .078 inch O.D.)
- Target magnet for standard shaft sizes from 2 mm to 3/8 inch. Custom bore size available.
- Options for 10 to 1280 pulse per channel per revolution (*increments of 10*).
- Customizable lead wires, cables, and or connectors.

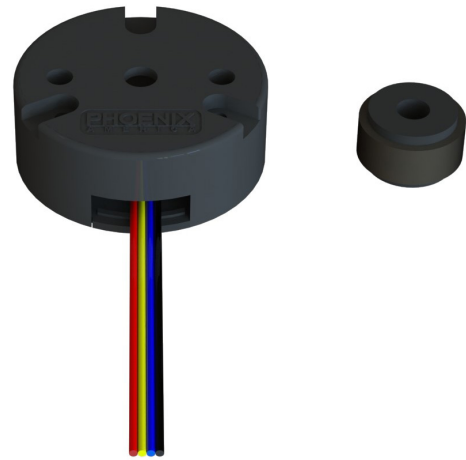

Kit - Encoder with Target Magnet
Shown with shaft pass through hole and single ended wiring
Wire color order varies with part configuration

Application Example

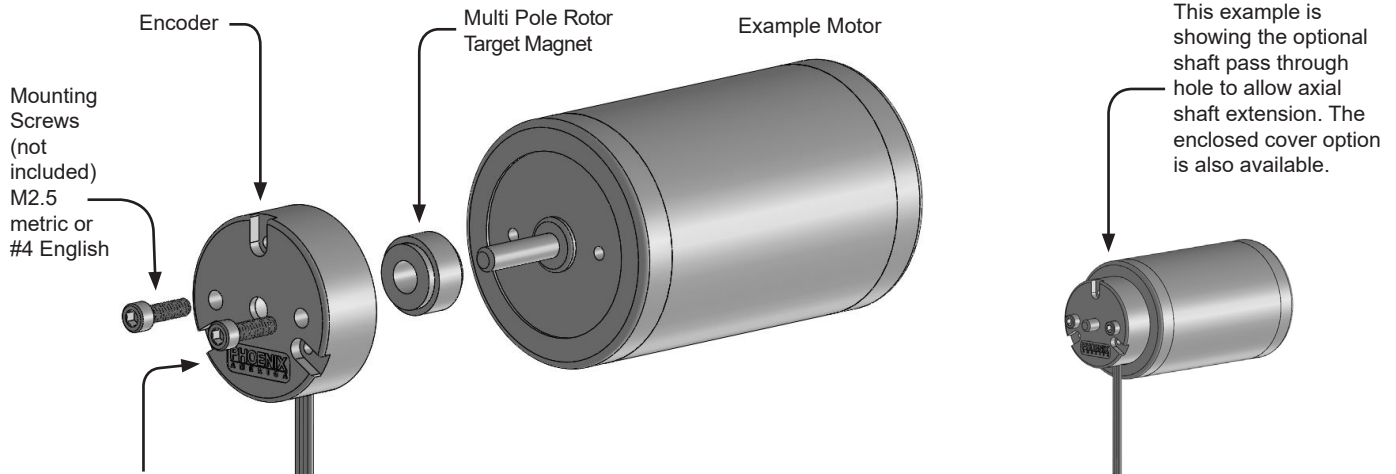
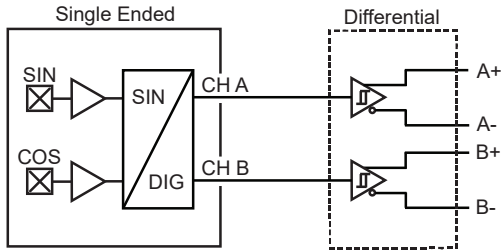

Table 1.1

Standard Wiring Color Code				
		Flying Leads	Cable	
Differential	Single Ended	Vcc	Red	
		Gnd	Black	
		Ch A	Yellow	
	Ch B	Blue		
	Differential	Ch A-	Brown	Yellow
		Ch B-	Orange	Green

Other colors available upon request.
Contact sales@phoenixamerica.com.

Electrical Circuit



Absolute Maximum Ratings

Table 2.1

Characteristic	Symbol	Rating for 5V	Rating for 6V to 25V	Units
Forward Supply Voltage	V_{CC}	6	30	V
Reverse Supply Voltage	V_{RCC}	-0.3	-20	V
Storage Temperature	T_S	150	150	°C
ESD (HMB, 100pF/1.5Kohm)		2	2	kV

Specifications - 5V Supply

Table 2.2

Characteristic	Symbol	Test Conditions	Min.	Typ.	Max.	Unit
Supply Voltage	V_{CC}	Operating, $T_J < 165\text{ °C}$	4.75	5	5.5	V
Supply Current	I_{CC}	$V_{CC} = 12V$	-	15	24	mA
Operating Temperature	T_A		-40	-	125	°C
Duty Cycle	-		40	50	60	%
Phase	-		70	90	110	°e
Output Frequency	f_{out}		-	-	300	kHz

Specifications - 24V Supply

Table 2.3

Characteristic	Symbol	Test Conditions	Min.	Typ.	Max.	Unit
Supply Voltage	V_{CC}	Operating, $T_J < 165\text{ °C}$	5.0	12	24	V
Supply Current	I_{CC}	$V_{CC} = 12V$	-	15	25	mA
Operating Temperature	T_A		-40	-	125	°C
Duty Cycle	-		40	50	60	%
Phase	-		70	90	110	°e
Output Frequency	f_{out}		-	-	300	kHz

Higher output frequencies available upon request. Contact sales@phoenixamerica.com.

Output Waveforms

Single Ended

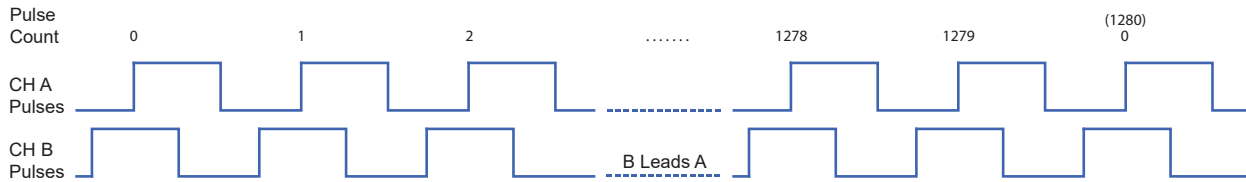
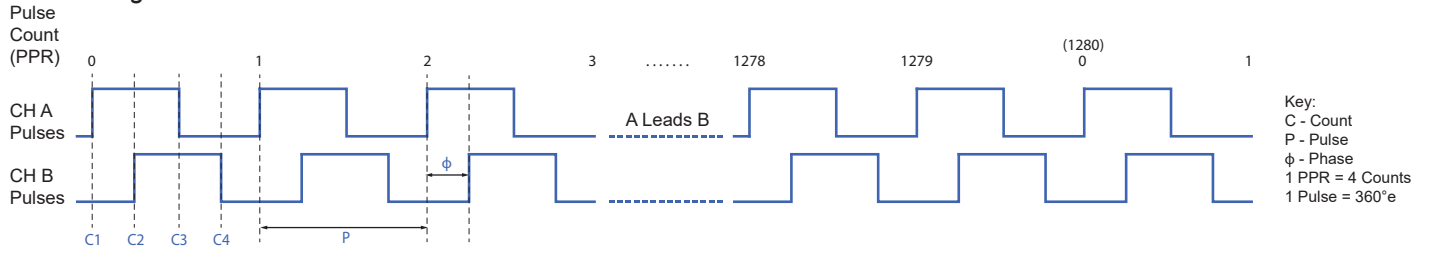

Differential

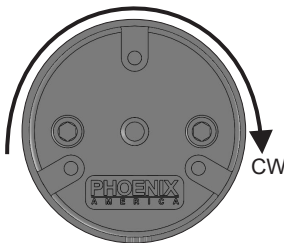
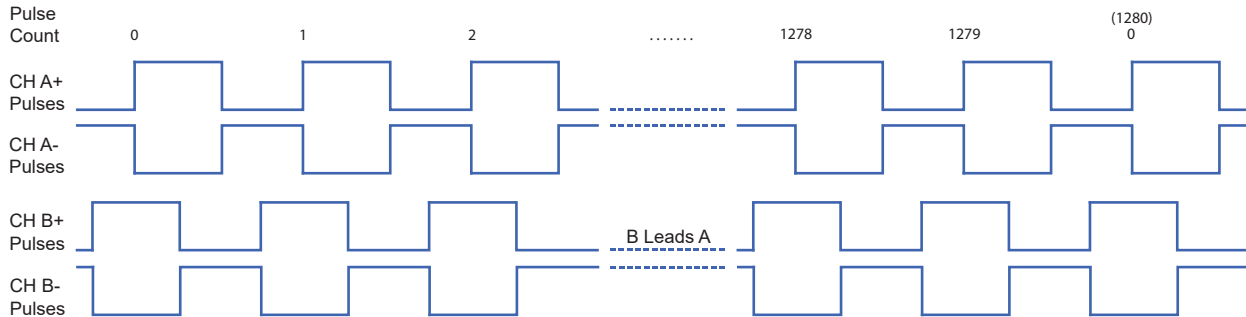
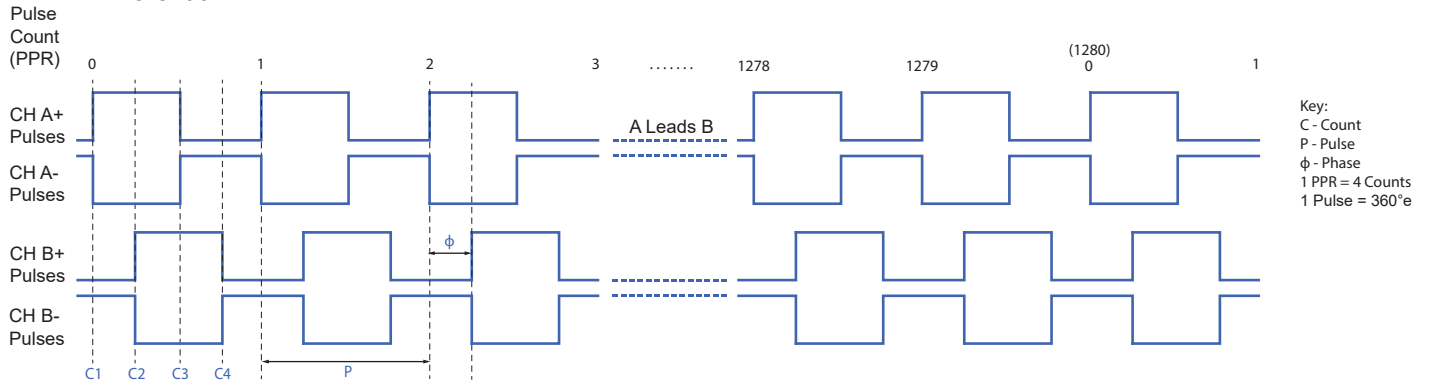

Channel A leads Channel B for clockwise shaft rotation (shaft rotation is defined when looking at the branded face of the encoder).

Encoder Physical Outline

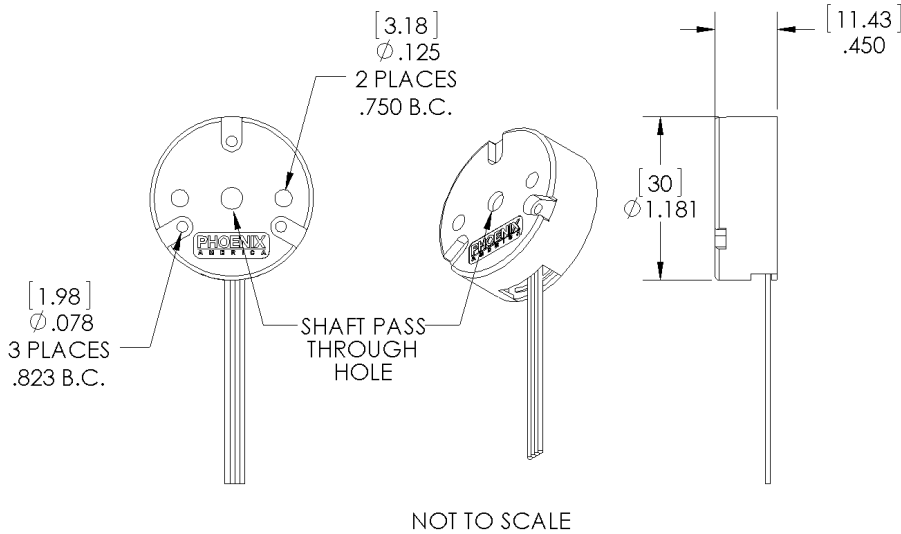

Table 4.1

Motor Shaft Diameter	Shaft Pass Through Hole Size (options/recommendation)	
-	No Hole	
2 mm	2.06 mm	0.081 in
3 mm	3.06 mm	0.120 in
1/8 in	3.26 mm	0.127 in
5/32 in	4.06 mm	0.160 in
4 mm	4.06 mm	0.160 in
3/16 in	4.83 mm	0.190 in
5 mm	5.06 mm	0.199 in
6 mm	6.06 mm	0.239 in
1/4 in	6.40 mm	0.252 in
7 mm	7.06 mm	0.278 in
5/16 in	8.05 mm	0.317 in
8 mm	8.05 mm	0.317 in
3/8 in	9.59 mm	0.378 in

Other shaft pass through hole sizes available upon request. Contact sales@phoenixamerica.com.

Encoder Mounting Guidelines

Concentricity of the encoder housing to the magnet rotor is critical for optimal encoder performance. Considering the following during the design phase will ensure concentricity and ease of assembly.

- Tight molding tolerances allow for the outside diameter of the encoder to be used to locate the encoder housing concentric to the motor shaft and magnet rotor. A machined pocket on the motor endbell works well for alignment. Recommended pocket is 0.015" to 0.020" deep and 2.11" in diameter.
- Extending the shaft through the optional shaft pass through hole is an easy way to align the encoder housing to the motor shaft and magnet rotor. Simply position the encoder so that the shaft is centered concentrically in the shaft pass through hole.
- If previous two methods of alignment are not used it is recommended that the encoder be fastened to the motor using #5-40 or M3 mounting screws. The slightly larger diameter of the #5-40 and M3 screws will compensate for some of the tolerance allowed when using the standard recommended #4-40 or M2.5 mounting screws.

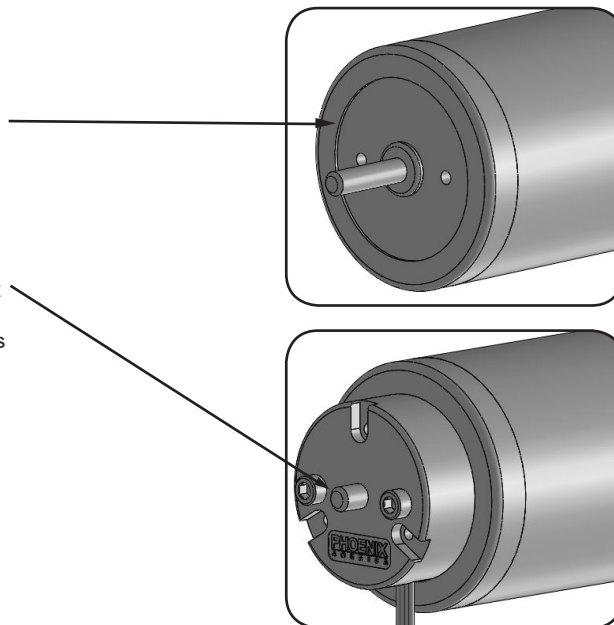

Target Rotor Physical Outline - Engineered Polymer Hub (Mounting Style H)

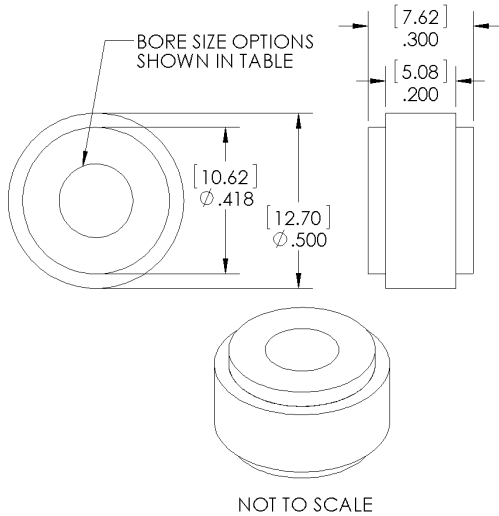

Table 5.1

Bore Size (.inch)	Motor Shaft OD Size (nominal)	NEMA Guide Shaft Tolerance	Magnet Bore MIN. (inch)	Magnet Bore MAX. (inch)
079	2 mm (.0787")	+0.0000"/-0.0005"	.0727	.0757
118	3 mm (.1181")		.1121	.1151
125	1/8 in (.1250")		.1190	.1220
156	5/32 in (.1563")		.1503	.1533
157	4 mm (.1575")		.1515	.1545
188	3/16 in (.1875")		.1815	.1845
197	5 mm (.1969")		.1909	.1939
236	6 mm (.2364")		.2304	.2334
250	1/4 in (.2500")		.2440	.2470
276	7 mm (.2758")		.2698	.2728
313	5/16 in (.3125")		.3065	.3095
315	8 mm (.3150")		.3090	.3120
375	3/8 in (.3750")		.3690	.3720

Other bore sizes available upon request.
Contact sales@phoenixamerica.com.

Target Rotor Mounting Guidelines - Engineered Polymer Hub (Mounting Style H) For Press Fit Application

- Proper alignment of the target rotor to the encoder sensing element is critical for optimal encoder performance. Insure that the rotor is mounted to the specified height shown below.
- A machined step on the motor shaft provides a quick and repeatable method for positioning the target rotor. Spacers or other fixturing should be used if no mechanical locating features are on the shaft.
- A chamfered lead in on the shaft will aid in aligning the rotor.
- Prior to insertion, the motor shaft should be clean and free of any oils, lubricants, or solvents.
- Proper fixtures and support must be used to ensure the magnet is pressed on straight and aligned with the motor shaft.
- Opposite end of motor shaft should be supported to avoid undue stress on motor bearings during the pressing operation.
- In applications with high torque or environmental extremes, a retaining compound can be used to enhance the strength of the press fit.

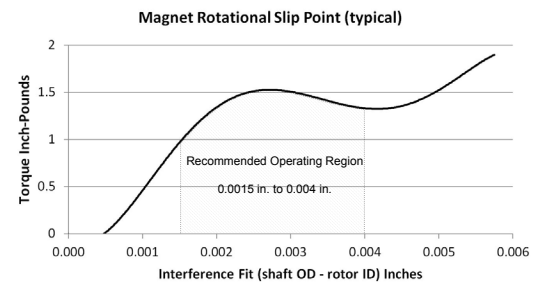
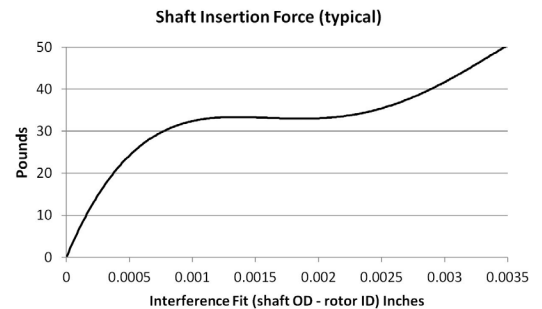

Wiring (Single ended option depicted)

FLYING LEADS

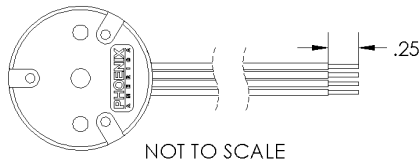

- 24 AWG
- 7x32 Strands, Tinned Copper
- PVC Insulation
- UL Type 1430
- Temperature Rating: 105°C

CABLE

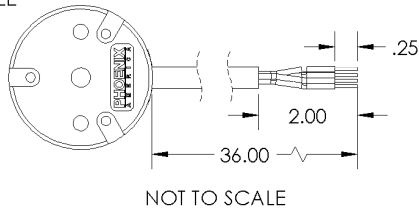

- 24 (or 26) AWG
- 4 (or 6) Conductor with Foil Shield and Drain
- Stranded Tinned Copper
- PVC Insulation
- Grey PVC Jacket
- UL Style 2464, CSA
- Temperature Rating: 105°C

Table 6.1

Single Ended Wiring			
	Leads	Cable	Connector Pin-Out
Ch A	Yellow	Brown	1
Ch B	Blue	Orange	2
Gnd	Black	Black	3
Vcc	Red	Red	4
Differential Wiring			
	Leads	Cable	Connector Pin-Out
Ch B	Blue	Orange	1
Ch B-	Orange	Green	2
Ch A	Yellow	Brown	3
Ch A-	Brown	Yellow	4
Gnd	Black	Black	5
Vcc	Red	Red	6

Custom lengths and insulation materials available. Contact sales@phoenixamerica.com.

Connector Options (Single ended option depicted)

Molex Mini-Fit Jr. (Male)

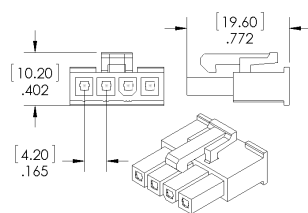

Molex Mini-Fit Jr. (Female)

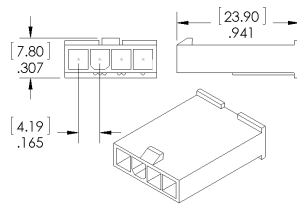

TE AmpModu MTE (Male)

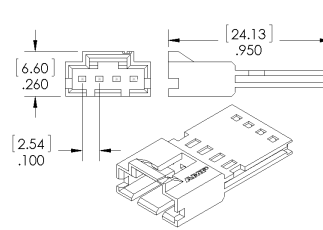

TE AmpModu MTE (Female)

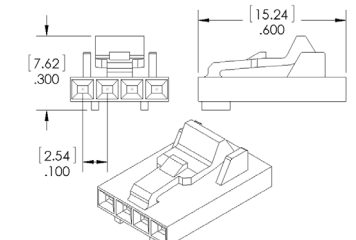

Need a different connector? Contact sales@phoenixamerica.com.

Part Number Description

HB-20-188-05-N-S-N-H-F-B-X

Series	PPR	Bore Size	Supply Voltage	Index	Output Type	Shaft Pass Through Hole	Target Magnet Mounting	Wiring	Length (Meters)	Connector
HB	10 20 30 40 . . 1200	079 2 mm 118 3 mm 125 1/8 in 156 5/32 in 157 4 mm 188 3/16 in (default) 197 5 mm 236 6 mm 250 1/4 in 276 7 mm 313 5/16 in 315 8 mm 375 3/8 in	05 5 V (default) 24 24 V	N A,B Quadrature (default)	S Single-Ended (default) D Differential	N None (default) Y Hole size will match Table 4.1	H Engineered Polymer Hub	F Flying Leads (default) C Cable	A 5 (19.685") B 0.914 (36") (default) C 1 (39.370") D 2 (78.740")	X None (default) A1 TE AmpModu MTE (Male) A2 TE AmpModu MTE (Female) M1 Molex Mini-Fit Jr. (Male) M2 Molex Mini-Fit Jr. (Female)

Example: HB-20-188-05-N-S-N-H-F-B-X