

# NFVA33065L32

## ASPM 27 Series

### 3-Phase 650 V, 30 A Automotive Smart Power Module

#### General Description

NFVA33065L32 is an advanced Automotive SPM<sup>®</sup> module providing a fully-featured, high-performance inverter output stage for hybrid and electric vehicles. These modules integrate optimized gate drive of the built-in IGBTs to minimize EMI and losses, while also providing multiple on-module protection features including under-voltage lockouts, over-current shutdown, thermal monitoring of drive IC, and fault reporting. The built-in, high-speed HVIC requires only a single supply voltage and translates the incoming logic-level gate inputs to the high-voltage, high-current drive signals required to properly drive the module's internal IGBTs. Separate negative IGBT terminals are available for each phase to support the widest variety of control algorithms.

#### Features

- Automotive SPM in 27 pin DIP package
- AEC & AQC324 Qualified and PPAP Capable
- 650 V/30 A 3-Phase IGBT Inverter with Integral Gate Drivers and Protections
- 175°C guaranteed Short-Circuit Rated FS Trench IGBTs with stable EMI performance
- Outstanding Thermal Resistance using Al<sub>2</sub>O<sub>3</sub> DBC Substrate
- Separated Open-Emitter Pins from Low-Side IGBTs for Three-Phase Current Sensing
- Single-Grounded Power Supply
- LVIC Temperature-Sensing Built-In for Temperature Monitoring
- Isolation Rating: 2500 V<sub>rms</sub>/1 min.
- Pb-Free and RoHS compliant

#### Applications

- Automotive high voltage auxiliary motors
  - ◆ Climate e-Compressors
  - ◆ Oil/Water Pumps
  - ◆ Super/Turbo Chargers
  - ◆ Variety Fans

#### Related Resources

- [AND9800](#) – Automotive Smart Power Module, 650 V ASPM27 Series
- [AN-9086](#) – SPM 3 Package Mounting Guidance

#### Integrated Power Functions

- 650 V–30 A IGBT inverter for three-phase DC/AC power conversion (Refer to Figure 2)



ON Semiconductor<sup>®</sup>

[www.onsemi.com](http://www.onsemi.com)

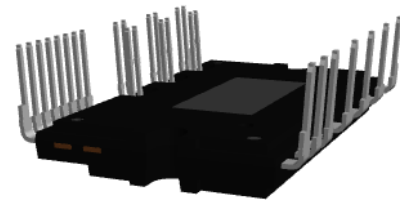

3D Package Drawing  
(Click to Activate 3D Content)

ASPM27-CCA  
CASE MODFJ

#### MARKING DIAGRAM

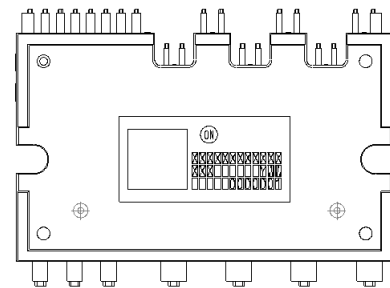

ON	= ON Semiconductor Logo
XXXXXXXXXXXX	= Specific Device Code
XXX	= Lot Number
Y	= Year
WW	= Work Week
000001	= Serial Number

#### ORDERING INFORMATION

See detailed ordering and shipping information on page 6 of this data sheet.

# NFVA33065L32

## Integrated Drive, Protection and System Control Functions

- For inverter high-side IGBTs: gate drive circuit, high-voltage isolated high-speed level shifting control circuit, Under-Voltage Lock-Out (UVLO) protection
- For inverter low-side IGBTs: gate drive circuit, Short-Circuit Protection (SCP) control circuit, Under-Voltage Lock-Out Protection (UVLO)
- Fault signaling: corresponding to UVLO (low-side supply) and SC faults
- Input interface: active-HIGH interface, works with 3.3/5 V logic, Schmitt-trigger input

### PIN CONFIGURATION

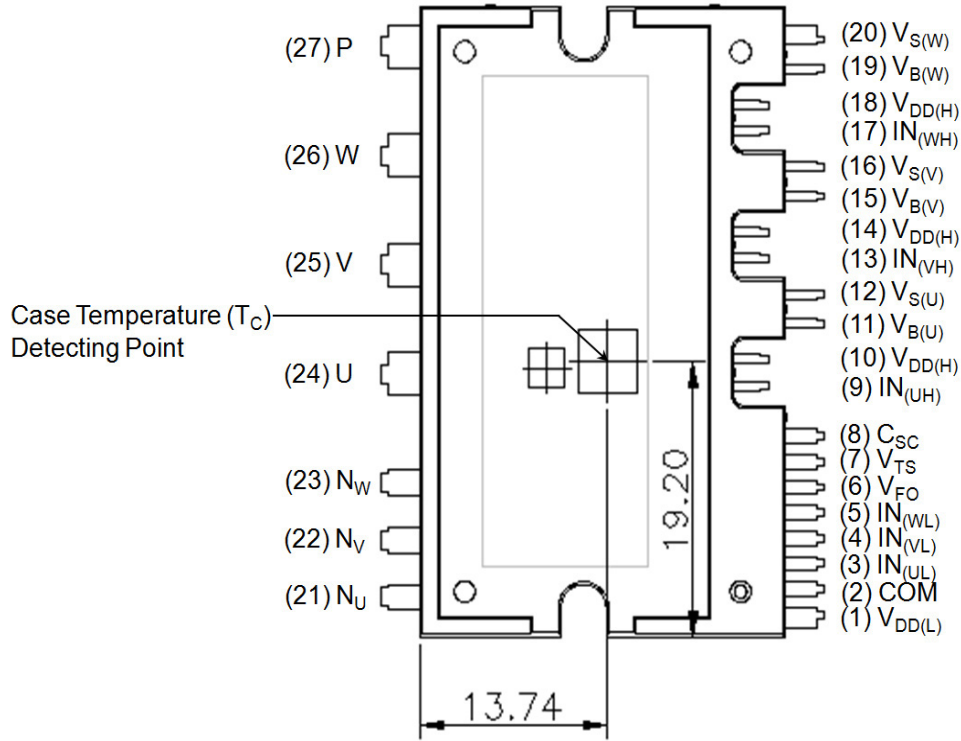

Figure 1. Top View

## NFVA33065L32

### PIN DESCRIPTIONS

Pin Number	Pin Name	Pin Description
1	V <sub>DD(L)</sub>	Low-Side Common Bias Voltage for IC and IGBTs Driving
2	COM	Common Supply Ground
3	IN <sub>(UL)</sub>	Signal Input for Low-Side U-Phase
4	IN <sub>(VL)</sub>	Signal Input for Low-Side V-Phase
5	IN <sub>(WL)</sub>	Signal Input for Low-Side W-Phase
6	V <sub>FO</sub>	Fault Output
7	V <sub>TS</sub>	Output for LVIC Temperature Sensing Voltage Output
8	C <sub>SC</sub>	Shut Down Input for Short-Circuit Current Detection Input
9	IN <sub>(UH)</sub>	Signal Input for High-Side V-Phase
10	V <sub>DD(H)</sub>	High-Side Common Bias Voltage for IC and IGBTs Driving
11	V <sub>B(U)</sub>	High-Side Bias Voltage for U-Phase IGBT Driving
12	V <sub>S(U)</sub>	High-Side Bias Voltage Ground for U-Phase IGBT Driving
13	IN <sub>(VH)</sub>	Signal Input for High-Side V-Phase
14	V <sub>DD(H)</sub>	High-Side Common Bias Voltage for IC and IGBTs Driving
15	V <sub>B(V)</sub>	High-Side Bias Voltage for V-Phase IGBT Driving
16	V <sub>S(V)</sub>	High-Side Bias Voltage Ground for V-Phase IGBT Driving
17	IN <sub>(WH)</sub>	Signal Input for High-Side W-Phase
18	V <sub>DD(H)</sub>	High-Side Common Bias Voltage for IC and IGBTs Driving
19	V <sub>B(W)</sub>	High-Side Bias Voltage for W-Phase IGBT Driving
20	V <sub>S(W)</sub>	High-Side Bias Voltage Ground for W-Phase IGBT Driving
21	N <sub>U</sub>	Negative DC-Link Input for U-Phase
22	N <sub>V</sub>	Negative DC-Link Input for V-Phase
23	N <sub>W</sub>	Negative DC-Link Input for W-Phase
24	U	Output for U-Phase
25	V	Output for V-Phase
26	W	Output for W-Phase
27	P	Positive DC-Link Input

# NFVA33065L32

## INTERNAL EQUIVALENT CIRCUIT AND INPUT/OUTPUT PINS

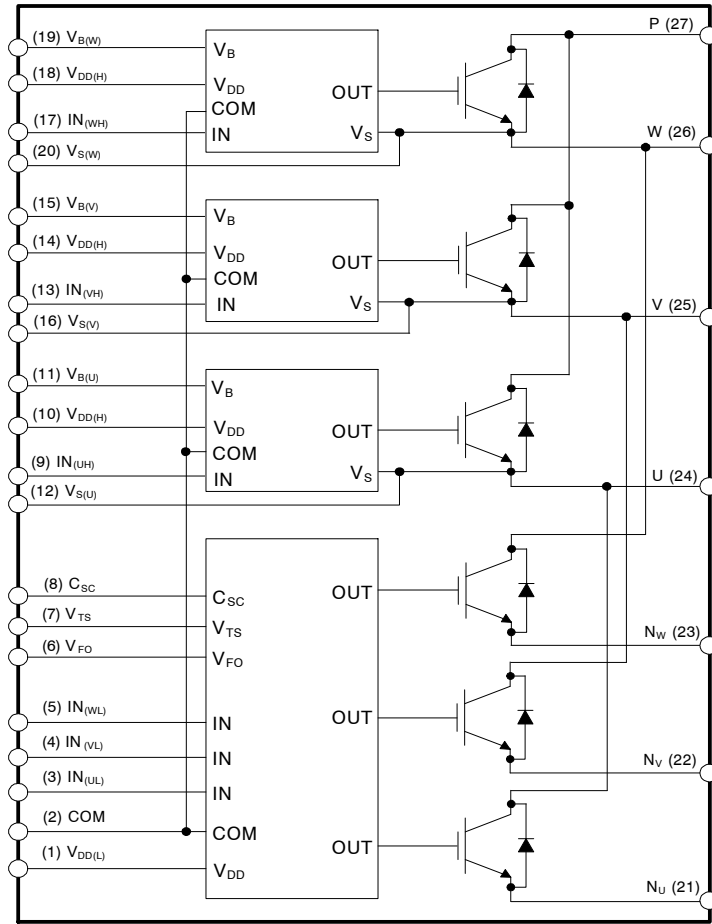

**NOTES:**

1. Inverter low-side is composed of three IGBTs, freewheeling diodes for each IGBT, and one control IC. It has gate drive and protection functions.
2. Inverter power side is composed of four inverter DC-link input terminals and three inverter output terminals.
3. Inverter high-side is composed of three IGBTs, freewheeling diodes, and three drive ICs for each IGBT.

**Figure 2. Internal Block Diagram**

# NFVA33065L32

## ABSOLUTE MAXIMUM RATINGS ( $T_J = 25^\circ\text{C}$ unless otherwise noted)

Symbol	Parameter	Conditions	Rating	Unit
<b>INVERTER PART</b>				
$V_{PN}$	Supply Voltage	Applied between P-N <sub>U</sub> , N <sub>V</sub> , N <sub>W</sub>	500	V
$V_{PN(\text{Surge})}$	Supply Voltage (Surge)	Applied between P-N <sub>U</sub> , N <sub>V</sub> , N <sub>W</sub>	550	V
$V_{CES}$	Collector-Emitter Voltage		650	V
$\pm I_C$	Each IGBT Collector Current	$T_C = 100^\circ\text{C}$ , $V_{DD} \geq 15\text{ V}$ , $T_J \leq 175^\circ\text{C}$ (Note 4)	30	A
$\pm I_{CP}$	Each IGBT Collector Current (Peak)	$T_C = 25^\circ\text{C}$ , $T_J \leq 175^\circ\text{C}$ , Under 1 ms Pulse Width (Note 4)	60	A
$P_C$	Collector Dissipation	$T_C = 25^\circ\text{C}$ per One Chip (Note 4)	96	W
$T_J$	Operating Junction Temperature	IGBT and Diode	-40~175	°C
		Driver IC	-40~150	

## CONTROL PART

$V_{DD}$	Control Supply Voltage	Applied between $V_{DD(H)}$ , $V_{DD(L)}$ -COM	20	V
$V_{BS}$	High-Side Control Bias Voltage	Applied between $V_{B(U)}$ - $V_{S(U)}$ , $V_{B(V)}$ - $V_{S(V)}$ , $V_{B(W)}$ - $V_{S(W)}$	20	V
$V_{IN}$	Input Signal Voltage	Applied between $IN_{(UH)}$ , $IN_{(VH)}$ , $IN_{(WH)}$ , $IN_{(UL)}$ , $IN_{(VL)}$ , $IN_{(WL)}$ -COM	-0.3- $V_{DD}+0.3$	V
$V_{FO}$	Fault Output Supply Voltage	Applied between $V_{FO}$ -COM	-0.3- $V_{DD}+0.3$	V
$I_{FO}$	Fault Output Current	Sink Current at $V_{FO}$ pin	2	mA
$V_{SC}$	Current Sensing Input Voltage	Applied between $C_{SC}$ -COM	-0.3- $V_{DD}+0.3$	V

## TOTAL SYSTEM

$t_{SC}$	Short Circuit Withstand Time	$V_{DD} = V_{BS} \leq 16.5\text{ V}$ , $V_{PN} \leq 400\text{ V}$ , $T_J = 150^\circ\text{C}$ Non-repetitive	3	$\mu\text{s}$
$T_{STG}$	Storage Temperature		-55~175	°C
$V_{ISO}$	Isolation Voltage	60 Hz, Sinusoidal, AC 1 minute, Connection Pins to Heat Sink Plate	2500	$V_{rms}$

## THERMAL RESISTANCE

Symbol	Parameter	Conditions	Min.	Typ.	Max.	Unit
$R_{th(j-c)Q}$	Junction to Case Thermal Resistance (Note 5)	Inverter IGBT part (per 1/6 module)	-	-	1.55	°C/W
$R_{th(j-c)F}$		Inverter FWD part (per 1/6 module)	-	-	2.60	°C/W
$L_\sigma$	Package Stray Inductance	P to N <sub>U</sub> , N <sub>V</sub> , N <sub>W</sub> (Note 5)	-	24	-	nH

4. These values had been made an acquisition by the calculation considered to design factor.

5. For the measurement point of case temperature ( $T_C$ ), please refer to Figure 1. DBC discoloration and Picker Circle Printing allowed, please refer to application note [AN-9190](#) (Impact of DBC Oxidation on SPM<sup>®</sup> Module Performance).

6. Stray inductance per phase measured per IEC 60747-15.

# NFVA33065L32

## ELECTRICAL CHARACTERISTICS – INVERTER PART ( $T_J$ as specified)

Symbol	Parameter	Conditions	Min.	Typ.	Max.	Unit
$V_{CE(SAT)}$	Collector – Emitter Saturation Voltage	$V_{DD} = V_{BS} = 15\text{ V}$ , $V_{IN} = 5\text{ V}$ , $I_C = 30\text{ A}$ , $T_J = 25^\circ\text{C}$	-	1.60	2.10	V
		$V_{DD} = V_{BS} = 15\text{ V}$ , $V_{IN} = 5\text{ V}$ , $I_C = 30\text{ A}$ , $T_J = 175^\circ\text{C}$		2.00	2.60	V
$V_F$	FWDi Forward Voltage	$V_{IN} = 0\text{ V}$ , $I_F = 30\text{ A}$ , $T_J = 25^\circ\text{C}$	-	2.00	2.60	V
		$V_{IN} = 0\text{ V}$ , $I_F = 30\text{ A}$ , $T_J = 175^\circ\text{C}$		1.95	2.55	V
HS	$t_{ON}$	High Side Switching Times $V_{PN} = 300\text{ V}$ , $V_{DD} = 15\text{ V}$ , $I_C = 30\text{ A}$ , $T_J = 25^\circ\text{C}$ $V_{IN} = 0\text{ V} \Leftrightarrow 5\text{ V}$ , Inductive Load See Figure 5 (Note 7)	0.50	0.90	1.40	$\mu\text{s}$
	$t_{C(ON)}$		-	0.20	0.60	$\mu\text{s}$
	$t_{OFF}$		-	0.85	1.35	$\mu\text{s}$
	$t_{C(OFF)}$		-	0.15	0.45	$\mu\text{s}$
	$t_{rr}$		-	0.08	-	$\mu\text{s}$
LS	$t_{ON}$	Low Side Switching Times $V_{PN} = 300\text{ V}$ , $V_{DD} = 15\text{ V}$ , $I_C = 30\text{ A}$ , $T_J = 25^\circ\text{C}$ $V_{IN} = 0\text{ V} \Leftrightarrow 5\text{ V}$ , Inductive Load See Figure 5 (Note 7)	0.40	0.80	1.30	$\mu\text{s}$
	$t_{C(ON)}$		-	0.25	0.60	$\mu\text{s}$
	$t_{OFF}$		-	0.90	1.40	$\mu\text{s}$
	$t_{C(OFF)}$		-	0.15	0.45	$\mu\text{s}$
	$t_{rr}$		-	0.10	-	$\mu\text{s}$
$I_{CES}$	Collector–Emitter Leakage Current	$T_J = 25^\circ\text{C}$ , $V_{CE} = V_{CES}$	-	-	3	mA

7.  $t_{ON}$  and  $t_{OFF}$  include the propagation delay time of the internal drive IC.  $t_{C(ON)}$  and  $t_{C(OFF)}$  are the switching time of IGBT itself under the given gate driving condition internally. For the detailed information see Figure 3.

## PACKAGE MARKING AND ORDERING INFORMATION

Part Number	Top Marking	Package	Shipping
NFVA33065L32	NFVA33065L32	ASPM27-CCA	10 Units/Tube

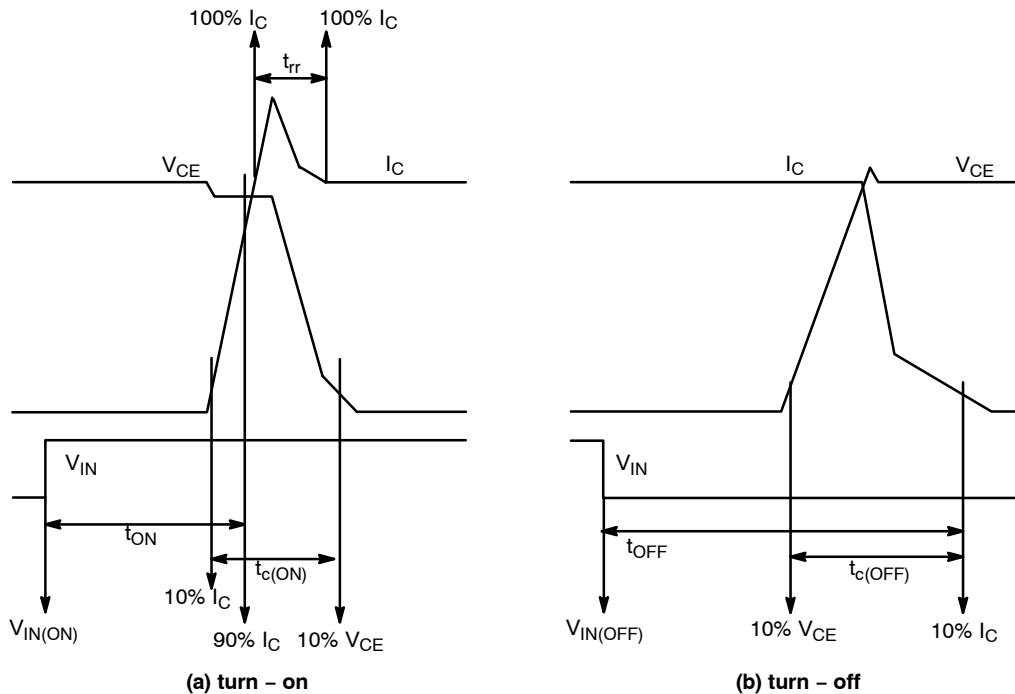

Figure 3. Switching Time Definition

# NFVA33065L32

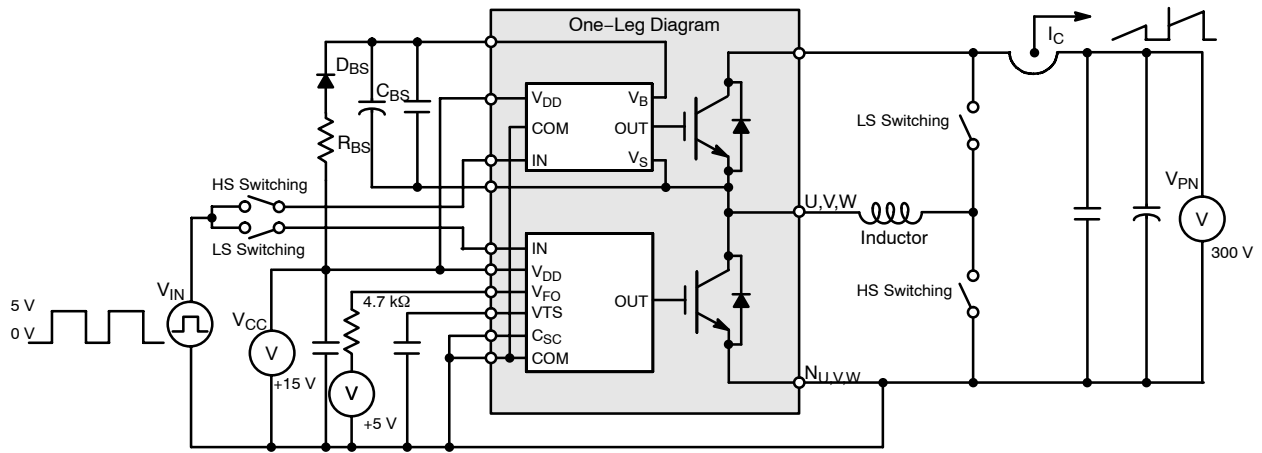

Figure 4. Example Circuit for Switching Test

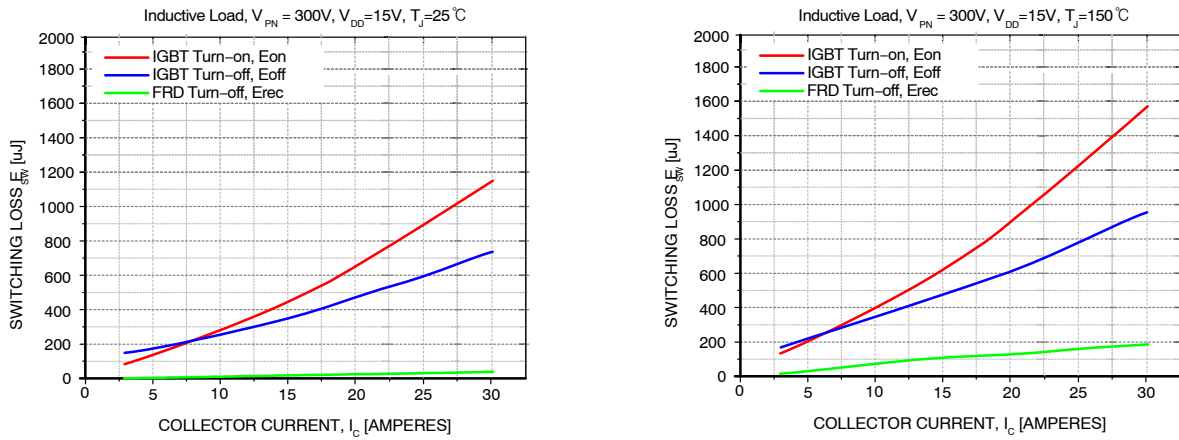

Figure 5. Switching Loss Characteristics

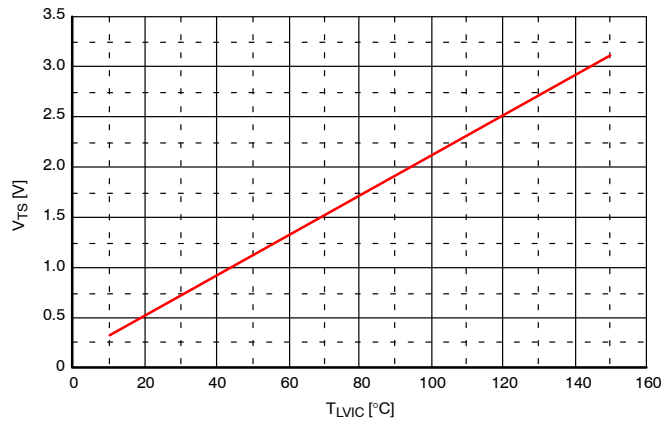

Figure 6. Temperature Profile of  $V_{TS}$  (Typical)

# NFVA33065L32

## CONTROL PART (T<sub>J</sub> = 25°C)

Symbol	Parameter	Conditions	Min.	Typ.	Max.	Unit	
I <sub>QDDH</sub>	Quiescent V <sub>DD</sub> Supply Current	V <sub>DD(H)</sub> = 15 V, I <sub>N(UH,VH,WH)</sub> = 0 V	V <sub>DD(H)</sub> - COM	-	-	0.40	mA
I <sub>QDDL</sub>		V <sub>DD(L)</sub> = 15 V, I <sub>N(UL,VL,WL)</sub> = 0 V	V <sub>DD(L)</sub> - COM	-	-	4.80	mA
I <sub>PDDH</sub>	Operating V <sub>DD</sub> Supply Current	V <sub>DD(H)</sub> = 15 V, f <sub>PWM</sub> = 20 kHz, duty = 50%, applied to one PWM signal input for High- Side	V <sub>DD(H)</sub> - COM	-	-	0.48	mA
I <sub>PDDL</sub>		V <sub>DD(L)</sub> = 15 V, f <sub>PWM</sub> = 20 kHz, duty = 50%, applied to one PWM signal input for Low- Side	V <sub>DD(L)</sub> - COM	-	-	8.80	mA
I <sub>QBS</sub>	Quiescent V <sub>BS</sub> Supply Current	V <sub>BS</sub> = 15 V, I <sub>N(UH,VH,WH)</sub> = 0 V	V <sub>B(U)</sub> - V <sub>S(U)</sub> , V <sub>B(V)</sub> - V <sub>S(V)</sub> , V <sub>B(W)</sub> - V <sub>S(W)</sub> ,	-	-	0.24	mA
I <sub>PBS</sub>	Operating V <sub>BS</sub> Supply Current	V <sub>DD</sub> = V <sub>BS</sub> = 15 V, f <sub>PWM</sub> = 20 kHz, duty = 50%, applied to one PWM signal input for High-Side	V <sub>B(U)</sub> - V <sub>S(U)</sub> , V <sub>B(V)</sub> - V <sub>S(V)</sub> , V <sub>B(W)</sub> - V <sub>S(W)</sub> ,	-	-	4.40	mA
V <sub>FOH</sub>	Fault Output Voltage	V <sub>DD</sub> = 15 V, V <sub>SC</sub> = 0 V, V <sub>FO</sub> Circuit: 4.7 kΩ to 5 V Pull-up	4.5	-	-	V	
V <sub>FOL</sub>		V <sub>DD</sub> = 15 V, V <sub>SC</sub> = 1 V, V <sub>FO</sub> Circuit: 4.7 kΩ to 5 V Pull-up	-	-	0.50	V	
V <sub>SC(ref)</sub>	Short Circuit Trip Level	V <sub>DD</sub> = 15 V (Note 8)	C <sub>SC</sub> - COM <sub>(L)</sub>	0.45	0.50	0.55	V
UV <sub>DDD</sub>	Supply Circuit Under-Voltage Protection	Detection Level	9.80	-	13.3	V	
UV <sub>DDR</sub>		Reset Level	10.3	-	13.8	V	
UV <sub>BSD</sub>		Detection Level	9.00	-	12.5	V	
UV <sub>BSR</sub>		Reset Level	9.50	-	13.0	V	
t <sub>FOD</sub>	Fault-Out Pulse Width		50	-	-	μs	
V <sub>TS</sub>	LVIC Temperature Sensing Voltage Output	V <sub>DD(L)</sub> = 15 V, T <sub>LVIC</sub> = 25°C (Note 9) See Figure 6	540	640	740	mV	
V <sub>IN(ON)</sub>	ON Threshold Voltage	Applied between I <sub>N(UH,VH,WH)</sub> - COM I <sub>N(UL,VL,WL)</sub> - COM	-	-	2.60	V	
V <sub>IN(OFF)</sub>	OFF Threshold Voltage		0.80	-	-	V	

8. Short-circuit current protection is functioning only at the low-sides.

9. T<sub>LVIC</sub> is the temperature of LVIC itself. V<sub>TS</sub> is only for sensing temperature of LVIC and can not shutdown IGBTs automatically.

## RECOMMENDED OPERATING CONDITIONS

Symbol	Parameter	Conditions	Value			Unit
			Min.	Typ.	Max.	
V <sub>PN</sub>	Supply Voltage	Applied between P - N <sub>U</sub> , N <sub>V</sub> , N <sub>W</sub>	-	300	400	V
V <sub>DD</sub>	Control Supply Voltage	Applied between V <sub>DD(H)</sub> - COM, V <sub>DD(L)</sub> - COM	14.0	15	16.5	V
V <sub>BS</sub>	High-Side Bias Voltage	Applied between V <sub>B(U)</sub> - V <sub>S(U)</sub> , V <sub>B(V)</sub> - V <sub>S(V)</sub> , V <sub>B(W)</sub> - V <sub>S(W)</sub>	13.0	15	18.5	V
dV <sub>DD</sub> /dt, dV <sub>BS</sub> /dt,	Control Supply Variation		-1	-	1	V/μs
t <sub>dead</sub>	Blanking Time for Preventing Arm-Short	For Each Input Signal	2.0	-	-	μs
f <sub>PWM</sub>	PWM Input Signal	-40°C ≤ T <sub>C</sub> ≤ 125°C, -40°C ≤ T <sub>J</sub> ≤ 150°C	-	-	20	kHz
V <sub>SEN</sub>	Voltage for Current Sensing	Applied between N <sub>U</sub> , N <sub>V</sub> , N <sub>W</sub> - COM (Including Surge Voltage)	-5	-	5	V



**RECOMMENDED OPERATING CONDITIONS** (continued)

PW <sub>IN(ON)</sub>	Minimum Input Pulse Width	V <sub>DD</sub> = V <sub>BS</sub> = 15 V, I <sub>C</sub> ≤ 30 A, Wiring Inductance between N <sub>U,V,W</sub> and DC Link N < 10 nH (Note 10)	1.5	-	-	μs
PW <sub>IN(OFF)</sub>			1.5	-	-	
PW <sub>IN(ON)</sub>		V <sub>DD</sub> = V <sub>BS</sub> = 15 V, 30 A ≤ I <sub>C</sub> ≤ 60 A, Wiring Inductance between N <sub>U,V,W</sub> and DC Link N < 10 nH (Note 10)	2.0	-	-	μs
PW <sub>IN(OFF)</sub>			2.0	-	-	
T <sub>J</sub>	Junction Temperature		-40	-	150	°C

10. This product might not make response if input pulse width is less than the recommended value.

**MECHANICAL CHARACTERISTICS AND RATINGS**

Parameter	Conditions	Value			Unit	
		Min.	Typ.	Max.		
Device Flatness	See Figure 7	0	-	+150	μm	
Mounting Torque	Mounting Screw: M3 See Figure 8	Recommended 0.7 N•m	0.6	0.7	0.8	N•m
		Recommended 7.1 kg•cm	6.2	7.1	8.1	kg•cm
Terminal Pulling Strength	Load 19.8 N	10	-	-	s	
Terminal Bending Strength	Load 9.8 N 90 deg. bend	2	-	-	times	
Weight		-	15	-	g	

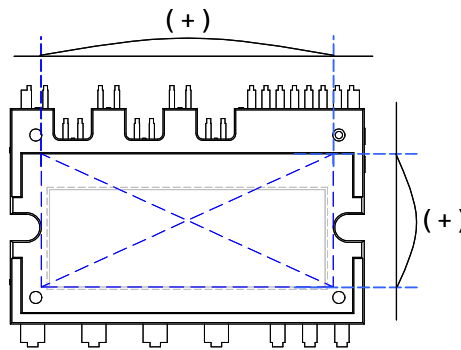

**Figure 7. Flatness Measurement Position**

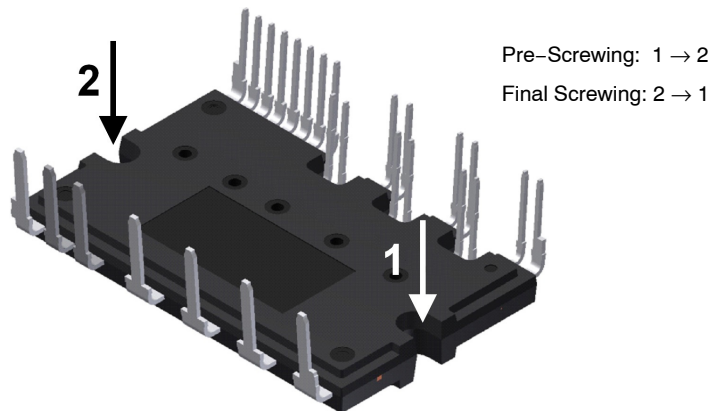

**NOTES:**

- 11. Do not make over torque when mounting screws. Much mounting torque may cause DBC cracks, as well as bolts and Al heat-sink destruction
- 12. Avoid one-sided tightening stress. Figure 8 shows the recommended torque order for mounting screws. Uneven mounting can cause the DBC substrate of package to be damaged. The pre-screwing torque is set to 20 ~ 30% of maximum torque rating.

**Figure 8. Mounting Screws Torque Order**

## NFVA33065L32

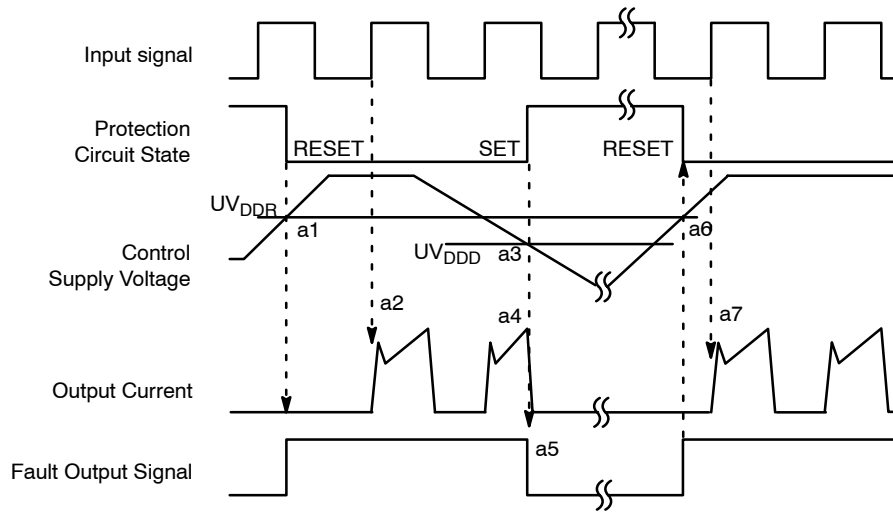

- a1: Control supply voltage rises: After the voltage rises  $UV_{DDR}$ , the circuits start to operate when next input is applied.
- a2: Normal operation: IGBT ON and carrying current.
- a3: Under voltage detection ( $UV_{DDD}$ ).
- a4: IGBT OFF in spite of control input condition.
- a5: Fault output operation starts with a fixed pulse width.
- a6: Under voltage reset ( $UV_{DDR}$ ).
- a7: Normal operation: IGBT ON and carrying current by triggering next signal from LOW to HIGH.

**Figure 9. Under-Voltage Protection (Low-Side)**

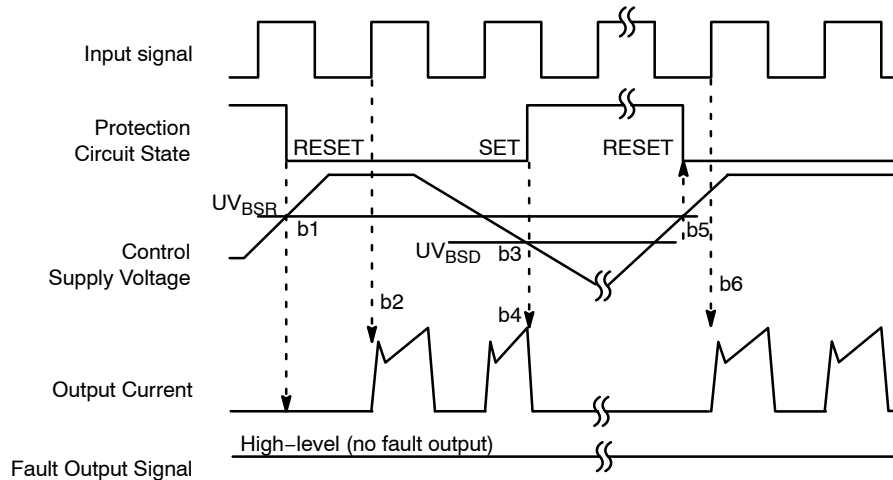

- b1: Control supply voltage rises: After the voltage rises  $UV_{BSR}$ , the circuits start to operate when next input is applied.
- b2: Normal operation: IGBT ON and carrying current.
- b3: Under voltage detection ( $UV_{BSD}$ ).
- b4: IGBT OFF in spite of control input condition, but there is no fault output signal.
- b5: Under voltage reset ( $UV_{BSR}$ ).
- b6: Normal operation: IGBT ON and carrying current by triggering next signal from LOW to HIGH.

**Figure 10. Under-Voltage Protection (High-Side)**

## NFVA33065L32

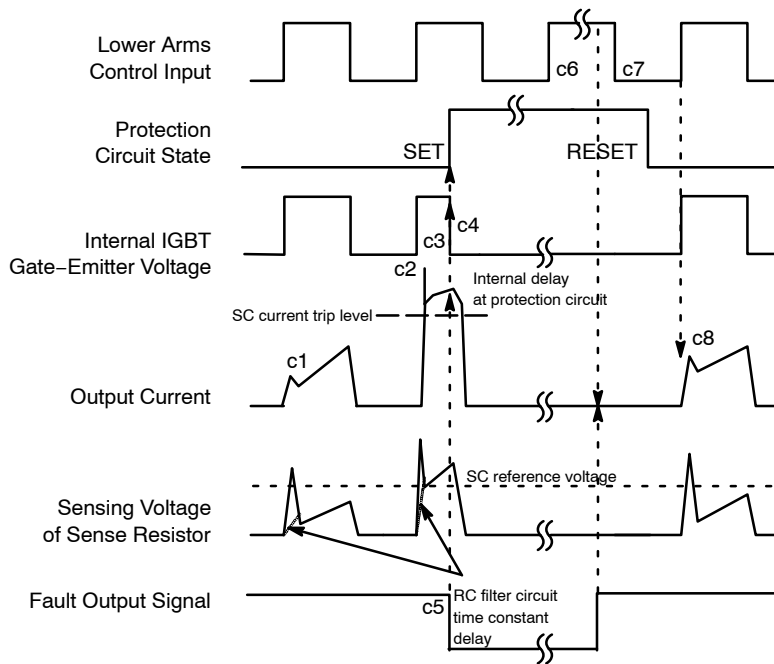

(with the external sense resistance and RC filter connection)

- c1: Normal operation: IGBT ON and carrying current.
- c2: Short circuit current detection (SC trigger).
- c3: All low-side IGBT's gate are hard interrupted.
- c4: All low-side IGBTs turn OFF.
- c5: Fault output operation starts with a fixed pulse width.
- c6: Input HIGH: IGBT ON state, but during the active period of fault output the IGBT doesn't turn ON.
- c7: Fault output operation finishes, but IGBT doesn't turn on until triggering next signal from LOW to HIGH.
- c8: Normal operation: IGBT ON and carrying current.

**Figure 11. Short-Circuit Current Protection (Low-Side Operation Only)**

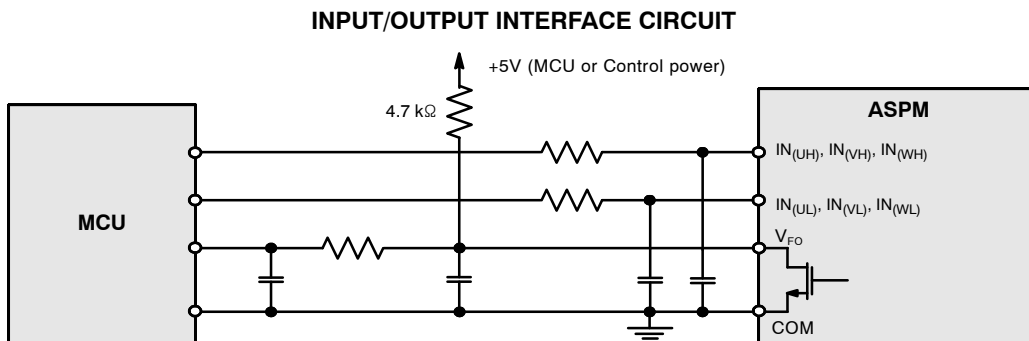

NOTE:

13. RC coupling at each input might change depending on the PWM control scheme used in the application and the wiring impedance of the application's printed circuit board. The input signal section of the ASPM27 product integrates 5kΩ (typ.) pull-down resistor. Therefore, when using an external filtering resistor, please pay attention to the signal voltage drop at input terminal.

**Figure 12. Recommended CPU I/O Interface Circuit**

# NFVA33065L32

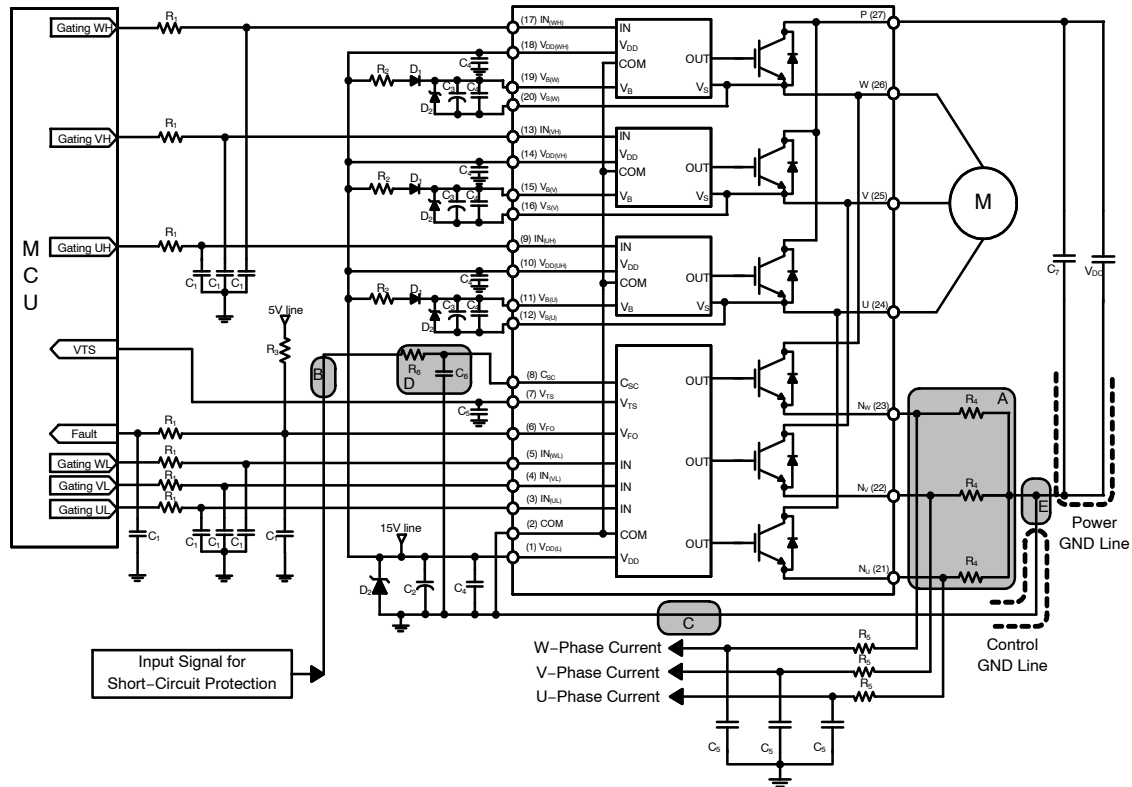

## NOTES:

14. To avoid malfunction, the wiring of each input should be as short as possible. (less than 2–3 cm)
15.  $V_{FO}$  output is open–drain type. The signal line should be pulled up to the positive side of the MCU or control power supply with a resistor that makes  $I_{FO}$  up to 2mA. Refer to Figure 12.
16. Input signal is active–HIGH type. There is a 5 k $\Omega$  resistor inside the IC to pull–down each input signal line to GND. RC coupling circuits should be adopted for the prevention of input signal oscillation.  $R_1C_1$  time constant should be selected in the range 50–150 ns. (Recommended  $R_1 = 100 \Omega$ ,  $C_1 = 1 \text{ nF}$ )
17. Each wiring pattern inductance of A point should be minimized (Recommended less than 10 nH). Use the shunt resistor  $R_4$  of surface mounted (SMD) type to reduce wiring inductance. To prevent malfunction, wiring of point E should be connected to the terminal of the shunt resistor  $R_4$  as close as possible.
18. To prevent errors of the protection function, the wiring of B, C and D point should be as short as possible.
19. In the short–circuit protection circuit, please select the  $R_6C_6$  time constant in the range 1.5–2  $\mu\text{s}$ .
20. Each capacitor should be mounted as close to the pins of the ASPM27 product as possible.
21. To prevent surge destruction, the wiring between the smoothing capacitor  $C_7$  and the P & GND pins should be as short as possible. The use of a high–frequency non–inductive capacitor between the P & GND pins is recommended.
22. Relays are used at almost every systems of electrical equipment at industrial application. In these cases, there should be sufficient distance between the CPU and the relays.
23. The zener diode or transient voltage suppressor should be adopted for the protection of ICs from the surge destruction between each pair of control supply terminals (Recommended zener diode is 22 V/1 W, which has the lower zener impedance characteristic than about 15  $\Omega$ ).
24.  $C_2$  of around 7 times larger than bootstrap capacitor  $C_3$  is recommended.
25. Choose the electrolytic capacitor with good temperature characteristic in  $C_3$ . Also choose 0.1–0.2  $\mu\text{F}$  R–category ceramic capacitors with good temperature and frequency characteristics in  $C_4$ .

**Figure 13. Typical Application Circuit**

SPM is registered trademarks of Semiconductor Components Industries, LLC (SCILLC) or its subsidiaries in the United States and/or other countries.

# MECHANICAL CASE OUTLINE PACKAGE DIMENSIONS

ON Semiconductor®



## SPMCA-027 / PDD STD, SPM27-CA, DBC TYPE CASE MODFJ ISSUE O

DATE 31 JAN 2017

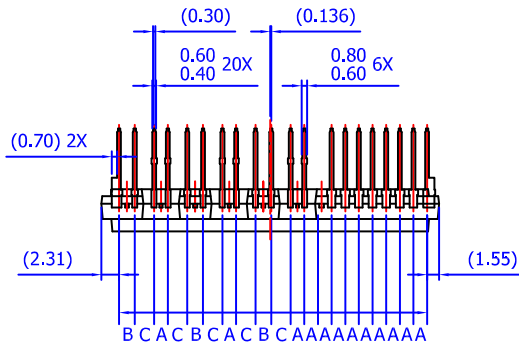

LEAD PITCH (TOLERANCE : ±0.30)

- A : 1.778
- B : 2.050
- C : 2.531

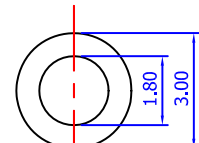
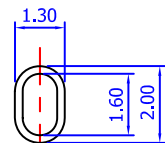
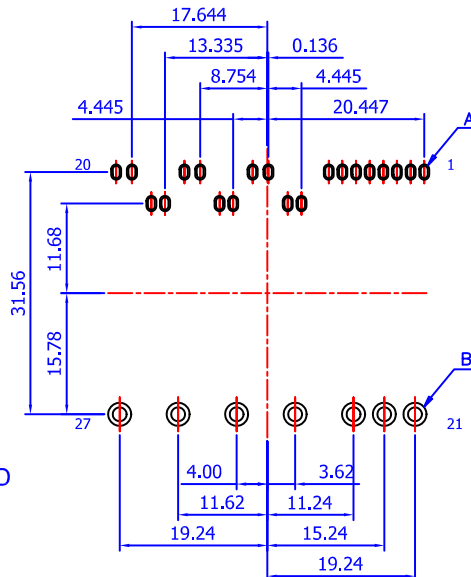
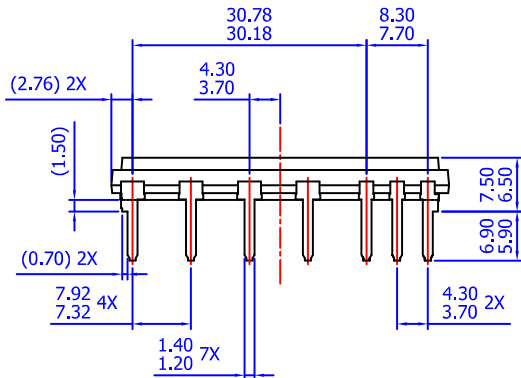
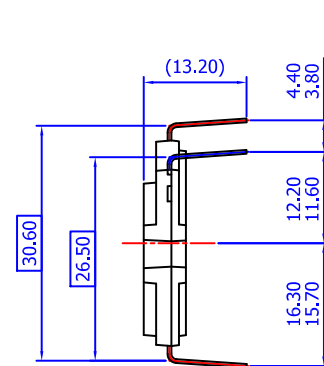
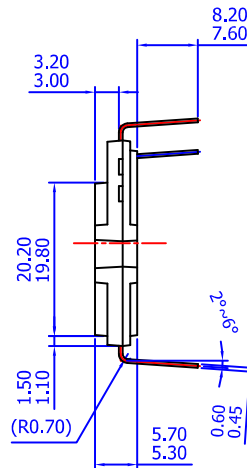
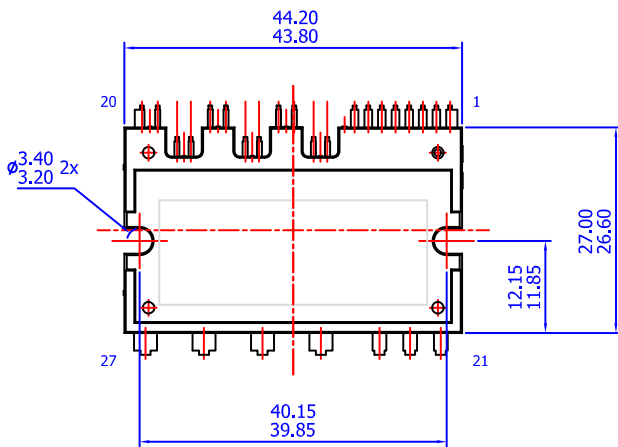

- NOTES: UNLESS OTHERWISE SPECIFIED
- A) THIS PACKAGE DOES NOT COMPLY TO ANY CURRENT PACKAGING STANDARD
  - B) ALL DIMENSIONS ARE IN MILLIMETERS
  - C) DIMENSIONS ARE EXCLUSIVE OF BURRS, MOLD FLASH, AND TIE BAR EXTRUSIONS
  - D) ( ) IS REFERENCE

### LAND PATTERN RECOMMENDATIONS

<b>DOCUMENT NUMBER:</b>	<b>98AON13563G</b>	Electronic versions are uncontrolled except when accessed directly from the Document Repository. Printed versions are uncontrolled except when stamped "CONTROLLED COPY" in red.
<b>DESCRIPTION:</b>	<b>SPMCA-027 / PDD STD, SPM27-CA, DBC TYPE</b>	<b>PAGE 1 OF 1</b>

ON Semiconductor and ON are trademarks of Semiconductor Components Industries, LLC dba ON Semiconductor or its subsidiaries in the United States and/or other countries. ON Semiconductor reserves the right to make changes without further notice to any products herein. ON Semiconductor makes no warranty, representation or guarantee regarding the suitability of its products for any particular purpose, nor does ON Semiconductor assume any liability arising out of the application or use of any product or circuit, and specifically disclaims any and all liability, including without limitation special, consequential or incidental damages. ON Semiconductor does not convey any license under its patent rights nor the rights of others.

ON Semiconductor and  are trademarks of Semiconductor Components Industries, LLC dba ON Semiconductor or its subsidiaries in the United States and/or other countries. ON Semiconductor owns the rights to a number of patents, trademarks, copyrights, trade secrets, and other intellectual property. A listing of ON Semiconductor's product/patent coverage may be accessed at [www.onsemi.com/site/pdf/Patent-Marking.pdf](http://www.onsemi.com/site/pdf/Patent-Marking.pdf). ON Semiconductor reserves the right to make changes without further notice to any products herein. ON Semiconductor makes no warranty, representation or guarantee regarding the suitability of its products for any particular purpose, nor does ON Semiconductor assume any liability arising out of the application or use of any product or circuit, and specifically disclaims any and all liability, including without limitation special, consequential or incidental damages. Buyer is responsible for its products and applications using ON Semiconductor products, including compliance with all laws, regulations and safety requirements or standards, regardless of any support or applications information provided by ON Semiconductor. "Typical" parameters which may be provided in ON Semiconductor data sheets and/or specifications can and do vary in different applications and actual performance may vary over time. All operating parameters, including "Typicals" must be validated for each customer application by customer's technical experts. ON Semiconductor does not convey any license under its patent rights nor the rights of others. ON Semiconductor products are not designed, intended, or authorized for use as a critical component in life support systems or any FDA Class 3 medical devices or medical devices with a same or similar classification in a foreign jurisdiction or any devices intended for implantation in the human body. Should Buyer purchase or use ON Semiconductor products for any such unintended or unauthorized application, Buyer shall indemnify and hold ON Semiconductor and its officers, employees, subsidiaries, affiliates, and distributors harmless against all claims, costs, damages, and expenses, and reasonable attorney fees arising out of, directly or indirectly, any claim of personal injury or death associated with such unintended or unauthorized use, even if such claim alleges that ON Semiconductor was negligent regarding the design or manufacture of the part. ON Semiconductor is an Equal Opportunity/Affirmative Action Employer. This literature is subject to all applicable copyright laws and is not for resale in any manner.

## PUBLICATION ORDERING INFORMATION

### LITERATURE FULFILLMENT:

Email Requests to: [orderlit@onsemi.com](mailto:orderlit@onsemi.com)

ON Semiconductor Website: [www.onsemi.com](http://www.onsemi.com)

### TECHNICAL SUPPORT

North American Technical Support:  
Voice Mail: 1 800-282-9855 Toll Free USA/Canada  
Phone: 011 421 33 790 2910

Europe, Middle East and Africa Technical Support:

Phone: 00421 33 790 2910

For additional information, please contact your local Sales Representative