

DESCRIPTION

The MC33164 and the MC34164 are micropower undervoltage sensing circuits ideal for use in low-power battery applications, computer peripheral, consumer, appliance and automotive equipment. The device offers a 1.2V temperature compensated bandgap reference, a precision comparator with hysteresis and a high current open collector

output. This device operates from 1 to 10V input supply and drains $<10\mu\text{A}$ in a faultless condition and a trip level of 4.33V. Both devices are available in an 8-pin, 150mil SOIC package and a plastic TO-92 package. The MC33164 is rated from -40°C to 85°C and the MC34164 from 0°C to 70°C .

IMPORTANT: For the most current data, consult MICROSEMI's website: <http://www.microsemi.com>

KEY FEATURES

- LOW STANDBY CURRENT
- TEMPERATURE COMPENSATED BANDGAP REFERENCE
- PRECISION COMPARATOR WITH 50MV OF HYSTERESIS
- CLAMP DIODE FOR DISCHARGING DELAY CAPACITOR
- OUTPUT CURRENT SINK CAPABILITY FROM 7 TO 50MA
- 1-10V INPUT SUPPLY RANGE
- AVAILABLE IN 150MIL, 8-PIN SOIC AND PLASTIC TO-92 PACKAGES
- PIN-FOR-PIN COMPATIBLE WITH MC33164 / 34164

PRODUCT HIGHLIGHT

LOW-VOLTAGE MICROPROCESSOR RESET

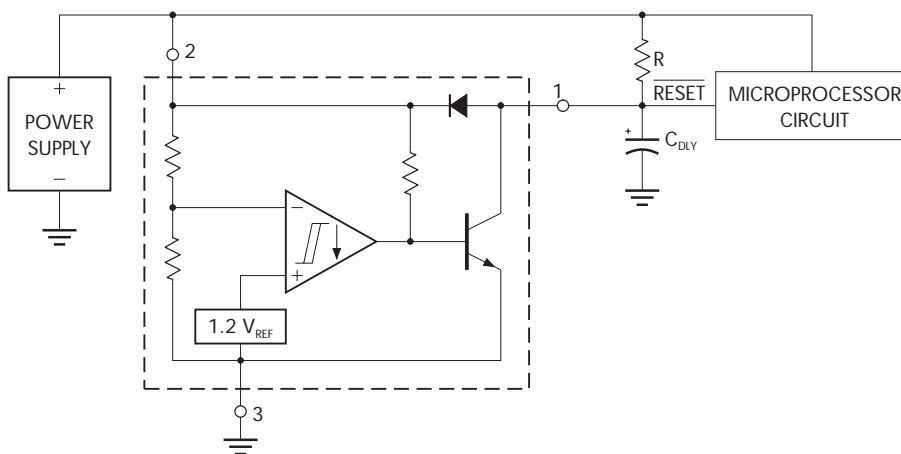

APPLICATIONS

- μPOWER RESET GENERATOR
- 5V VOLTAGE MONITOR
- BATTERY-LEVEL DETECTOR

PACKAGE ORDER INFO

T_A ($^{\circ}\text{C}$)	DM Plastic SOIC 8-Pin	LP Plastic TO-92 3-Pin
	RoHS Compliant / Pb-free Transition DC: 0440	RoHS Compliant / Pb-free Transition DC: 0509
0 to 70	MC34164DM	MC34164LP
-40 to 85	MC33164DM	MC33164LP

Note: Available in Tape & Reel. Append the letters "TR" to the part number. (i.e. MC33164DM-TR)

MC33164/MC34164

5V UNDERVOLTAGE SENSING CIRCUIT PRODUCTION DATA SHEET

ABSOLUTE MAXIMUM RATINGS (Note 1)

Input Supply Voltage (V_{IN})	-1V to 12V
RESET Output Voltage (V_{OUT})	-1V to 12V
Clamp Diode Forward Current	100mA
Operating Junction Temperature	
Plastic (DM - Package)	150°C
Storage Temperature Range	-65°C to 150°C
Lead Temperature (Soldering, 10 seconds)	300°C
Peak Package Solder Reflow Temp.(40 second max. exposure)	260°C (+0, -5)

Note 1. Values beyond which damage may occur. All voltages are specified with respect to ground, and all currents are positive into the specified terminal.

THERMAL DATA

DM PACKAGE:

THERMAL RESISTANCE-JUNCTION TO AMBIENT, θ_{JA}	165°C/W
---	---------

LP PACKAGE:

THERMAL RESISTANCE-JUNCTION TO AMBIENT, θ_{JA}	156°C/W
---	---------

Junction Temperature Calculation: $T_J = T_A + (P_D \times \theta_{JA})$.

The θ_{JA} numbers are guidelines for the thermal performance of the device/pc-board system. All of the above assume no ambient airflow.

PACKAGE PIN OUTS

RESET	1	8	N.C.
INPUT	2	7	N.C.
N.C.	3	6	N.C.
GROUND	4	5	N.C.

DM PACKAGE (Top View)

RoHS / Pb-free 100% Matte Tin Lead Finish

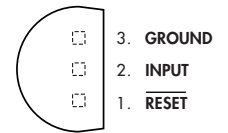

LP PACKAGE (Top View)

BLOCK DIAGRAM

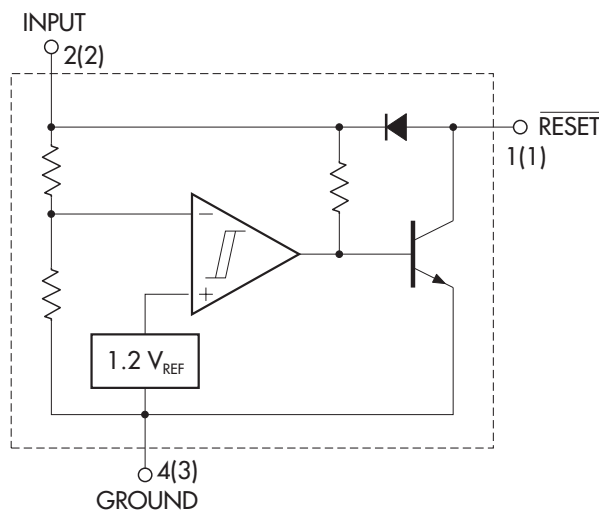

5V UNDERVOLTAGE SENSING CIRCUIT

PRODUCTION DATA SHEET

RECOMMENDED OPERATING CONDITIONS (Note 2)

Parameter	Symbol	Recommended Operating Conditions			Units
		Min.	Typ.	Max.	
Input Supply Voltage		1		10	V
RESET Output Voltage				10	V
Clamp Diode Forward Current				50	mA
Operating Ambient Temperature Range:					
MC34164	T_A	0		70	°C
MC33164	T_A	-40		85	°C

Note 2. Range over which the device is guaranteed functional.

ELECTRICAL CHARACTERISTICS

(Unless otherwise specified, these specifications apply over the operating ambient temperatures of $0^\circ\text{C} \leq T_A \leq 70^\circ\text{C}$ for the MC34164 and $-40^\circ\text{C} \leq T_A \leq 85^\circ\text{C}$ for the MC33164. Low duty cycle pulse testing techniques are used which maintains junction and case temperatures equal to the ambient temperature.)

Parameter	Symbol	Test Conditions	MC33164 / MC34164			Units
			Min.	Typ.	Max.	
Total Device						
Operating Input Voltage Range	V_{IN}		1.0		10	V
Quiescent Input Current	I_{IN}	$V_{IN} = 5.0\text{V}$		10	20	μA
		$V_{IN} = 10\text{V}$		19	50	μA
Comparator Section						
Threshold Voltage						
High-State Output	V_{IH}	V_{IN} Increasing	4.15	4.33	4.45	V
Low-State Output	V_{IL}	V_{IN} Decreasing	4.15	4.27	4.45	V
Hysteresis	V_H		0.02	0.06		V
RESET Output Section						
Output Sink Saturation	V_{OL}	$V_{IN} = 4.0\text{V}, I_{SINK} = 1.0\text{mA}$		0.05	0.40	V
		$V_{IN} = 1.0\text{V}, I_{SINK} = 0.25\text{mA}$		0.06	0.30	V
Output Sink Current	I_{SINK}	$V_{IN}, \overline{\text{RESET}} = 4.0\text{V}$	7.0		50	mA
Output Off-State Leakage		$V_{IN}, \overline{\text{RESET}} = 5.0\text{V}$			0.5	μA
		$V_{IN}, \overline{\text{RESET}} = 10\text{V}$			2.0	μA
Clamp Diode Forward Voltage	V_F	Pin 1 to pin 2, ($I_F = 5.0\text{mA}$)	0.6		1.2	V

MC33164/MC34164

5V UNDERVOLTAGE SENSING CIRCUIT

PRODUCTION DATA SHEET

GRAPH / CURVE INDEX

Characteristic Curves

FIGURE

1. COMPARATOR THRESHOLD VOLTAGE vs. TEMPERATURE
2. $\overline{\text{RESET}}$ OUTPUT VOLTAGE vs. INPUT VOLTAGE
3. $\overline{\text{RESET}}$ OUTPUT SATURATION vs. SINK CURRENT
4. INPUT CURRENT vs. INPUT VOLTAGE
5. $\overline{\text{RESET}}$ DELAY TIME (LOW to HIGH)
6. $\overline{\text{RESET}}$ DELAY TIME (HIGH to LOW)

FIGURE INDEX

Application Circuits

FIGURE

7. SWITCHING THE LOAD OFF WHEN BATTERY REACHES BELOW 4.3V
8. LOW VOLTAGE MICROPROCESSOR RESET
9. VOLTAGE MONITOR
10. MOSFET LOW VOLTAGE GATE DRIVE PROTECTION

5V UNDERVOLTAGE SENSING CIRCUIT
PRODUCTION DATA SHEET

CHARACTERISTIC CURVES

FIGURE 1. — COMPARATOR THRESHOLD VOLTAGE vs. TEMPERATURE

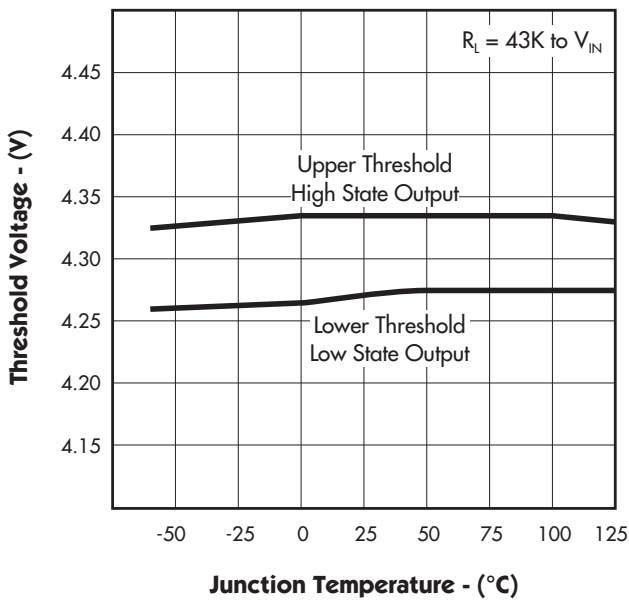

FIGURE 2. — \overline{RESET} OUTPUT VOLTAGE vs. INPUT VOLTAGE

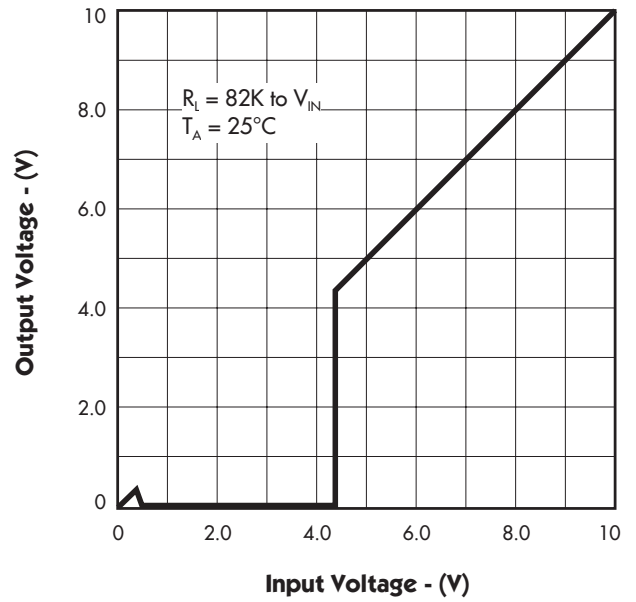

FIGURE 3. — \overline{RESET} OUTPUT SATURATION vs. SINK CURRENT

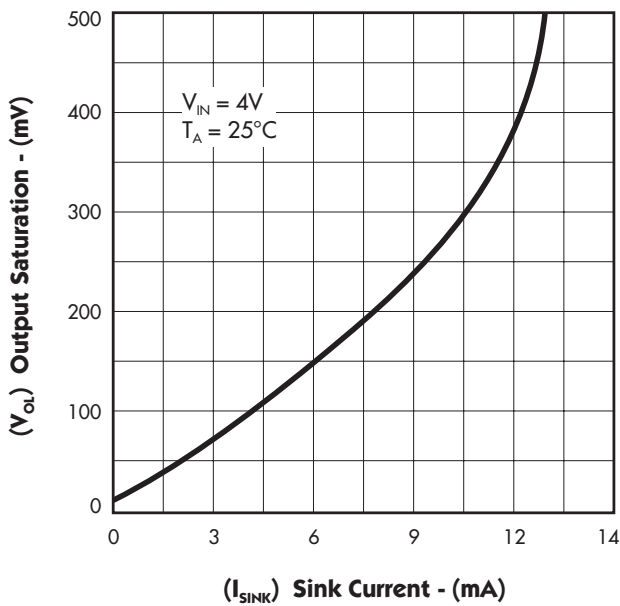
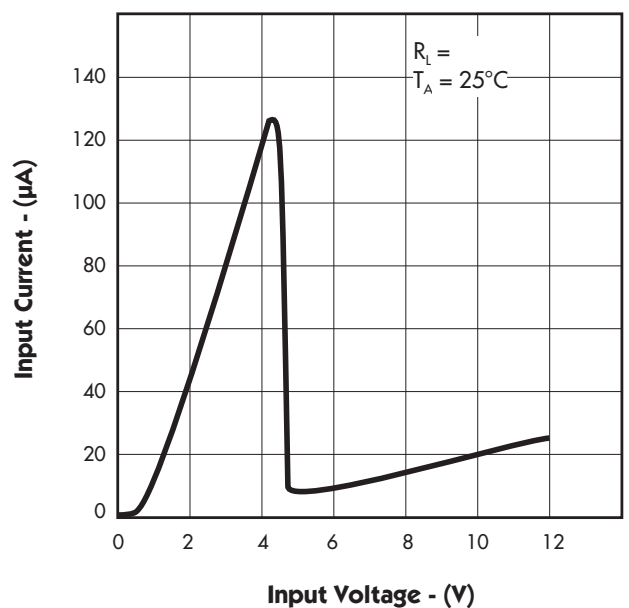

FIGURE 4. — INPUT CURRENT vs. INPUT VOLTAGE



MC33164/MC34164

5V UNDERVOLTAGE SENSING CIRCUIT PRODUCTION DATA SHEET

CHARACTERISTIC CURVES

FIGURE 5. — $\overline{\text{RESET}}$ DELAY TIME (LOW TO HIGH)

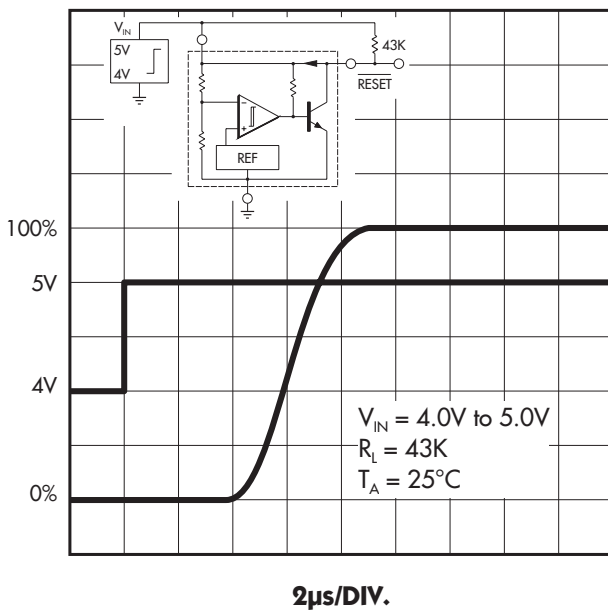
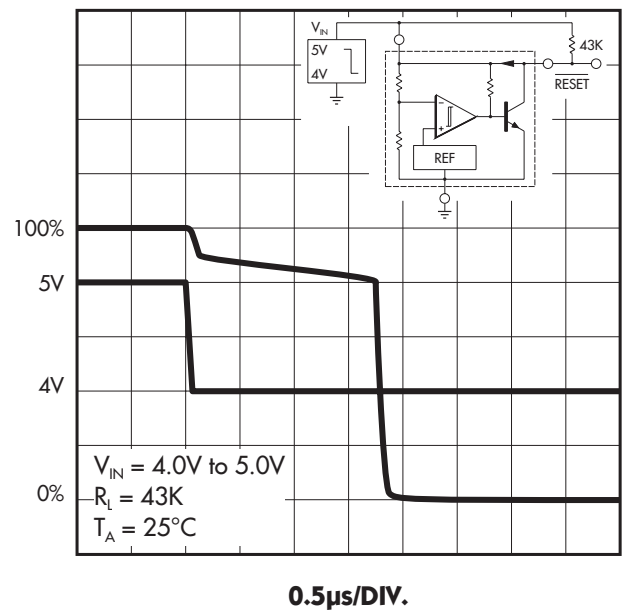

FIGURE 6. — $\overline{\text{RESET}}$ DELAY TIME (HIGH TO LOW)



5V UNDERVOLTAGE SENSING CIRCUIT PRODUCTION DATA SHEET

TYPICAL APPLICATION CIRCUITS

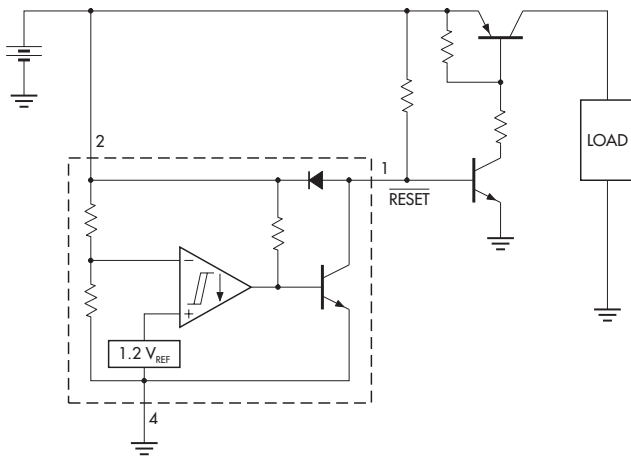
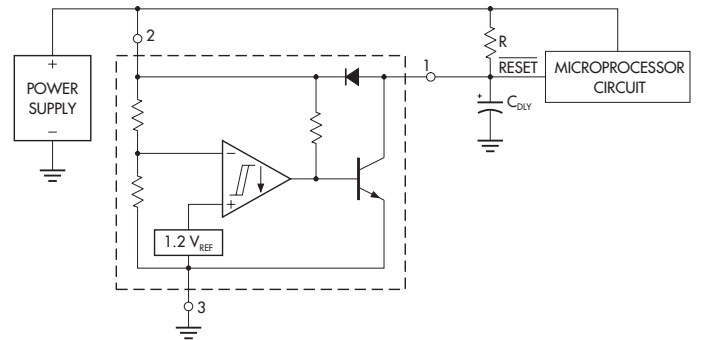

FIGURE 7. — SWITCHING THE LOAD OFF WHEN BATTERY VOLTAGE REACHES BELOW 4.3V



A time delayed reset can be accomplished with the addition of C_{DLY} . For systems with extremely fast power supply rise times ($< 500\text{ns}$) it is recommended that the RC_{DLY} time constant be greater than $5.0\mu\text{s}$. $V_{TH(MPU)}$ is the microprocessor reset input threshold.

$$t_{DLY} = R C_{DLY} \ln \left[\frac{1}{1 - \frac{V_{TH(MPU)}}{V_{IN}}} \right]$$

FIGURE 8. — LOW-VOLTAGE MICROPROCESSOR RESET

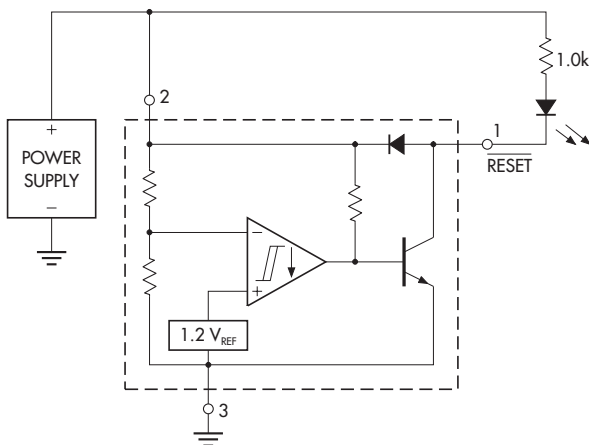
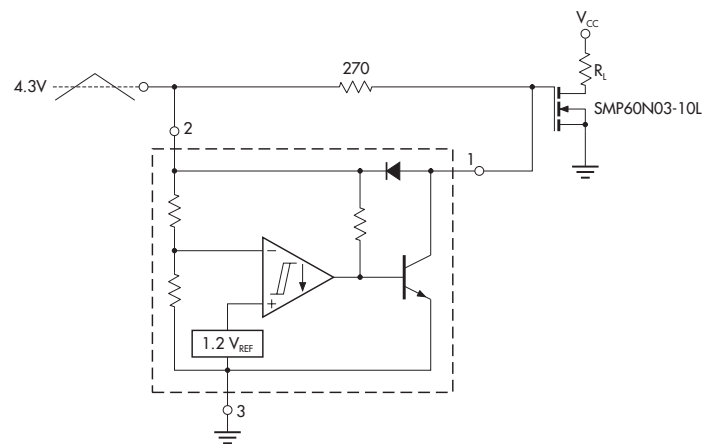

FIGURE 9. — VOLTAGE MONITOR



Overheating of the logic level power MOSFET due to insufficient gate voltage can be prevented with the above circuit. When the input signal is below the 4.3 volt threshold of the MC34164, its output grounds the gate of the L^2 MOSFET.

FIGURE 10. — MOSFET LOW-VOLTAGE GATE DRIVE PROTECTION