

Silicon Power Rectifier S/R20 Series

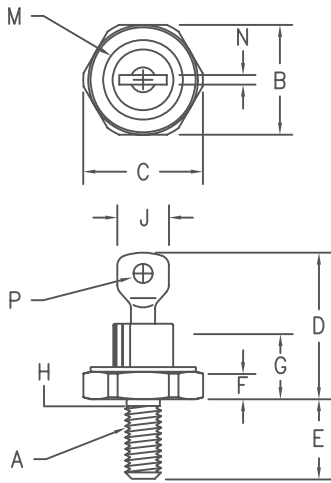

Notes:

- 10-32 UNF3A
- Full threads within 2 1/2 threads
- Standard Polarity: Stud is Cathode
Reverse Polarity: Stud is Anode

Dim.	Inches		Millimeter		Notes
	Minimum	Maximum	Minimum	Maximum	
A	---	---	---	---	1
B	.424	.437	10.77	11.10	
C	---	.505	---	12.82	
D	.600	.800	15.24	20.32	
E	.422	.453	10.72	11.50	
F	.075	.175	1.91	4.44	
G	---	.405	---	10.29	
H	.163	.189	4.15	4.80	2
J	---	.310	---	7.87	
M	---	.350	---	8.89	Dia
N	.020	.065	.510	1.65	
P	.070	.100	1.78	2.54	Dia

D0203AA (D04)

Microsemi Catalog Number	JEDEC Numbers	Peak Reverse Voltage
1N1064	1N1341, A,B,C	1N1581 1N1612,A 1N2228,A 1N2491 50V
1N1065	1N1342, A,B,C	1N1582 1N1613,A 1N2492 100V
1N1066	1N1343, A,B,C	150V
*S2020	1N1067 1N1344, A,B,C	1N1583 1N1614,A 1N2230,A 1N2493 200V
1N1068	1N1345, A,B,C	1N1584 1N2232,A 1N2494 300V
*S2040	1N1069 1N1346, A,B,C	1N1585 1N1615,A 1N2234,A 1N2495 400V
*S2060	1N1347, A,B,C	1N1586 1N2236,A 1N2496 500V
*S2080	1N1348, A,B,C	1N1587 1N1616,A 1N2238,A 1N2497 600V
*S20100		1N4458 1N2240,A 800V
*S20120		1N4459 1N2242,A 1000V
		1N2244,A 1200V

*Change S to R in part number for Reverse Polarity
For 1N types add an R suffix for Reverse Polarity

- Glass Passivated Die
- Low Forward Voltage
- 200A Surge Rating
- Glass to metal seal construction
- V_{RRM} to 1200V
- Low cost Non-RoHS package

Electrical Characteristics

Average forward current	$I_F(AV)$ 16 Amps	$T_C = 153^\circ C$, half sine wave, $R_{\theta JC} = 2.5^\circ C/W$
Maximum surge current	I_{FSM} 200 Amps	8.3ms, half sine, $T_J = 200^\circ C$
Max $I^2 t$ for fusing	$I^2 t$ 165 $A^2 s$	
Max peak forward voltage	V_{FM} 1.3 Volts	$I_{FM} = 30A; T_J = 25^\circ C^*$
Max peak reverse current	I_{RM} 10 μA	$V_{RRM, T_J} = 25^\circ C$
Max peak reverse current	I_{RM} 1.0 mA	$V_{RRM, T_J} = 150^\circ C$
Max Recommended Operating Frequency	10kHz	

*Pulse test: Pulse width 300 μsec . Duty cycle 2%

Thermal and Mechanical Characteristics

Storage temperature range	T_{STG}	$-65^\circ C$ to $200^\circ C$
Operating junction temp range	T_J	$-65^\circ C$ to $200^\circ C$
Maximum thermal resistance	$R_{\theta JC}$	$2.5^\circ C/W$ Junction to Case
Mounting torque		25-30 inch pounds
Weight		.16 ounces (5.0 grams) typical

S/R20

Figure 1
Typical Forward Characteristics

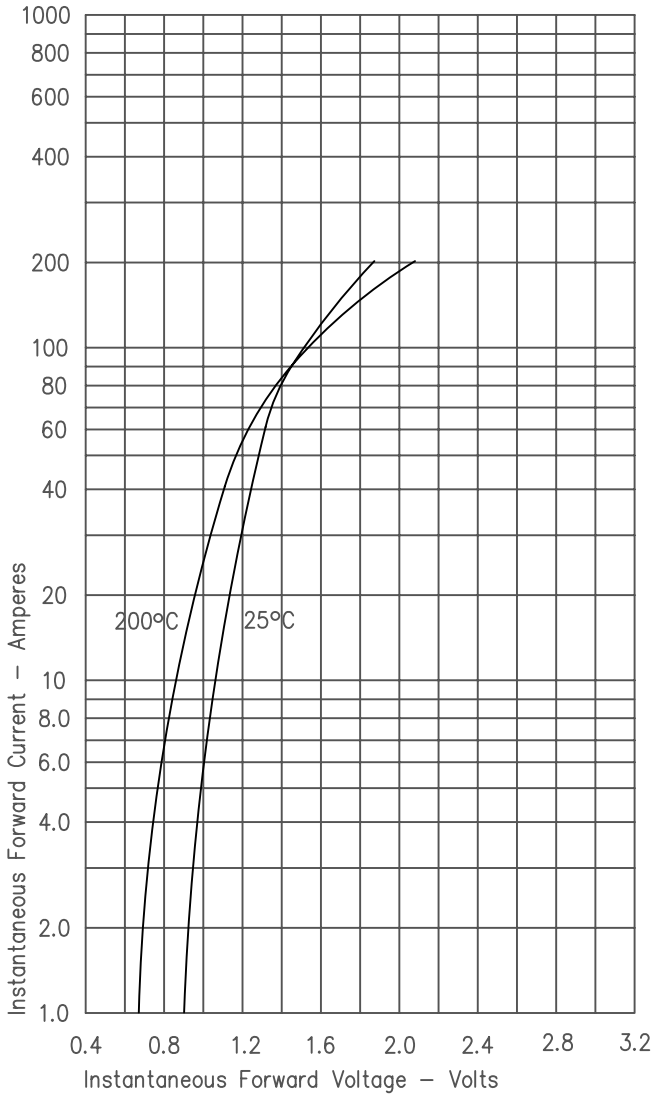

Figure 3
Forward Current Derating

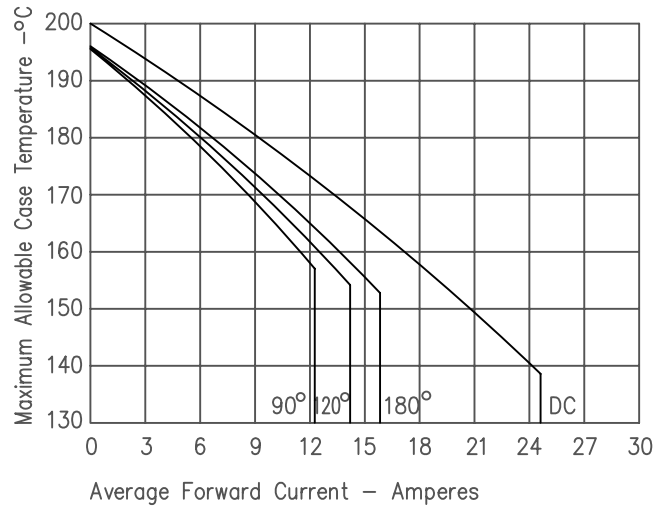

Figure 4
Maximum Forward Power Dissipation

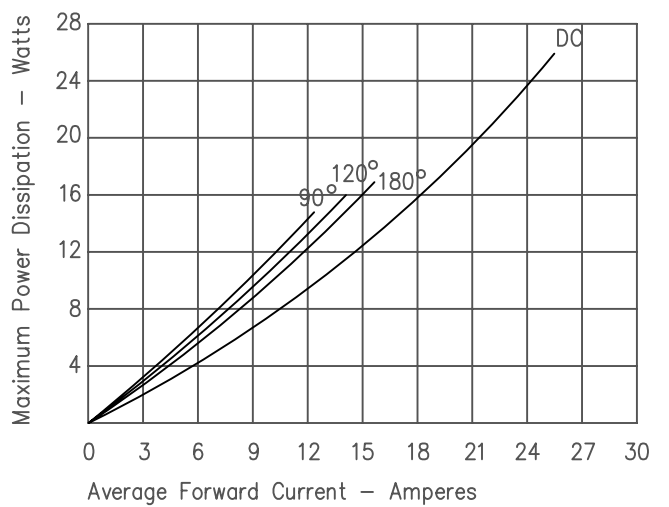

Figure 2
Typical Reverse Characteristics

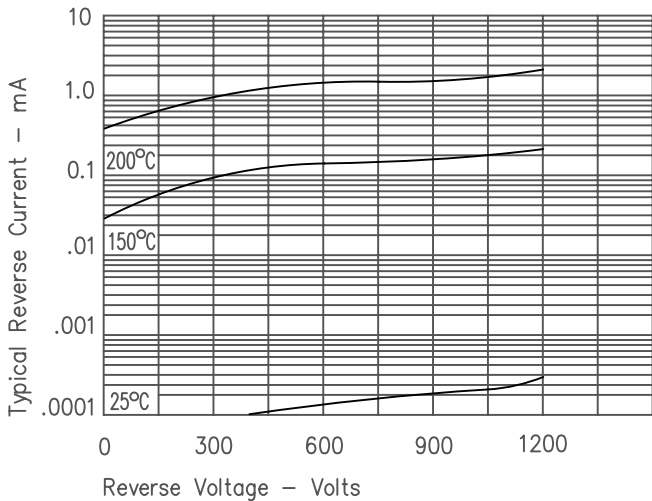

Figure 5
Transient Thermal Impedance

