

Jun.1.2020 Copyright 2020 HIROSE ELECTRIC CO., LTD. All Rights Reserved.
In case of consideration for using Automotive equipment / device which demand high reliability, kindly contact our sales window correspondents.

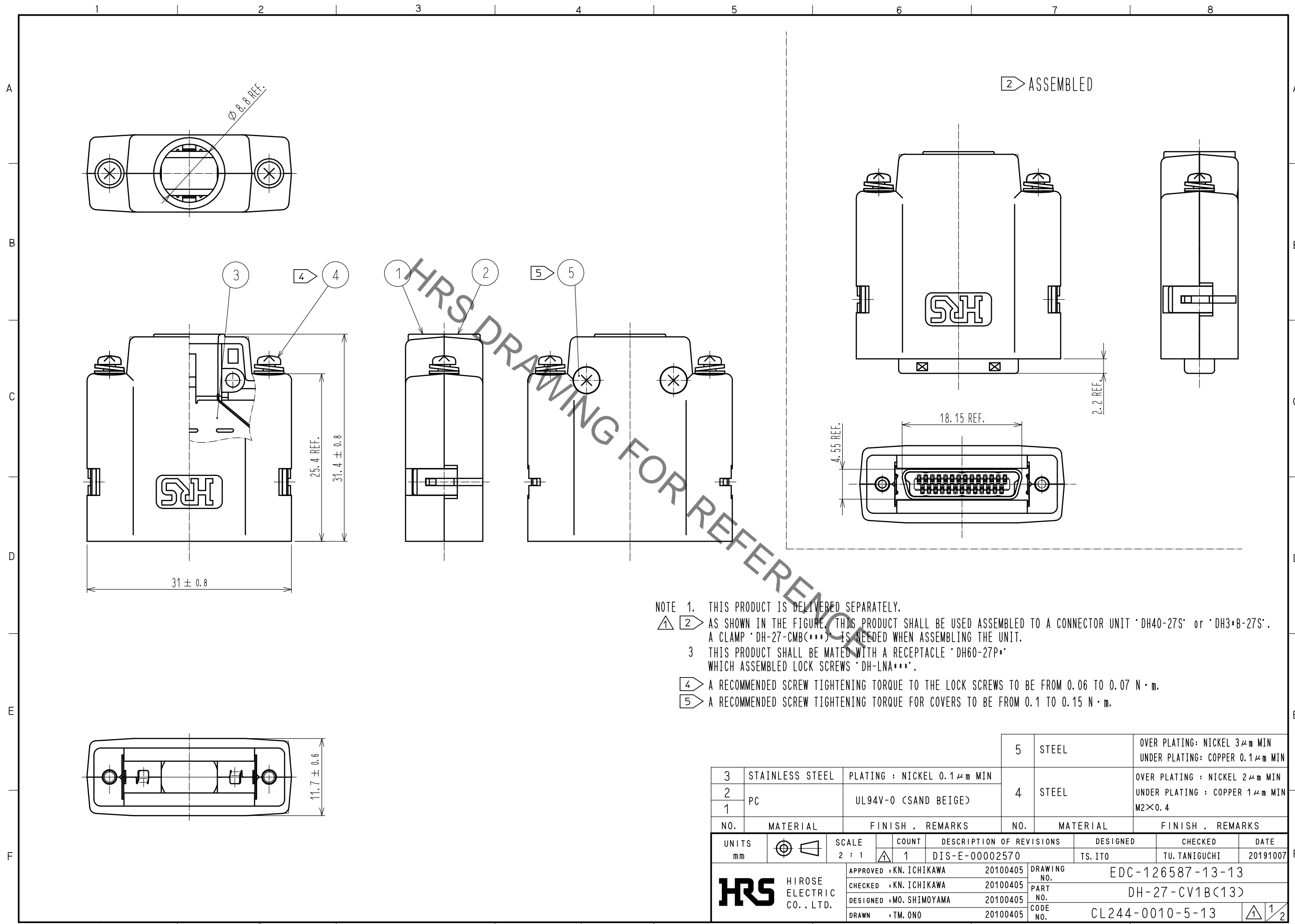

- NOTE 1. THIS PRODUCT IS DELIVERED SEPARATELY.
- △ 2 AS SHOWN IN THE FIGURE, THIS PRODUCT SHALL BE USED ASSEMBLED TO A CONNECTOR UNIT 'DH40-27S' or 'DH3+B-27S'. A CLAMP 'DH-27-CMB(***)' IS NEEDED WHEN ASSEMBLING THE UNIT.
- 3 THIS PRODUCT SHALL BE MATED WITH A RECEPTACLE 'DH60-27P*' WHICH ASSEMBLED LOCK SCREWS 'DH-LNA***'.
- 4 A RECOMMENDED SCREW TIGHTENING TORQUE TO THE LOCK SCREWS TO BE FROM 0.06 TO 0.07 N · m.
- 5 A RECOMMENDED SCREW TIGHTENING TORQUE FOR COVERS TO BE FROM 0.1 TO 0.15 N · m.

NO.	MATERIAL	FINISH . REMARKS	NO.	MATERIAL	FINISH . REMARKS
3	STAINLESS STEEL	PLATING : NICKEL 0.1 μm MIN	5	STEEL	OVER PLATING: NICKEL 3 μm MIN UNDER PLATING: COPPER 0.1 μm MIN
2	PC	UL94V-0 (SAND BEIGE)	4	STEEL	OVER PLATING : NICKEL 2 μm MIN UNDER PLATING : COPPER 1 μm MIN M2×0.4
1					

UNITS	SCALE	COUNT	DESCRIPTION OF REVISIONS	DESIGNED	CHECKED	DATE
mm	2 : 1	1	DIS-E-00002570	TS. ITO	TU. TANIGUCHI	20191007

APPROVED : KN. ICHIKAWA	20100405	DRAWING NO.	EDC-126587-13-13
CHECKED : KN. ICHIKAWA	20100405	PART NO.	DH-27-CV1B(13)
DESIGNED : MO. SHIMOYAMA	20100405	CODE NO.	CL244-0010-5-13
DRAWN : TM. ONO	20100405		

Jun.1.2020 Copyright 2020 HIROSE ELECTRIC CO., LTD. All Rights Reserved.
In case of consideration for using Automotive equipment / device which demand high reliability, kindly contact our sales window correspondents.

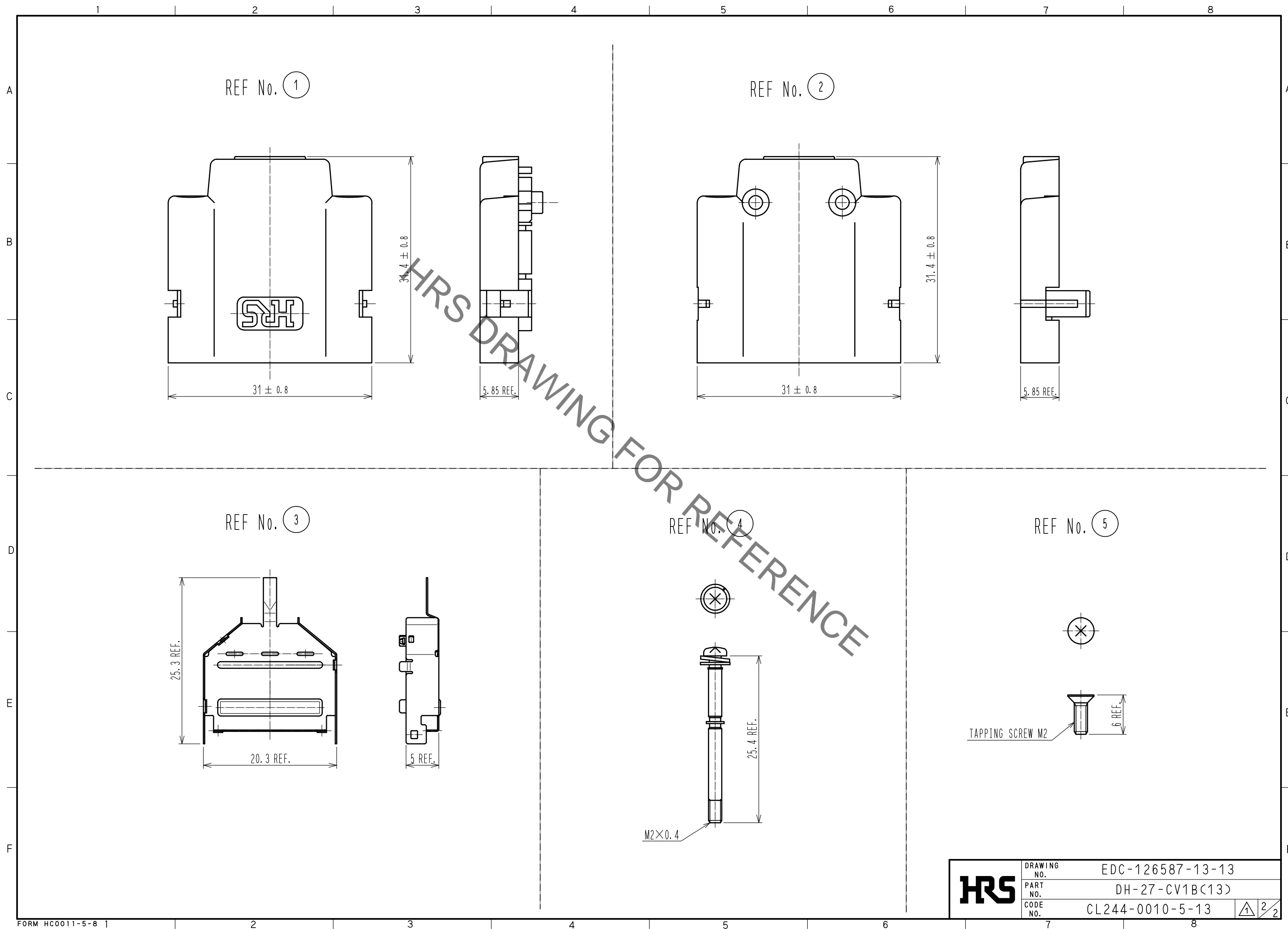

HRS	DRAWING NO.	EDC-126587-13-13
	PART NO.	DH-27-CV1B(13)
	CODE NO.	CL244-0010-5-13
		2/2