

UNCONTROLLED DOCUMENT

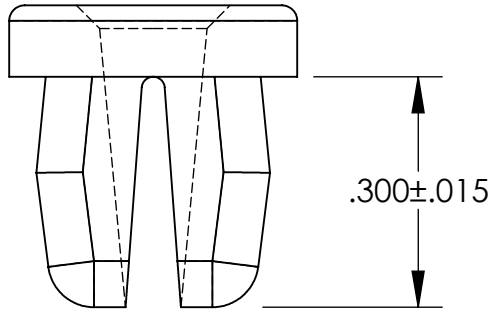
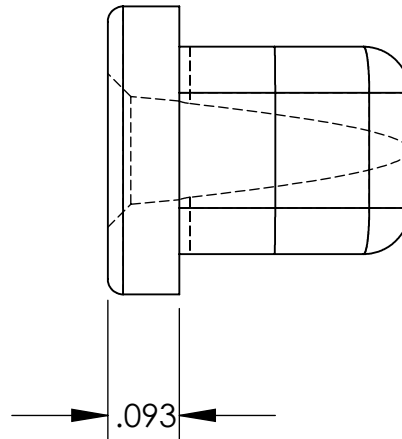
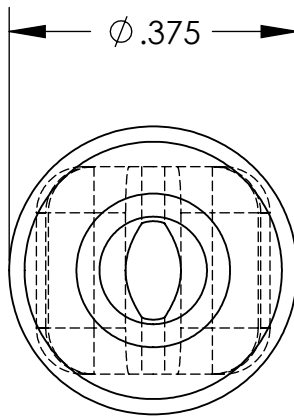

NOTES:
 HOLE SIZE .270 / .280
 PANEL THICKNESS RANGE .062 / .165
 SCREW SIZE #6

TOLERANCES UNLESS NOTED

- $\pm .005$ ON DIMENSIONS THRU $.625$
- $\pm .008$ ON DIMENSIONS $.626$ THRU 1.000
- $\pm .010$ ON DIMENSIONS 1.001 THRU 1.500
- $\pm .015$ ON DIMENSIONS LARGER THAN 1.500
- $\pm .015$ ON FRACTIONAL DIMENSIONS

WE RESERVE THE RIGHT
 TO DISCONTINUE ITEMS,
 CHANGE SPECIFICATIONS
 OR DESIGN AT ANY TIME
 WITHOUT NOTICE AND
 WITHOUT INCURRING
 ANY OBLIGATIONS

PROPERTY OF		
MICRO PLASTICS INC.		
CATALOG DRAWING ROUND HEAD GROMMET NUT MICRO P/N 60SGN00009 DWG. # 60SGN00009 FILE SERVER\ENG\WEB		
MATERIAL:		NYLON 6/6
DATE	SCALE	DB
	4:1	