



CY8CKIT-041-40XX

PSoC[®] 4 S-Series Pioneer Kit Guide

Doc. # 002-10238 Rev. *D

Cypress Semiconductor
198 Champion Court
San Jose, CA 95134-1709
www.cypress.com

Copyrights

© Cypress Semiconductor Corporation, 2016–2019. This document is the property of Cypress Semiconductor Corporation and its subsidiaries (“Cypress”). This document, including any software or firmware included or referenced in this document (“Software”), is owned by Cypress under the intellectual property laws and treaties of the United States and other countries worldwide. Cypress reserves all rights under such laws and treaties and does not, except as specifically stated in this paragraph, grant any license under its patents, copyrights, trademarks, or other intellectual property rights. If the Software is not accompanied by a license agreement and you do not otherwise have a written agreement with Cypress governing the use of the Software, then Cypress hereby grants you a personal, non-exclusive, nontransferable license (without the right to sublicense) (1) under its copyright rights in the Software (a) for Software provided in source code form, to modify and reproduce the Software solely for use with Cypress hardware products, only internally within your organization, and (b) to distribute the Software in binary code form externally to end users (either directly or indirectly through resellers and distributors), solely for use on Cypress hardware product units, and (2) under those claims of Cypress’s patents that are infringed by the Software (as provided by Cypress, unmodified) to make, use, distribute, and import the Software solely for use with Cypress hardware products. Any other use, reproduction, modification, translation, or compilation of the Software is prohibited.

TO THE EXTENT PERMITTED BY APPLICABLE LAW, CYPRESS MAKES NO WARRANTY OF ANY KIND, EXPRESS OR IMPLIED, WITH REGARD TO THIS DOCUMENT OR ANY SOFTWARE OR ACCOMPANYING HARDWARE, INCLUDING, BUT NOT LIMITED TO, THE IMPLIED WARRANTIES OF MERCHANTABILITY AND FITNESS FOR A PARTICULAR PURPOSE. No computing device can be absolutely secure. Therefore, despite security measures implemented in Cypress hardware or software products, Cypress shall have no liability arising out of any security breach, such as unauthorized access to or use of a Cypress product. CYPRESS DOES NOT REPRESENT, WARRANT, OR GUARANTEE THAT CYPRESS PRODUCTS, OR SYSTEMS CREATED USING CYPRESS PRODUCTS, WILL BE FREE FROM CORRUPTION, ATTACK, VIRUSES, INTERFERENCE, HACKING, DATA LOSS OR THEFT, OR OTHER SECURITY INTRUSION (collectively, “Security Breach”). Cypress disclaims any liability relating to any Security Breach, and you shall and hereby do release Cypress from any claim, damage, or other liability arising from any Security Breach. In addition, the products described in these materials may contain design defects or errors known as errata which may cause the product to deviate from published specifications. To the extent permitted by applicable law, Cypress reserves the right to make changes to this document without further notice. Cypress does not assume any liability arising out of the application or use of any product or circuit described in this document. Any information provided in this document, including any sample design information or programming code, is provided only for reference purposes. It is the responsibility of the user of this document to properly design, program, and test the functionality and safety of any application made of this information and any resulting product. “High-Risk Device” means any device or system whose failure could cause personal injury, death, or property damage. Examples of High-Risk Devices are weapons, nuclear installations, surgical implants, and other medical devices. “Critical Component” means any component of a High-Risk Device whose failure to perform can be reasonably expected to cause, directly or indirectly, the failure of the High-Risk Device, or to affect its safety or effectiveness. Cypress is not liable, in whole or in part, and you shall and hereby do release Cypress from any claim, damage, or other liability arising from any use of a Cypress product as a Critical Component in a High-Risk Device. You shall indemnify and hold Cypress, its directors, officers, employees, agents, affiliates, distributors, and assigns harmless from and against all claims, costs, damages, and expenses, arising out of any claim, including claims for product liability, personal injury or death, or property damage arising from any use of a Cypress product as a Critical Component in a High-Risk Device. Cypress products are not intended or authorized for use as a Critical Component in any High-Risk Device except to the limited extent that (i) Cypress’s published data sheet for the product explicitly states Cypress has qualified the product for use in a specific High-Risk Device, or (ii) Cypress has given you advance written authorization to use the product as a Critical Component in the specific High-Risk Device and you have signed a separate indemnification agreement.

Cypress, the Cypress logo, Spansion, the Spansion logo, and combinations thereof, WICED, PSoC, CapSense, EZ-USB, F-RAM, and Traveo are trademarks or registered trademarks of Cypress in the United States and other countries. For a more complete list of Cypress trademarks, visit cypress.com. Other names and brands may be claimed as property of their respective owners.

Contents



| | |
|---|-----------|
| Safety Information | 4 |
| 1. Introduction | 5 |
| 1.1 Kit Contents | 5 |
| 1.2 Board Details | 6 |
| 1.3 PSoC Creator | 11 |
| 1.4 Getting Started..... | 14 |
| 1.5 Additional Learning Resources | 14 |
| 1.6 Technical Support..... | 15 |
| 1.7 Documentation Conventions..... | 15 |
| 1.8 Acronyms | 15 |
| 2. Software Installation | 17 |
| 2.1 Before You Begin..... | 17 |
| 2.2 Install Software | 17 |
| 2.3 Uninstall Software | 19 |
| 3. Kit Operation | 20 |
| 3.1 Theory of Operation..... | 20 |
| 3.2 KitProg2 | 29 |
| 4. Code Examples | 32 |
| 4.1 Using the Kit Code Examples | 32 |
| 4.2 Code Examples | 34 |
| A. Appendix | 36 |
| A.1 Schematics | 36 |
| A.2 Hardware Functional Description..... | 36 |
| A.3 Using the FM24V10 F-RAM..... | 44 |
| A.4 Using EZ-BLE PProC Module..... | 46 |
| A.5 Migrating Projects Across Different Pioneer Series Kits | 48 |
| A.6 Bill of Materials | 52 |
| Revision History | 53 |

Safety Information



Regulatory Compliance

The CY8CKIT-041-40XX PSoC[®] 4 S-Series Pioneer Kit is intended for use as a development platform for hardware or software in a laboratory environment. The board is an open system design, which does not include a shielded enclosure. This may cause interference to other electrical or electronic devices in close proximity. In a domestic environment, this product may cause radio interference. In such cases, you may be required to take adequate preventive measures. In addition, this board should not be used near any medical equipment or RF devices.

Attaching additional wiring to this product or modifying the product operation from the factory default may affect its performance and cause interference with other apparatus in the immediate vicinity. If such interference is detected, suitable mitigating measures should be taken.

The PSoC 4 S-Series Pioneer Kit, as shipped from the factory, has been verified to meet with the requirements of CE as a Class A product.



The PSoC 4 S-Series Pioneer Kit contains electrostatic discharge (ESD) sensitive devices. Electrostatic charges readily accumulate on the human body and any equipment, and can discharge without detection. Permanent damage may occur on devices subjected to high-energy discharges. Proper ESD precautions are recommended to avoid performance degradation or loss of functionality. Store unused PSoC 4 S-Series Pioneer kit in the protective shipping package.



End-of-Life/Product Recycling

The end-of life for this kit is five years from the date of manufacture mentioned as bar code on the back of the box. Contact your nearest recycler for discarding the kit.

General Safety Instructions

ESD Protection

ESD can damage boards and associated components. Cypress recommends that you perform procedures only at an ESD workstation. If an ESD workstation is not available, use appropriate ESD protection by wearing an antistatic wrist strap attached to a grounded metal object.

Handling Boards

PSoC 4 S-Series Pioneer Kit is sensitive to ESD. Hold the board only by its edges. After removing the board from its box, place it on a grounded, static-free surface. Use a conductive foam pad if available. Do not slide the board over any surface.

1. Introduction



Thank you for your interest in the CY8CKIT-041-40XX PSoC[®] 4 S-Series Pioneer Kit. This kit enables you to evaluate and develop your application using the PSoC 4000S device family.

The PSoC 4000S device family is an expansion to the PSoC 4 device family. PSoC 4000S device is a true programmable embedded system-on-chip, integrating custom analog and digital peripheral functions, memory, and an ARM[®] Cortex[®]-M0+ microcontroller on a single chip. The programmable analog and digital peripheral functions allow higher flexibility, in-field tuning of the design, and faster time-to-market.

The PSoC 4 S-Series Pioneer Kit offers footprint-compatibility with Arduino[™] shields. This kit features a CapSense[®] trackpad, two CapSense buttons, a CapSense proximity sensor that lets you evaluate Cypress's fourth-generation CapSense technology, an RGB LED, two user-configurable push-button switches, potentiometer, an onboard programmer/debugger with USB-UART/I2C bridge functionality block (KitProg2), a Cypress F-RAM[™], an EZ-BLE[™] PSoC[™] Module, and a rechargeable battery. This kit supports operating voltages of 1.9 V, 3 V (battery), 3.3 V or 5 V.

You will use PSoC Creator[™] to develop and debug your PSoC 4000S device projects. PSoC Creator is Cypress's standard integrated design environment (IDE). If you are new to PSoC Creator, see the documentation on the [PSoC Creator home page](#). You can also refer the application note [AN79953 – Getting Started with PSoC 4](#), which gives an introduction to the PSoC 4 device.

1.1 Kit Contents

The CY8CKIT-041-40XX PSoC 4 S-Series Pioneer Kit contains the following, as shown in [Figure 1-1](#).

- PSoC 4 S-Series Pioneer Kit
- USB Standard-A to Micro-B cable
- Water dropper
- Four press-fit connectors (one 8x2, one 10x1, two 8x1)
- Four jumper wires
- Quick Start Guide

Figure 1-1. Kit Contents



Inspect the contents of the kit; if you find any part missing, contact your nearest Cypress sales office for help: www.cypress.com/support.

1.2 Board Details

As shown in [Figure 1-2](#), the PSoC 4 S-Series Pioneer Kit features a CapSense trackpad, two CapSense buttons, and a proximity sensor loop (not visible on the case) that lets you evaluate Cypress's fourth-generation CapSense technology. The kit has two user buttons, an RGB LED and a potentiometer that can be used in your applications. It also has a reset button and three status LEDs. The kit can be powered from three power sources: USB connector, rechargeable battery or external power supply. The kit can operate at 1.9 V, 3.3 V, and 5 V when powered from the USB connector or external power supply and will operate at 3 V when powered from the battery. The USB connector is also used for programming and debugging your application on PSoC 4000S.

Figure 1-2. PSoC 4 S-Series Pioneer Kit



- | | |
|-----------------------------------|-------------------------|
| 1. KitProg2 Status LEDs | 4. Potentiometer |
| 2. Power LED | 5. Reset button |
| 3. KitProg2 USB Micro-B connector | 6. User button |
| | 7. KitProg2 user button |

Figure 1-3. PSoC 4 S-Series Pioneer Kit without Overlay

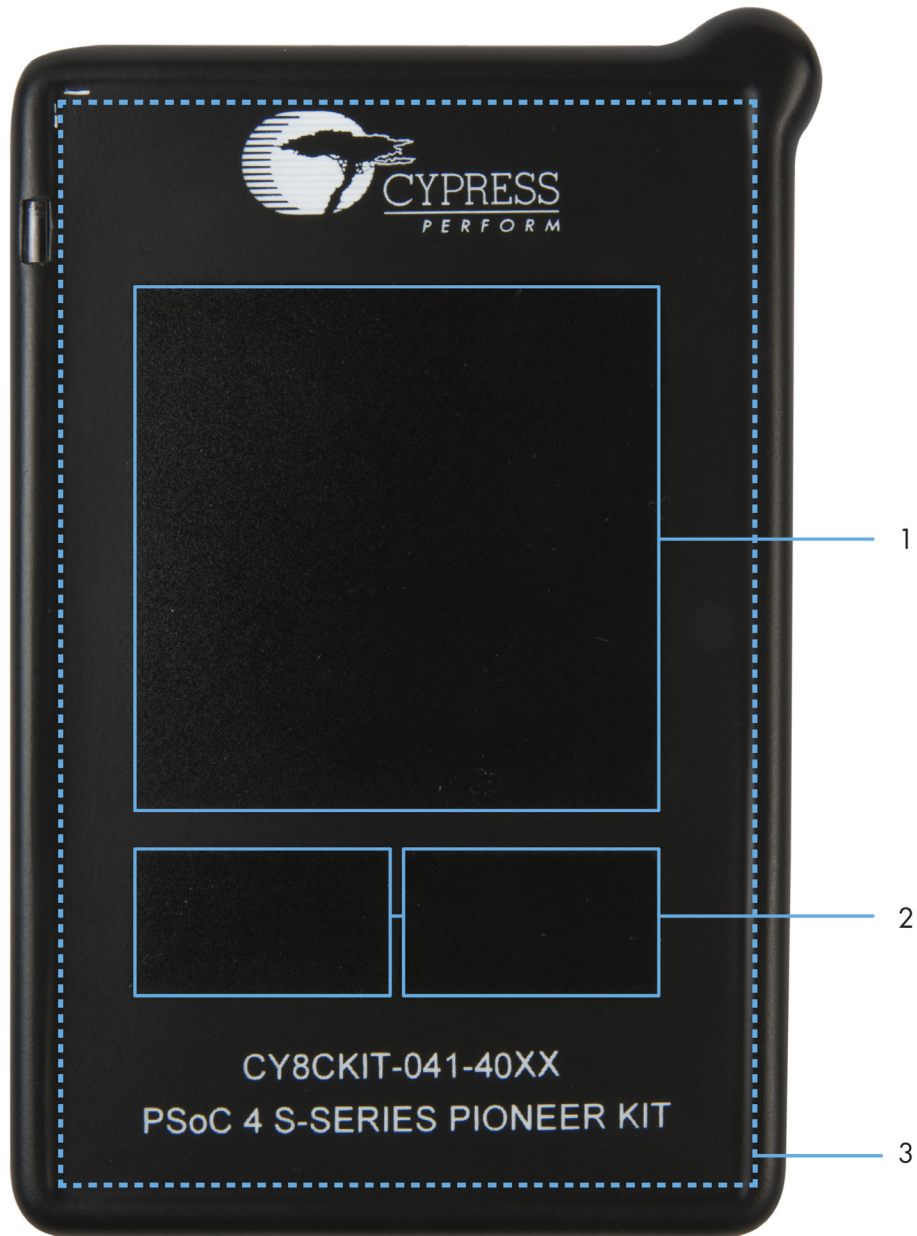

- | | |
|----------------------|--------------------------|
| 1. CapSense trackpad | 2. CapSense buttons |
| | 3. Proximity sensor loop |

Note: The above figure shows the kit without color gamut overlay

Figure 1-4. PSoC 4 S-Series Pioneer board (Top View)

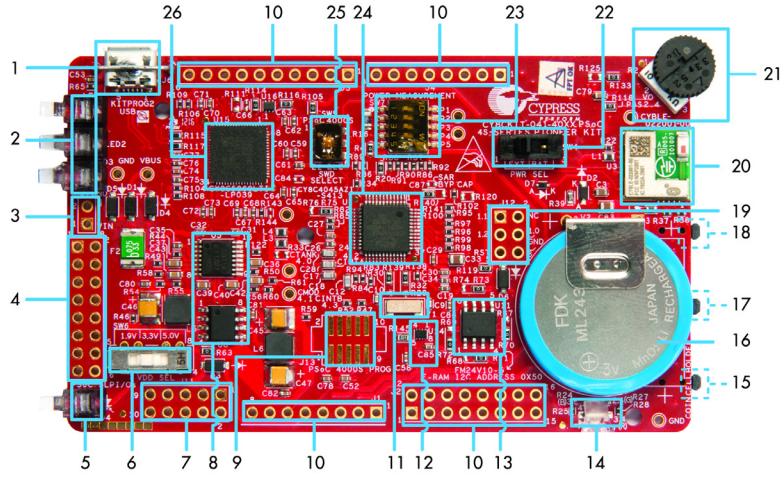

- | | |
|---|---|
| 1. KitProg2 USB Micro-B connector (J6) | 14. RGB LED (LED5) |
| 2. KitProg2 status LEDs (LED1, LED2 and LED3) | 15. KitProg2 user button (SW3) |
| 3. External power supply header (J7) | 16. Rechargeable battery (ML2430-HS1, V2) |
| 4. KitProg2 (PSoC 5LP) I/O header (J8) | 17. User Button (SW2) |
| 5. Power LED (LED4) | 18. Reset button (SW1) |
| 6. System power (VDD) selection switch (SW6) | 19. Arduino ICSP compatible header (J12) |
| 7. KitProg2 custom application/programming header (J11) | 20. EZ-BLE™ PSoC™ Module (CYBLE-022001-00, U3) |
| 8. Voltage regulator circuit | 21. Potentiometer (R2) |
| 9. PSoC 4000S 10-pin program and debug header (J13) | 22. VDD source selection switch (SW4) |
| 10. Arduino™ compatible power and I/O headers (J1, J2, J3 and J4) | 23. Current measurement selection switch (SW7) |
| 11. 32.768 kHz crystal oscillator (Y1) | 24. PSoC 4000S (U1) |
| 12. Voltage Level Translator for F-RAM (U14) | 25. Programming target (PSoC 4000S/EZ-BLE PSoC) module selection switch (SW5) |
| 13. Cypress F-RAM 1Mb (FM24V10-G, U11) | 26. KitProg2 (PSoC 5LP) programmer and debugger (U15) |

Figure 1-5. PSoC 4 S-Series Pioneer board (Bottom View)

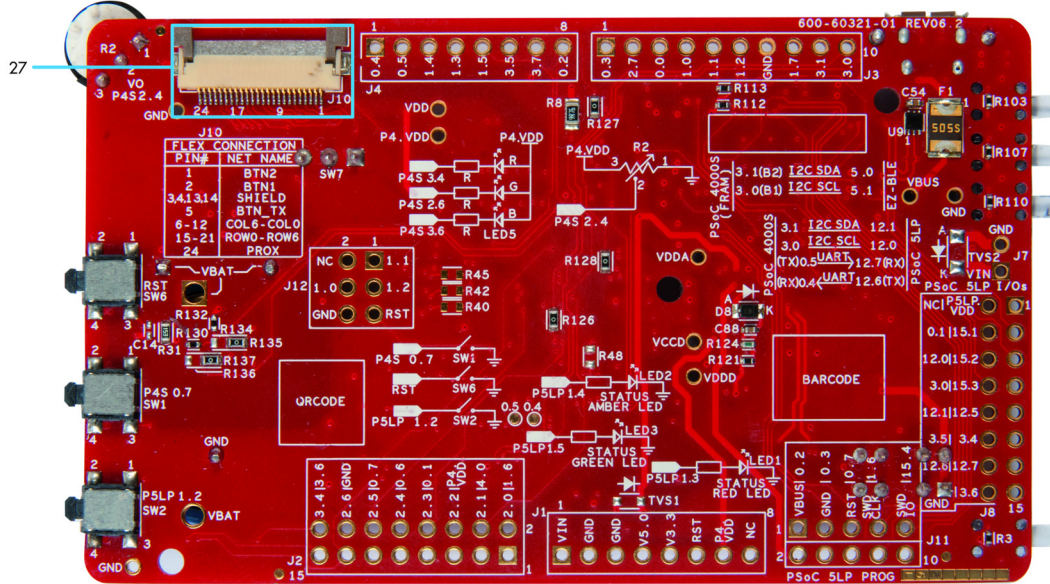

27. Flex connector

Figure 1-6. PSoC 4 S-Series Pioneer Board Pinout

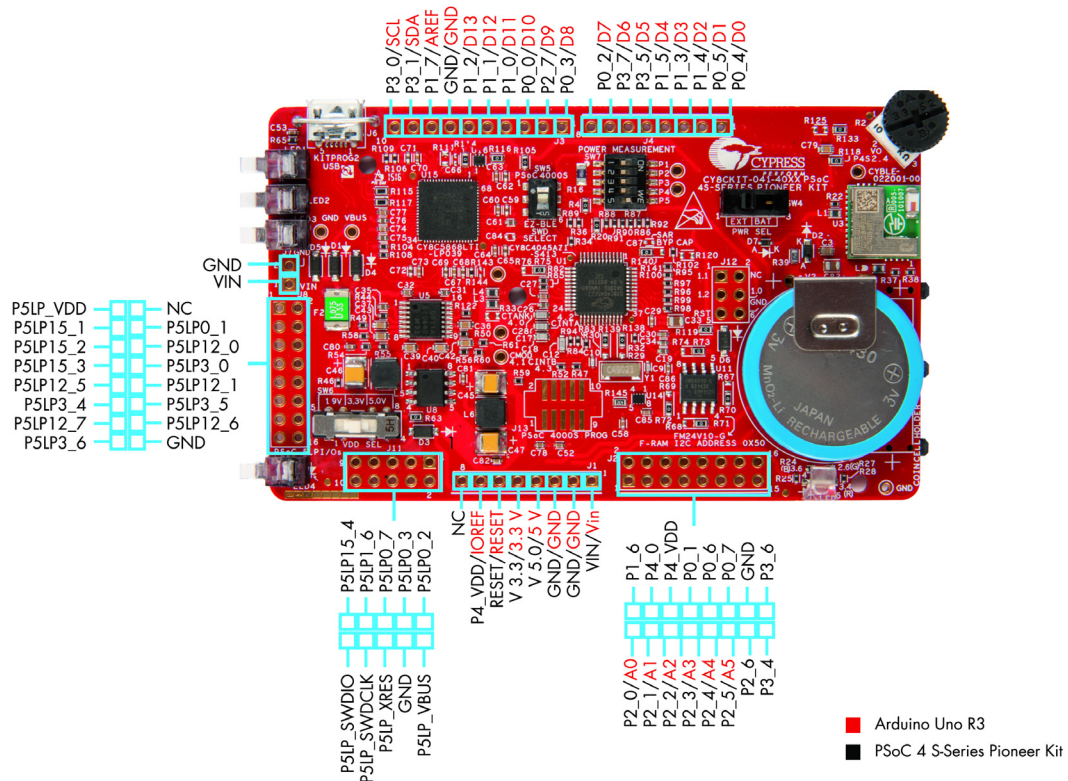

Table 1-1. Jumpers/Switches Default Position

| Jumper/Switch | Purpose | Default Position |
|---------------|-------------------------------|--|
| SW4 (PWR SEL) | VDD Source Selection | EXT (VREG/VBUS) |
| SW5 | Programming Target Selection | PSoC 4000S |
| SW6 | System Power (VDD) Selection | 5 V |
| SW7 | Current Measurement Selection | Switches P1, P2, P3, and P4 – OFF; Switch P5 – ON |

1.3 PSoC Creator

PSoC Creator is a state-of-the-art, easy-to-use IDE. It introduces revolutionary hardware and software co-design, powered by a library of fully verified and characterized PSoC Components™, as shown in Figure 1-7. With PSoC Creator, you can:

1. Drag and drop Components to build your hardware system design in the main design workspace
2. Co-design your application firmware with the PSoC hardware
3. Configure Components using configuration tools
4. Explore the library of 100+ Components
5. Access Component datasheets

Figure 1-7. PSoC Creator Features

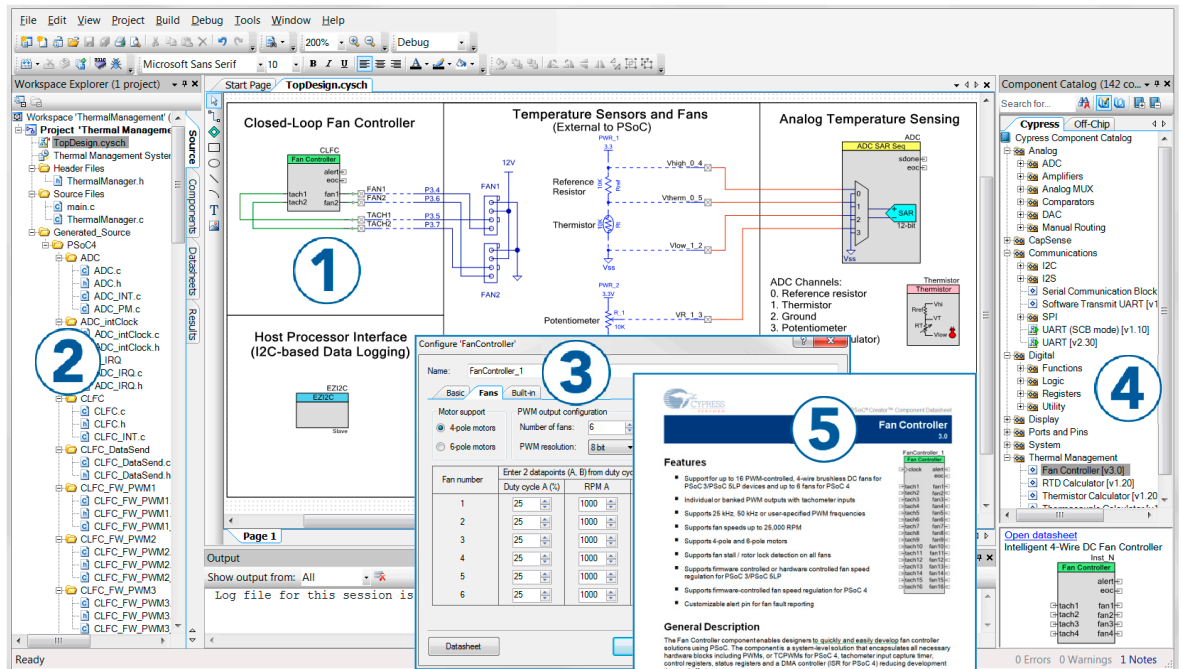

PSoC Creator also enables you to tap into an entire tool ecosystem with integrated compiler chains and production programmers for PSoC devices.

For more information, visit www.cypress.com/psoccreator.

1.3.1 PSoC Creator Code Examples

PSoC Creator includes a large number of code examples. These examples are accessible from the PSoC Creator Start Page, as shown in [Figure 1-8](#).

Code examples can speed up your design process by starting you off with a complete design. The code examples also show how to use PSoC Creator Components for various applications. Code examples and documentation are included, as shown in [Figure 1-9](#).

In the **Find Code Example** dialog shown in [Figure 1-9](#), you have several options:

- Filter for examples based on device family or keyword.
- Select from the list of examples offered based on the **Filter Options**.
- View the project documentation for the selection (on the **Documentation** tab).
- View the code for the selection on the **Sample Code** tab. You can also copy and paste code from this window to your project, which can help speed up code development.
- Create a new workspace for the code example or add to your existing workspace. This can speed up your design process by starting you off with a complete, basic design. You can then adapt that design to your application.

Figure 1-8. Code Examples in PSoC Creator

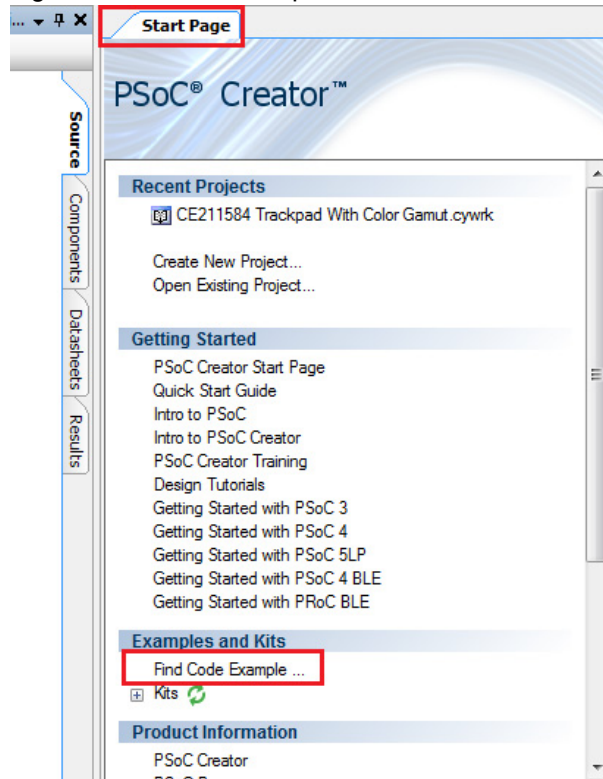
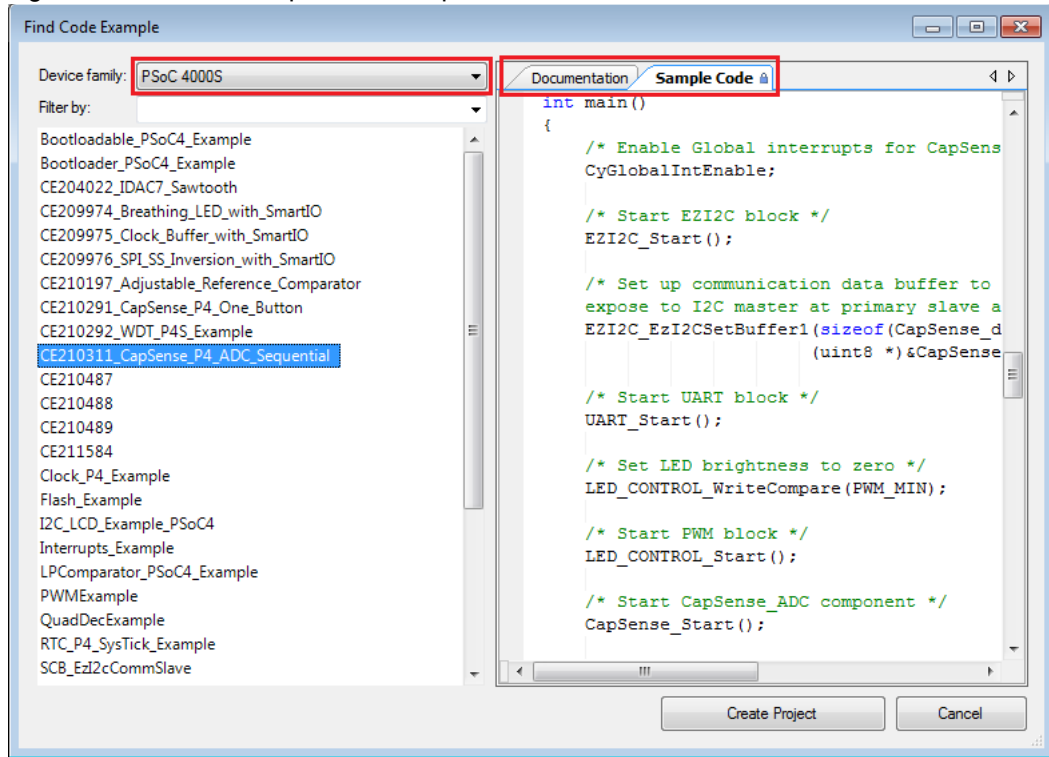

Figure 1-9. Code Example with Sample Code



1.3.2 Kit Code Examples

You can access the installed kit code examples from the PSoC Creator Start Page. To access these examples, expand the Kits under the section Examples and Kits; then, expand the specific kit to see the code examples. Refer to the [Code Examples chapter on page 32](#) for a list of code examples that you can use on this kit.

1.3.3 PSoC Creator Help

Launch PSoC Creator and navigate to the following items:

- **Quick Start Guide:** Choose **Help > Documentation > Quick Start Guide**. This guide gives you the basics for developing PSoC Creator projects.
- **Simple Component Code Examples:** Choose **File > Code Example**. These examples demonstrate how to configure and use PSoC Creator Components. To access examples related to a specific Component, right-click on the Component in the schematic or in the Component Catalog. Select the **Find Code Example** option in the context menu that appears.
- **System Reference Guide:** Choose **Help > System Reference > System Reference Guide**. This guide lists and describes the system functions provided by PSoC Creator.
- **Component Datasheets:** Right-click a Component and select **Open Datasheet**. Visit the [PSoC 4 Component Datasheets](#) page for a list of all PSoC 4 Component datasheets.
- **Document Manager:** PSoC Creator provides a document manager to help you easily find and access the document resources. To open the document manager, choose the menu item **Help > Document Manager**.

1.4 Getting Started

This guide will help you be acquainted with the PSoC 4 S-Series Pioneer Kit:

- The [Software Installation chapter on page 17](#) describes the installation of the kit software. This includes the PSoC Creator IDE to develop and debug the applications, and PSoC Programmer to program the `.hex` files on to the device.
- The [Kit Operation chapter on page 20](#) describes the major features of the PSoC 4 S-Series Pioneer Kit and functionalities such as programming, debugging, and the USB-UART and USB-I2C bridges.
- The [Code Examples chapter on page 32](#) describes multiple PSoC 4000S code examples that will help you understand how to create your own PSoC 4 projects.
- The [Appendix on page 36](#) provides the detailed hardware description, method to use the onboard F-RAM, method to use the on board EZ-BLE PSoC Module, kit schematics, and the bill of materials (BOM).

1.5 Additional Learning Resources

Cypress provides a wealth of data at www.cypress.com to help you to select the right PSoC device for your design, and to help you to quickly and effectively integrate the device into your design. For a comprehensive list of resources, see [KBA86521](#), [How to Design with PSoC 3, PSoC 4, and PSoC 5LP](#). The following is an abbreviated list for PSoC 4:

- Overview: [PSoC Portfolio](#) and [PSoC Roadmap](#).
- Product Selectors: [PSoC 4 Product Selector](#). In addition, [PSoC Creator](#) includes a device selection tool.
- Datasheets: Describe and provide electrical specifications for the [PSoC 4000](#), [PSoC 4100](#), [PSoC 4200](#), [PSoC 4100M](#), [PSoC 4200M](#), [PSoC 4200L](#), [PSoC 4000S](#) and [PSoC 4100S](#) device families.
- [CapSense Design Guide](#): Learn how to design capacitive touch-sensing applications with the PSoC 4 family of devices.
- [Application Notes](#) and [Code Examples](#): Cover a broad range of topics, from basic to advanced. Many of the application notes include code examples. Visit the [PSoC 3/4/5 Code Examples](#) web page for a list of all available PSoC Creator code examples. To access code examples from within PSoC Creator – see [PSoC Creator Code Examples on page 12](#).
- [Technical Reference Manuals \(TRM\)](#): Provide detailed descriptions of the architecture and registers in each PSoC 4 device family.
- [Development Kits](#):
 - [CY8CKIT-041-40XX](#), [CY8CKIT-041-41XX](#), [CY8CKIT-046](#), [CY8CKIT-044](#), [CY8CKIT-042](#) and [CY8CKIT-040](#) are easy-to-use and inexpensive development platforms. These kits include connectors for Arduino-compatible shields. Additionally, [CY8CKIT-046](#), [CY8CKIT-044](#), and [CY8CKIT-042](#) include connectors for Digilent Pmod Peripheral Modules.
 - [CY8CKIT-049](#), [CY8CKIT-043](#) and [CY8CKIT-145-40XX](#) are very low-cost prototyping platform for sampling PSoC 4 devices.
 - [CY8CKIT-001](#) is a common development platform for all PSoC family devices.
 - [MiniProg3](#) device provides an interface for flash programming and debug.
- [Knowledge Base Articles \(KBA\)](#): Provide design and application tips from experts on using the device.
- Visit www.cypress.com/training for a set of tutorials, including PSoC Creator training. Each tutorial is a series of videos that provide practical examples on various topics starting with basic concepts and moving on to more advanced features.

1.6 Technical Support

For assistance, visit [Cypress Support](#) or contact customer support at +1(800) 541-4736 Ext. 2 (in the USA) or +1 (408) 943-2600 Ext. 2 (International).

You can also use the following support resources if you need quick assistance:

- [Self-help \(Technical Documents\)](#)
- [Local Sales Office Locations](#)

1.7 Documentation Conventions

Table 1-2. Document Conventions for Guides

| Convention | Usage |
|--------------------|---|
| Courier New | Displays file locations, user entered text, and source code: C:\...cd\iccc\ |
| <i>Italics</i> | Displays file names and reference documentation: Read about the <i>sourcefile.hex</i> file in the <i>PSoC Creator User Guide</i> . |
| [Bracketed, Bold] | Displays keyboard commands in procedures: [Enter] or [Ctrl] [C] |
| File > Open | Represents menu paths: File > Open > New Project |
| Bold | Displays commands, menu paths, and icon names in procedures: Click the File icon and then click Open . |
| Times New Roman | Displays an equation: $2 + 2 = 4$ |
| Text in gray boxes | Describes cautions or unique functionality of the product. |

1.8 Acronyms

Table 1-3. Acronyms Used in this Document

| Acronym | Definition |
|---------|------------------------------------|
| ADC | Analog-to-Digital Converter |
| BLE | Bluetooth Low Energy |
| BOM | Bill of Materials |
| CINT | Integration Capacitor |
| CMOD | Modulator Capacitor |
| CPU | Central Processing Unit |
| CSD | CapSense Sigma Delta |
| CTANK | Shield Tank Capacitor |
| DC | Direct Current |
| Del-Sig | Delta-Sigma |
| ESD | Electrostatic Discharge |
| F-RAM | Ferroelectric Random Access Memory |

Table 1-3. Acronyms Used in this Document (*continued*)

| Acronym | Definition |
|------------------|---|
| FPC | Flexible Printed Circuit |
| GPIO | General-Purpose Input/Output |
| HID | Human Interface Device |
| I ² C | Inter-Integrated Circuit |
| IC | Integrated Circuit |
| ICSP | In-Circuit Serial Programming |
| IDAC | Current Digital-to-Analog Converter |
| IDE | Integrated Development Environment |
| LED | Light-emitting Diode |
| PC | Personal Computer |
| PTC | Positive Temperature Coefficient |
| PRoC | Programmable Radio-on-Chip |
| PSoC | Programmable System-on-Chip |
| PWM | Pulse Width Modulation |
| RGB | Red Green Blue |
| SAR | Successive Approximation Register |
| SPI | Serial Peripheral Interface |
| SRAM | Serial Random Access Memory |
| SWD | Serial Wire Debug |
| UART | Universal Asynchronous Receiver Transmitter |
| USB | Universal Serial Bus |
| WCO | Watch Crystal Oscillator |

2. Software Installation



This chapter describes the steps to install the software tools and packages on a PC for using the PSoC 4 S-Series Pioneer Kit. This includes the IDE on which the projects will be built and used for programming.

2.1 Before You Begin

To install Cypress software, you will require administrator privileges. However, they are not required to run software that is already installed. Before you install the kit software, close any other Cypress software that is currently running.

2.2 Install Software

Follow these steps to install the PSoC 4 S-Series Pioneer Kit software:

1. Download the CY8CKIT-041-40XX PSoC 4 S-Series Pioneer Kit software from www.cypress.com/CY8CKIT-041. The kit software is available in three different formats for download.
 - a. **CY8CKIT-041-40XX Kit Complete Setup:** This installation package contains the files related to the kit including PSoC Creator and PSoC Programmer. However, it does not include the Windows Installer or Microsoft .NET framework packages. If these packages are not on your computer, the installer directs you to download and install them from the Internet.
 - b. **CY8CKIT-041-40XX Kit Only:** This executable file installs only the kit contents, which include kit code examples, hardware files, and user documents. This package can be used if all the software prerequisites (listed in step 5) are installed on your PC.
 - c. **CY8CKIT-041-40XX DVD ISO:** This file is a complete package, stored in a DVD-ROM image format, which you can use to create a DVD or extract using an ISO extraction program such as WinZip[®] or WinRAR. The file can also be mounted like a virtual CD/DVD using virtual drive programs such as Virtual CloneDrive and MagicISO. This file includes all the required software, utilities, drivers, hardware files, and user documents.
2. If you have downloaded the ISO file, mount it on a virtual drive. Extract the ISO contents if you do not have a virtual drive to mount. Double-click *cyautorun.exe* in the root directory of the extracted content or the mounted ISO if “Autorun from CD/DVD” is not enabled on the computer. The installation window will appear automatically.

Note: If you are using the “Kit Complete Setup” or “Kit Only” file, then go to step 4 for installation.

- Click **Install CY8CKIT-041-40XX** to start the PSoC 4 S-Series Pioneer Kit installation, as shown in Figure 2-1.

Figure 2-1. Kit Installer Screen



- Select the folder in which you want to install the PSoC 4 S-Series Pioneer Kit-related files. Choose the directory and click **Next**.
- When you click **Next**, the installer automatically installs the required software, if it is not present on your computer. Following are the required software:
 - PSoC Creator 4.0 or later: This software is available for download separately at www.cypress.com/psoccreator.
 - PSoC Programmer 3.25 or later: This is installed as part of PSoC Creator installation or is available separately at www.cypress.com/programmer.
- Choose the **Typical**, **Custom**, or **Complete** installation type (select **Typical** if you do not know which one to select) in the Product Installation Overview window, as shown in Figure 2-2. Click **Next** after you select the installation type.

Figure 2-2. Product Installation Overview

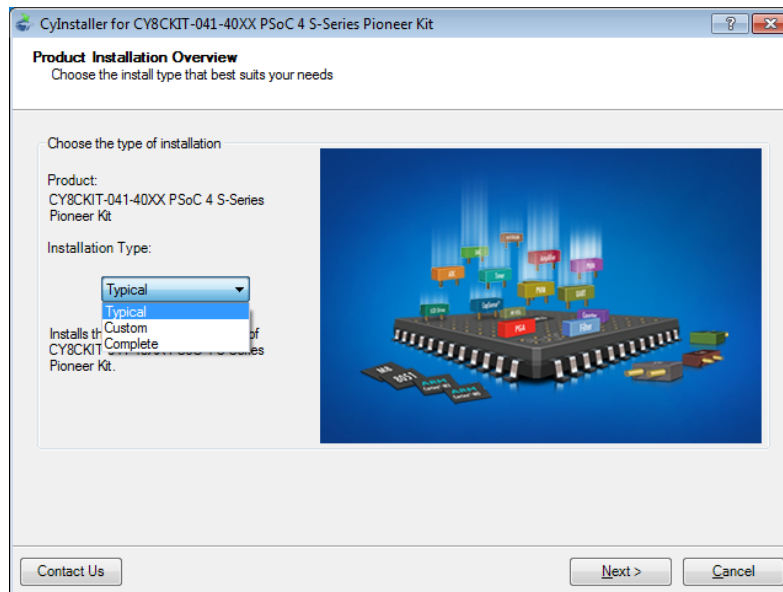

7. Read the License agreement and select **I accept the terms in the license agreement** to continue with installation. Click **Next**.
8. When the installation begins, a list of packages appears on the installation page. A green check mark appears next to each package after successful installation.
9. Enter your contact information or select the check box **Continue Without Contact Information**. Click **Finish** to complete the CY8CKIT-041-40XX PSoC 4 S-Series Pioneer Kit software installation.

10. After the installation is complete, the kit contents are available at the following location:

```
<Install_Directory>\CY8CKIT-041-40XX PSoC 4 S-Series Pioneer Kit
```

Default location:

Windows 7 (64-bit): C:\Program Files (x86)\Cypress\CY8CKIT-041-40XX PSoC 4 S-Series Pioneer Kit

Windows 7 (32-bit): C:\Program Files\Cypress\CY8CKIT-041-40XX PSoC 4 S-Series Pioneer Kit

Note: For Windows 7/8/8.1/10 users, the installed files and the folder are read only. To use the installed code examples, follow the steps outlined in the [Code Examples chapter on page 32](#). These steps will create an editable copy of the example in a path that you choose so the original installed example is not modified.

2.3 Uninstall Software

The software can be uninstalled using one of the following methods:

- Go to **Start > All Programs > Cypress > Cypress Update Manager** and select the **Uninstall** button that corresponds to the kit software.
- Go to **Start > Control Panel > Programs and Features** for Windows 7 or **Add/Remove Programs** for Windows XP; choose the product and select the **Uninstall/Change** button.

3. Kit Operation



This chapter introduces you to the various features of the PSoC 4 S-Series Pioneer Kit, including the theory of operation and the onboard programming and debugging functionality, KitProg2 USB-UART and USB-I2C bridges.

3.1 Theory of Operation

The PSoC 4 S-Series Pioneer Kit is built around the PSoC 4000S device. [Figure 3-1](#) shows the block diagram of the PSoC 4000S device.

Figure 3-1. PSoC 4000S Block Diagram

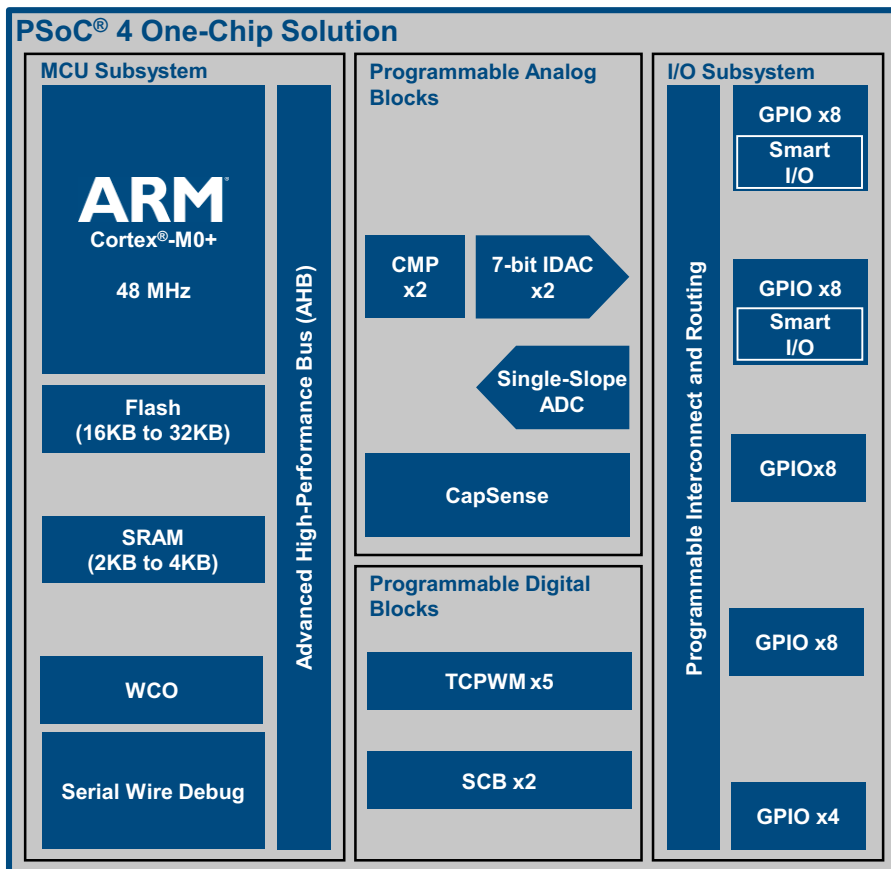

Given below is a list of major features of PSoC 4000S device.

- 32-Bit MCU Subsystem
 - 48-MHz ARM[®] Cortex[®]-M0+ CPU
 - Up to 32KB flash, 4KB SRAM
 - Real-time clock capability with a WCO
- Programmable Analog Blocks
 - One 10-bit, 46.8-Ksps Single-Slope ADC
 - Two low-power comparators (CMP)
 - One CapSense[®] block that supports low-power operation with self- and mutual-capacitance sensing
 - Two 7-bit IDACs configurable as a single 8-bit IDAC
- Programmable Digital Blocks
 - Five 16-bit Timer, Counter, PWM (TCPWM) blocks
 - Two serial communication blocks (SCBs) that are configurable as I²C, SPI or UART
- Packages
 - 25-ball WLCSP, 24-pin QFN, 32-pin QFN, 48-pin TQFP
 - Up to 36 GPIOs, including 16 Smart I/Os

Refer to the [PSoC 4000S datasheet](#) for details on device features.

Figure 3-2 shows the block diagram for the PSoC 4 S-Series Pioneer Kit.

Figure 3-2. Block Diagram of PSoC 4 S-Series Pioneer Kit

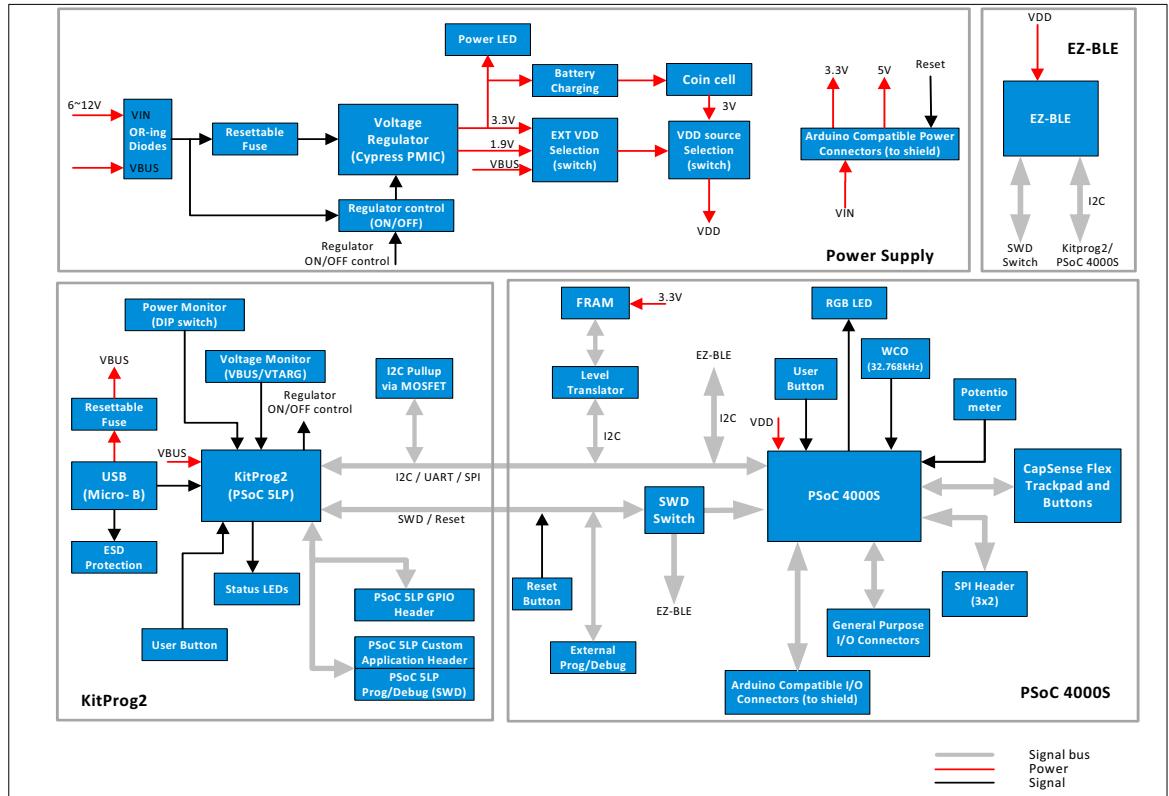

The PSoC 4 S-Series Pioneer Kit comes with a case that houses the PSoC 4 S-Series Pioneer board (main board) and a Flex PCB. Refer to [How to open the Kit Case](#) chapter on page 26 for details on opening the case.

Figure 3-3 shows the markup of PSoC 4 S-Series Pioneer board and the CapSense Flex PCB.

Figure 3-3. PSoC 4 S-Series Pioneer Board and Flex PCB

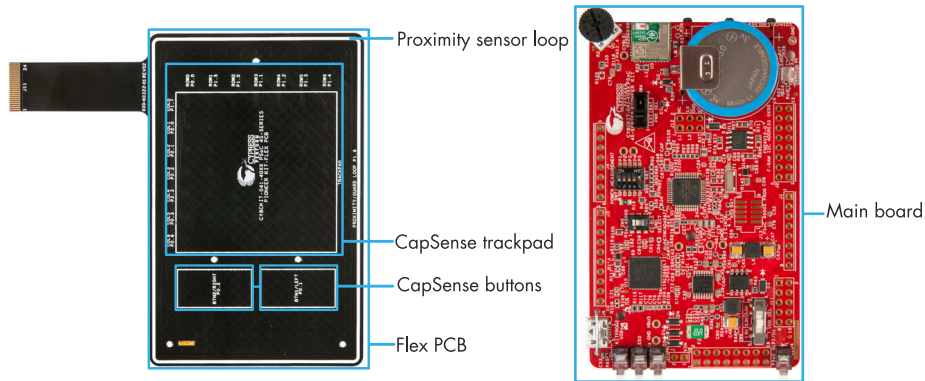

- PSoC 4 S-Series Pioneer Board (main board):

The PSoC 4 S-Series Pioneer board contains PSoC 4000S, KitProg2 circuit, rechargeable battery, EZ-BLE PRoC Module, F-RAM, switches, LEDs and voltage regulator.

- CapSense Flex PCB:

The Flex PCB has CapSense sensors including buttons, trackpad and proximity. The Flex PCB has two capacitive sensing buttons, a trackpad with seven row seven column, and a proximity sensor loop which is used for CapSense proximity sensing.

Figure 3-4 and Figure 3-5 shows the markup of the PSoC 4 S-Series Pioneer board.

Figure 3-4. PSoC 4 S-Series Pioneer Board (Top View)

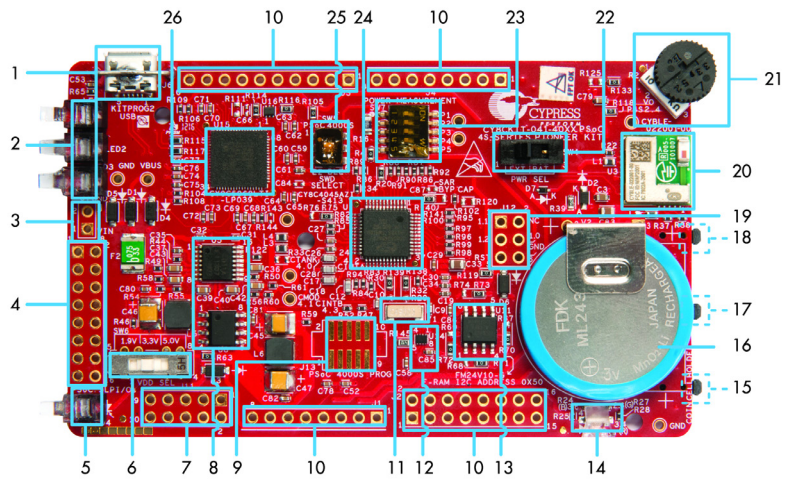

- | | |
|---|---|
| 1. KitProg2 USB Micro-B connector (J6) | 14. RGB LED (LED5) |
| 2. KitProg2 status LEDs (LED1, LED2 and LED3) | 15. KitProg2 user button (SW3) |
| 3. External power supply header (J7) | 16. Rechargeable battery (ML2430-HS1, V2) |
| 4. KitProg2 (PSoC 5LP) I/O header (J8) | 17. User Button (SW2) |
| 5. Power LED (LED4) | 18. Reset button (SW1) |
| 6. System power (VDD) selection switch (SW6) | 19. Arduino ICSP compatible header (J12) |
| 7. KitProg2 custom application/programming header (J11) | 20. EZ-BLE™ PRoC™ Module (CYBLE-022001-00, U3) |
| 8. Voltage regulator circuit | 21. Potentiometer (R2) |
| 9. PSoC 4000S 10-pin program and debug header (J13) | 22. VDD source selection switch (SW4) |
| 10. Arduino™ compatible power and I/O headers (J1, J2, J3 and J4) | 23. Current measurement selection switch (SW7) |
| 11. 32.768 kHz crystal oscillator (Y1) | 24. PSoC 4000S (U1) |
| 12. Voltage Level Translator for F-RAM (U14) | 25. Programming target (PSoC 4000S/EZ-BLE PRoC) module selection switch (SW5) |
| 13. Cypress F-RAM 1Mb (FM24V10-G, U11) | 26. KitProg2 (PSoC 5LP) programmer and debugger (U15) |

Figure 3-5. PSoC 4 S-Series Pioneer Board (Bottom View)

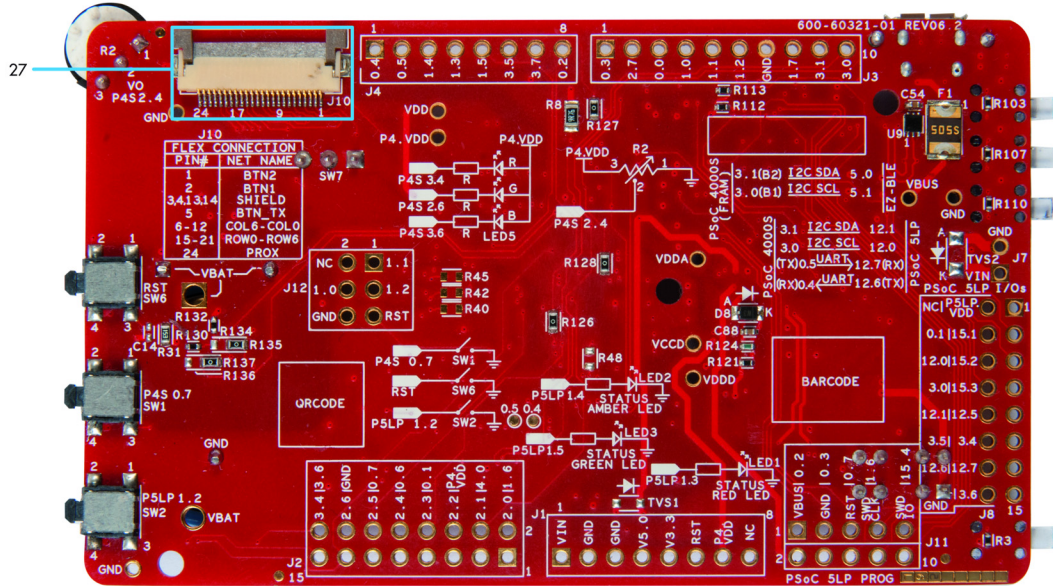

27. Flex connector

The PSoC 4 S-Series Pioneer board has the following peripherals:

1. **KitProg2 USB Micro-B connector (J6):** The USB cable provided along with the PSoC 4 S-Series Pioneer Kit connects between this USB connector and the PC.
2. **KitProg2 Status LEDs:** Red, amber, and green LEDs (LED1, LED2, and LED3) indicate the status of the KitProg2. For details on the KitProg2 status, refer to the [KitProg2 User Guide](#).
3. **External power supply (VIN) header (J7):** This header connects the external power supply input to the onboard regulator. The voltage input from the external supply can be between 6 V and 12 V.
4. **KitProg2 I/O header (J8):** This header brings out a few GPIOs of the onboard PSoC 5LP. This includes the USB-I2C bridge and USB-UART bridge lines. The additional PSoC 5LP pins are direct connections to the internal programmable analog logic of PSoC 5LP. You can also use these pins for custom applications. For more details on the KitProg2, refer to the [KitProg2 User Guide](#).
5. **Power LED (LED4):** The Amber power LED turns on when the kit is connected to a power source.
6. **System power (VDD) selection switch (SW6):** This switch selects the kit operating voltage. It can select between 1.9 V, 3.3 V and 5 V.
7. **KitProg2 custom application/programming header (J11):** This header brings out more GPIOs of the PSoC 5LP. It also contains a 5-pin SWD programming header for PSoC 5LP.
8. **Voltage regulator circuit:** The kit can operate at four voltage levels, 1.9 V, 3.3 V, 5 V from USB or external power supply and 3 V from the rechargeable battery. The kit has an onboard 2-channel regulator from Cypress that provides 3.3 V on one channel and 1.9 V on the other. 3 V is derived from the onboard battery and 5 V from the USB.
9. **PSoC 4000S 10-pin program and debug header (J13):** This 10-pin header allows you to program and debug the PSoC 4000S using an external programmer such as [MiniProg3](#). This header is not populated by default.

10. **Arduino-compatible power and I/O headers:** This kit is compatible and operates flawlessly with third-party Arduino shields. The Arduino-compatible power header (J1) powers Arduino shields. This header also has provision to power the kit through the VIN input pin. The Arduino-compatible I/O headers (J1, J2, J3 and J4) bring out the pins from PSoC 4000S to interface with the Arduino shields.
11. **32.768 kHz crystal oscillator (Y1):** This kit has a 32.768 kHz crystal oscillator to provide an accurate low-frequency clock for the PSoC 4000S.
12. **Voltage Level Translator for F-RAM (U14):** The F-RAM operates at 3.3 V, while the PSoC 4000S can operate at 1.9 V, 3.3 V, 5 V or 3 V. This bidirectional level translator translates the I2C signals between the F-RAM and the PSoC 4000S.
13. **Cypress F-RAM (U11):** This kit features a Cypress F-RAM device (FM24V10-G) of 1 Mb capacity. The F-RAM is connected to the I2C interface of the PSoC 4000S. The F-RAM device can be used similar to an external EEPROM memory for data logging operations. Refer to [Using the FM24V10 F-RAM chapter on page 44](#) for details on using the F-RAM.
14. **RGB LED (LED5):** The onboard RGB LED can be controlled from the PSoC 4S00S.
15. **KitProg2 user button (SW3):** This button is used to switch between the KitProg2 modes. You can also use this button to provide input to the PSoC 5LP in custom applications. Note that the switch connects the PSoC 5LP pin to ground when pressed. Refer to the [KitProg2 User Guide](#) for more details.
16. **Rechargeable battery (V2):** This kit features an onboard rechargeable battery (ML2430-HS1) to power the kit at 3 V.
17. **User Button (SW2):** This button can be used to provide input to the PSoC 4000S. Note that the switch connects the PSoC 4000S pin to ground when pressed, so you need to configure the PSoC 4000S pin as resistive pull-up for detecting the switch press.
18. **Reset button (SW1):** This button is used to reset the PSoC 4000S and the EZ-BLE PRoC Module.
19. **Arduino ICSP compatible header (J12):** This kit features Arduino ICSP compatible header for SPI interface.
20. **EZ-BLE PRoC Module (U3):** The kit includes a Cypress EZ-BLE PRoC Module which can be used for custom applications.
21. **Potentiometer (R2):** This kit features a potentiometer which connects to an ADC input pin of the PSoC 4000S.
22. **VDD source selection switch (SW4):** This switch selects the power source for the kit, either USB connector/external power supply or battery.
23. **Current measurement selection switch (SW7):** This switch is used to measure the PSoC 4000S current consumption by turning off all the switches of SW7 and connecting an ammeter between VDD and P4.VDD test points. Refer to the [Current Measurement Switch chapter on page 39](#) for more details on how to measure the current.
24. **PSoC 4000S (U1):** This kit is designed to highlight the features of the PSoC 4000S device (CY8C4045AZI-S413).
25. **Programming target selection switch (SW5):** This switch selects the SWD lines between PSoC 4000S or EZ-BLE PRoC Module for programming and debugging.
26. **KitProg2 (PSoC 5LP) programmer and debugger (U15):** The PSoC 5LP device (CY8C5868LTI-LP039) serving as KitProg2, is a multi-functional system, which includes a programmer, debugger, USB-I2C bridge, and a USB-UART bridge. Refer to the [KitProg2 User Guide](#) for more details.
27. **FPC connector (J10):** This connects the Flex PCB to the main board.

See [Hardware Functional Description chapter on page 36](#) for details on various hardware blocks.

3.1.1 How to open the Kit Case

The kit comes with a case that houses an FR4 board called the PSoC 4 S-Series Pioneer board (main board) and a Flex PCB. The following steps show how to open the case.

1. Pull out the bottom casing by inserting the finger or a sharp edge object (e.g. a plectrum) in the notch provided, as shown in [Figure 3-6](#).

Note: Do not use your nails to remove the kit case.

Figure 3-6. Opening the bottom case



2. Remove the bottom case by gradually moving the finger along the edge of bottom case, as shown in [Figure 3-7](#).

Figure 3-7. Removing the bottom case



3. Hold the kit as shown in [Figure 3-8](#) and pull the bottom side of the casing wall outwards. Hold the USB connector and lift the board gently.

Figure 3-8. Pull out the main board from the case

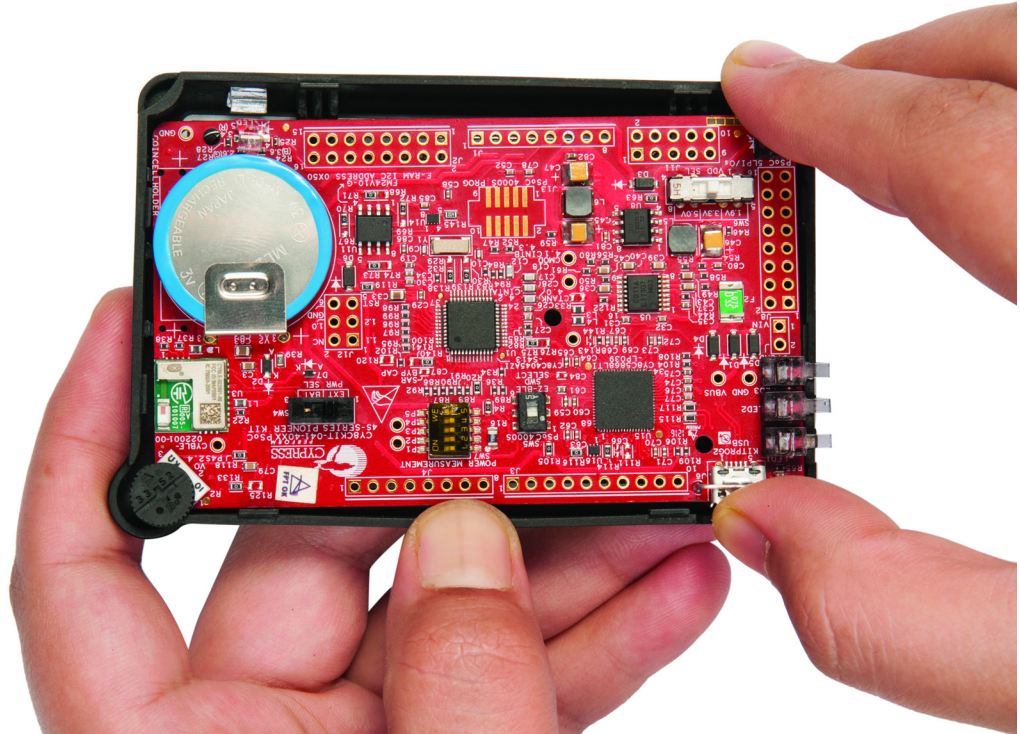

Note that the main board need to be removed slowly because it is connected to the Flex PCB. Flex PCB is permanently attached to the top case. Do not attempt to separate the Flex PCB from the top case. Instead, disconnect the Flex PCB from the main board by releasing the FPC connector, J10 (see [Figure 3-9](#)). The main board can be used for developing your own applications. Arduino shields can be plugged into the main board using press-fit connectors provided with the kit.

3.1.2 Disconnecting Flex PCB from main board

The FPC connector, J10, is used to connect Flex PCB to the main board. To disconnect the Flex PCB from the main board, flip up the latches of the FPC connector and pull out the Flex PCB. [Figure 3-9](#) below show the sequence of steps to be followed.

Figure 3-9. Disconnecting flex PCB from main board

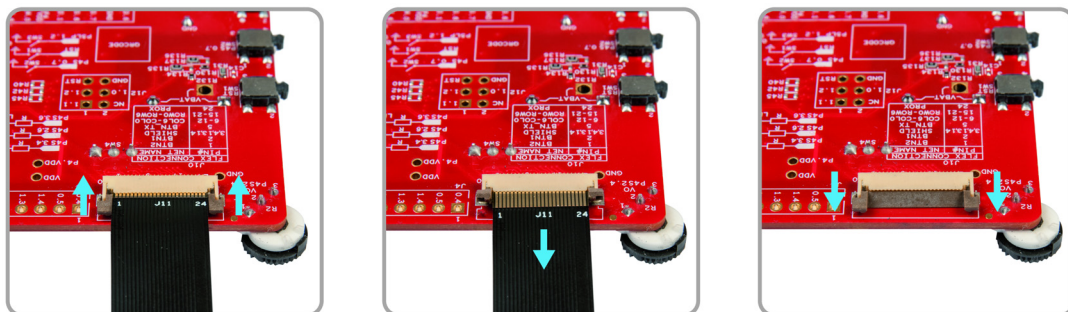

3.1.3 Reassembling Kit Case

1. Connect the flex PCB to the main board.
2. Flip the main board and gently push the flex PCB under the main board.
3. Align the main board switches with respective slots on the top case.
4. Push the main board switches into the slots gently.
5. At the other end of the main board, gently press the board until you hear the click sound.
Note: Make sure the onboard components or switch positions are not changed.
6. Hold the bottom case, align it to the potentiometer and Power Selection switch.
7. Press on all corners to close the bottom case.

3.1.4 Removing the Overlay

The kit case comes with an attached Overlay that is imprinted with a [CIE 1931 color gamut](#). This Overlay is intended to be used with [CE211584 Trackpad With Color Gamut](#) code example which is pre-programmed into the PSoC 4 S-Series Pioneer Kit. You can remove this Overlay if you are intend to use the trackpad without an Overlay. Following steps show how to remove the Overlay.

1. Hold the kit firmly and pull out the Overlay from the corner, as shown in [Figure 3-10](#). Use a sharp edge object (e.g. a plectrum or a credit card) to pull the overlay from the corner.
Note: Do not use your nails to remove the Overlay.

Figure 3-10. Removing the Overlay



2. Slowly lift the Overlay off the case.

After removing the Overlay, keep it in a dust-free place for durability of the micro-suction tape.

3.1.5 Attaching the Overlay

The Overlay has micro-suction tape on the bottom side that allows you to attach the Overlay to the kit, when required. Following steps show how to attach the Overlay:

1. Keep the kit on a flat surface. Align the top-left corner of the Overlay to the outline provided on the case, as shown in [Figure 3-11](#).

Figure 3-11. Attaching the Overlay

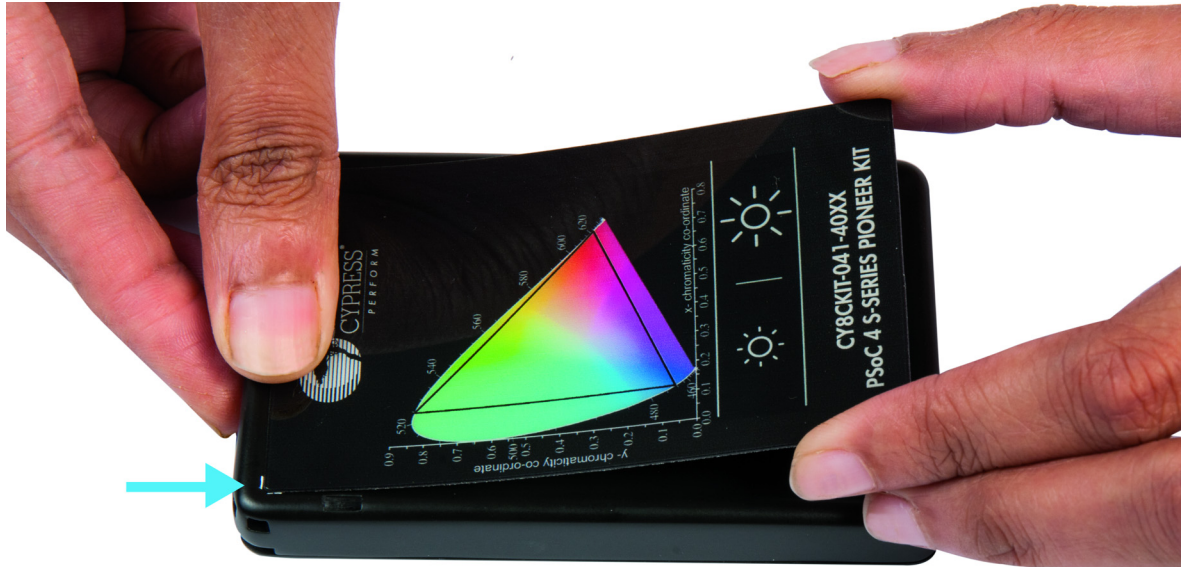

2. Place the top edge of the Overlay first and then slide your finger along the Overlay surface.

3.2 KitProg2

The PSoC 4 S-Series Pioneer Kit can be programmed and debugged using the onboard KitProg2. The KitProg2 is a multi-functional system, which includes a programmer, debugger, USB-I2C bridge, and a USB-UART bridge. The PSoC 4 S-Series Pioneer Kit also supports Mass Storage Programming using KitProg2. A Cypress PSoC 5LP device is used to implement KitProg2 functionality. The KitProg2 is integrated in most PSoC development kits. For more details on the KitProg2 functionality, refer to the *KitProg2 User Guide* available in the following path in kit installation directory:
`<Install_Directory>\CY8CKIT-041-40XX PSoC 4 S-Series Pioneer Kit\<version>\Documentation\KitProg2_User_Guide.pdf`

Before programming the device, ensure that PSoC Creator and PSoC Programmer software are installed on the computer. See the [Install Software chapter on page 17](#) for more information.

3.2.1 Programming and Debugging using PSoC Creator

Ensure switch SW5 is in the “PSoC 4000S” position to select the PSoC 4000S as the target device for programming. In the other position, the EZ-BLE PRoC Module on the kit can be programmed (see [Programming the EZ-BLE PRoC Module chapter on page 30](#)).

1. Connect the PSoC 4 S-Series Pioneer Kit to the PC using the USB cable, as shown in [Figure 3-12](#). The kit enumerates as a composite device if you are connecting it to your PC for the first time. The successful enumeration is indicated by the following status LEDs: Amber LED On,

Green LED Off and Red LED Off. If you do not see the desired LED status, refer to the [KitProg2 User Guide](#) for details on the KitProg2 status and troubleshooting instructions.

Figure 3-12. Connect USB Cable to USB connector on the kit



2. Open the desired project in PSoC Creator by selecting **File > Open > Project/Workspace**. This provides the option to browse and open your saved project.
3. Select **Build > Build Project** or pressing **[Shift] [F6]** to build the project.
4. If there are no errors during build, select **Debug > Program** or press **[Ctrl] [F5]**. This programs the device on the PSoC 4 S-Series Pioneer Kit.

The PSoC Creator has an integrated debugger. You can start the debugger by selecting **Debug > Debug** or by pressing **[F5]**. Refer to the **Debugging Using PSoC Creator** section in the [KitProg2 User Guide](#) for a detailed explanation on how to debug using PSoC Creator.

3.2.2 Programming using PSoC Programmer

PSoC Programmer (3.25 or later) can be used to program existing *.hex* files into the PSoC 4 S-Series Pioneer Kit. Refer to the **Programming Using PSoC Programmer** section in the [KitProg2 User Guide](#) for a detailed explanation on how to program using PSoC Programmer.

The KitProg2 firmware normally does not require any update. If necessary, you can use the PSoC Programmer software to update the KitProg2 firmware. Refer the **Updating the KitProg2 Firmware** section in the [KitProg2 User Guide](#) for a detailed explanation on how to update the KitProg2 firmware.

3.2.3 Programming the EZ-BLE PSoC Module

For programming the EZ-BLE PSoC Module, follow the instructions provided in [Programming and Debugging using PSoC Creator chapter on page 29](#). The only exception is to set the switch SW5 to the “EZ-BLE” position to select the EZ-BLE PSoC Module as the target device for programming.

3.2.4 Mass Storage Programmer

The KitProg2 in the PSoC 4 S-Series Pioneer Kit supports programming through a USB Mass Storage interface. This interface allows you to program the PSoC 4000S by copying `.hex` files into an emulated USB Mass Storage device. For more details on KitProg2 Mass Storage Programmer, refer to the [KitProg2 User Guide](#).

3.2.5 USB-UART Bridge

The KitProg2 on the PSoC 4 S-Series Pioneer Kit can act as a USB-UART bridge. The UART lines between the PSoC 4000S and the KitProg2 are hard-wired on the board, with UART_RX assigned to **P0[4]** and UART_TX assigned to **P0[5]** on PSoC 4000S. For more details on the KitProg2 USB-UART functionality, refer to the [KitProg2 User Guide](#).

Figure 3-13. UART connection between KitProg2 and PSoC4000S

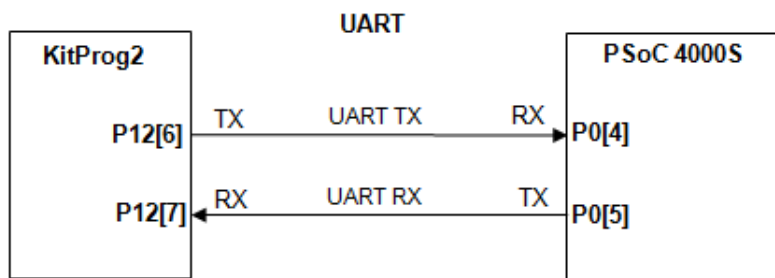

3.2.6 USB-I2C Bridge

The KitProg2 can function as a USB-I2C bridge and communicate with the Bridge Control Panel (BCP) software. The I2C lines on PSoC 4000S device are **P3[1] (SDA)** and **P3[0] (SCL)**, which are hard-wired on the board to the I2C lines of the KitProg2. The USB-I2C supports I2C speeds of 50 kHz, 100 kHz, 400 kHz, and 1 MHz. For more details on the KitProg2 USB-I2C functionality, refer to the [KitProg2 User Guide](#).

Figure 3-14. I2C connection between KitProg2 and PSoC4000S

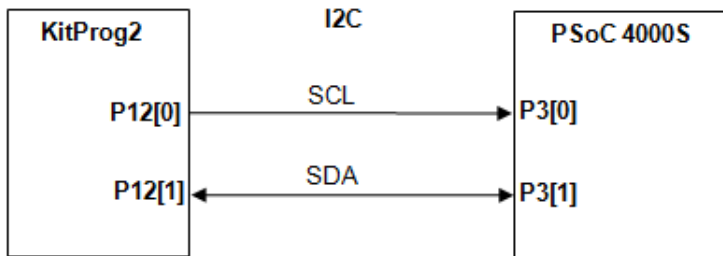

4. Code Examples



The PSoC 4 S-Series Pioneer Kit includes five code examples. To access the code examples, download and install the PSoC 4 S-Series Pioneer Kit setup file from www.cypress.com/CY8CKIT-041. After installation, the code examples will be available from **Examples and Kits > Kits** under PSoC Creator Start Page.

For more code examples, visit the [PSoC 3, PSoC 4, and PSoC 5 code examples](#) page, which lists all PSoC Creator code examples available across application notes, kits, and PSoC Creator.

4.1 Using the Kit Code Examples

Follow these steps to open and use the code examples.

1. Launch PSoC Creator from **Start > All Programs > Cypress > PSoC Creator <version> > PSoC Creator <version>**.
2. On the Start Page, click **CY8CKIT-041-40XX** under **Examples and Kits > Kits**. A list of code examples appears, as shown in [Figure 4-1](#).
3. Click on the desired code example, select a location to save the project and click **OK**.

Figure 4-1. Open Code Example from PSoC Creator

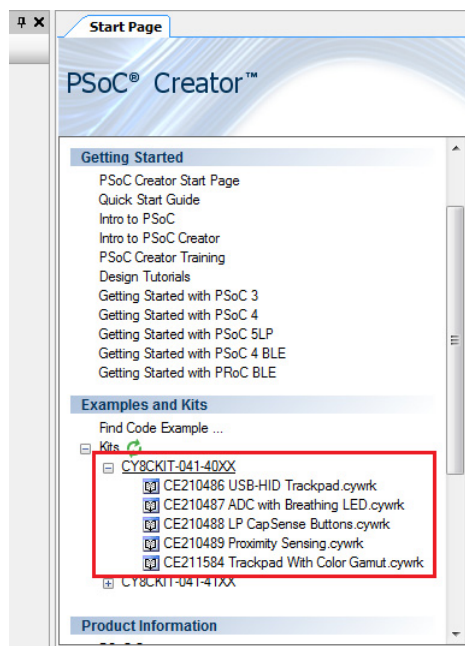

4. Build the code example by choosing **Build > Build <Project Name>**. After the build process is successful, a **.hex** file is generated.

5. Connect PSoC 4 S-Series Pioneer Kit to the PC using the USB cable, as shown in [Figure 3-12](#), to program the kit with the code example.
6. Choose **Debug > Program** in PSoC Creator.
7. If the device is already acquired, programming will complete automatically – the result will appear in the PSoC Creator status bar at the bottom left side of the screen. If the device is yet to be acquired, the Select Debug Target window will appear. Select **KitProg2/<serial_number>** and click the **Port Acquire** button, as shown in [Figure 4-2](#).

Figure 4-2. Port Acquire

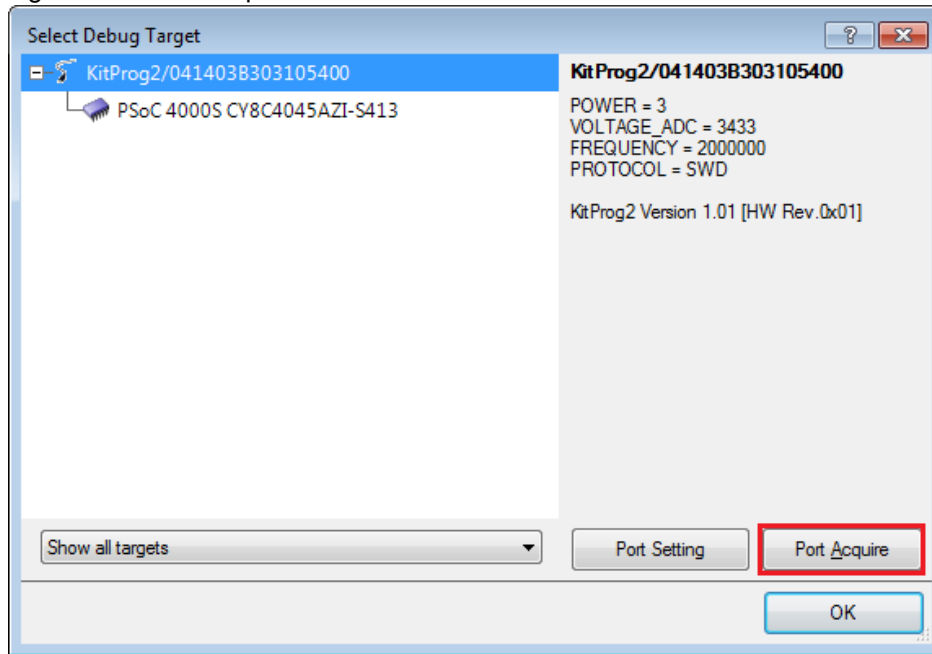

8. After the device is acquired, it is shown in a tree structure below the **KitProg2/<serial_number>**. Click the **Connect** button and then **OK** to exit the window and start programming, as shown in [Figure 4-3](#).

Figure 4-3. Connect Device from PSoC Creator and Program

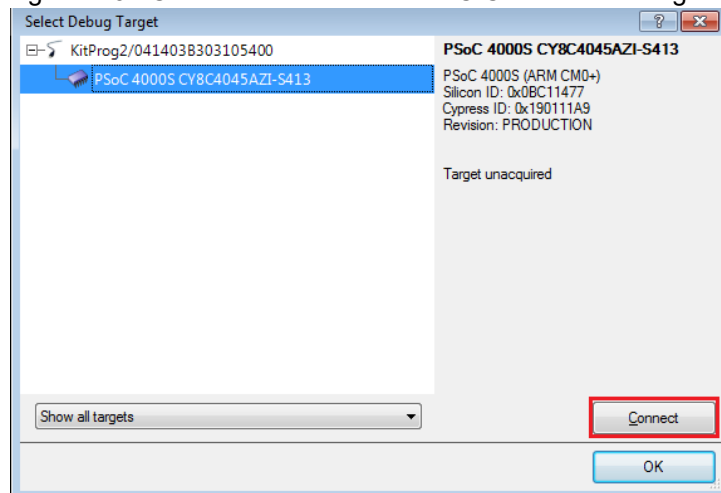

9. After programming is successful, the code example is ready to use.

4.2 Code Examples

Table 4-1 shows a list of code examples that can be used with this kit.

Table 4-1. Code Examples in PSoC Creator

| # | Project | Title/Description |
|---|--|--|
| 1 | CE210487 ADC with Breathing LED | This code example demonstrates the use of the CapSense_ADC component to measure an input voltage on an I/O pin. The example also shows how to implement a breathing LED using the Smart IO component. The breathing LED effect is implemented by XORing two PWM signals which have slightly different frequencies. There are four levels of breathing rate and three different color LEDs used. Depending on the ADC result, a specific LED and breathing rate is chosen. In addition to controlling the LEDs, the ADC result is sent over I2C to a host PC running Cypress's Bridge Control Panel (BCP) software. |
| 2 | CE210488 LP CapSense Buttons | This code example implements two CapSense buttons using the CY8CKIT-041-40XX. The left button is used to control the onboard RGB LED color and the right button is used to control the brightness of the RGB LED. Using the low power modes available in the PSoC 4 S-Series device, an average current of 5 μ A per button is achieved when the touch is not detected. |
| 3 | CE210489 Proximity Sensing | This code example demonstrates CapSense based proximity sensing using a PCB trace as a proximity sensor. A Proximity-sensing distance of 5 cm is achieved using a rectangular loop sensor with a 9 cm diagonal. The proximity detection is indicated by controlling the brightness of an LED. The LED has a minimum brightness when the hand is at a distance of 5 cm and gradually increases as the hand approaches the sensor. Using the low power modes available in the PSoC 4 S-Series device, an average current of 25 μ A is achieved while detecting the proximity of a hand at 5 cm. |
| 4 | CE211584 Trackpad With Color Gamut | This code example implements a CapSense based trackpad as a user interface. The trackpad has the CIE 1931 color gamut imprinted; user inputs (touch coordinates) are converted to the corresponding color coordinates. The RGB LED on the board is used to illustrate the chosen color by modulating the associated signal densities. The brightness of the RGB LED is controlled by using the two CapSense buttons. |
| 5 | CE210486 USB-HID Trackpad | This code example implements a CapSense trackpad and two button sensors using a PSoC 4000S device. The PSoC device is interfaced to a Windows PC as a mouse using the USB HID protocol. The trackpad controls the cursor on the PC and the two button sensors act as right-click and left-click buttons. To optimize device power consumption and provide optimum touch response, this code example implements two power modes: Fast Scan Mode and Slow Scan Mode. |

All code examples have an associated PDF document containing the project details, which can be accessed from the PSoC Creator as shown in the [Figure 4-4](#). Please refer to the respective code example document for more details on the functionality and implementation.

Figure 4-4. Code Example Document in PSoC Creator

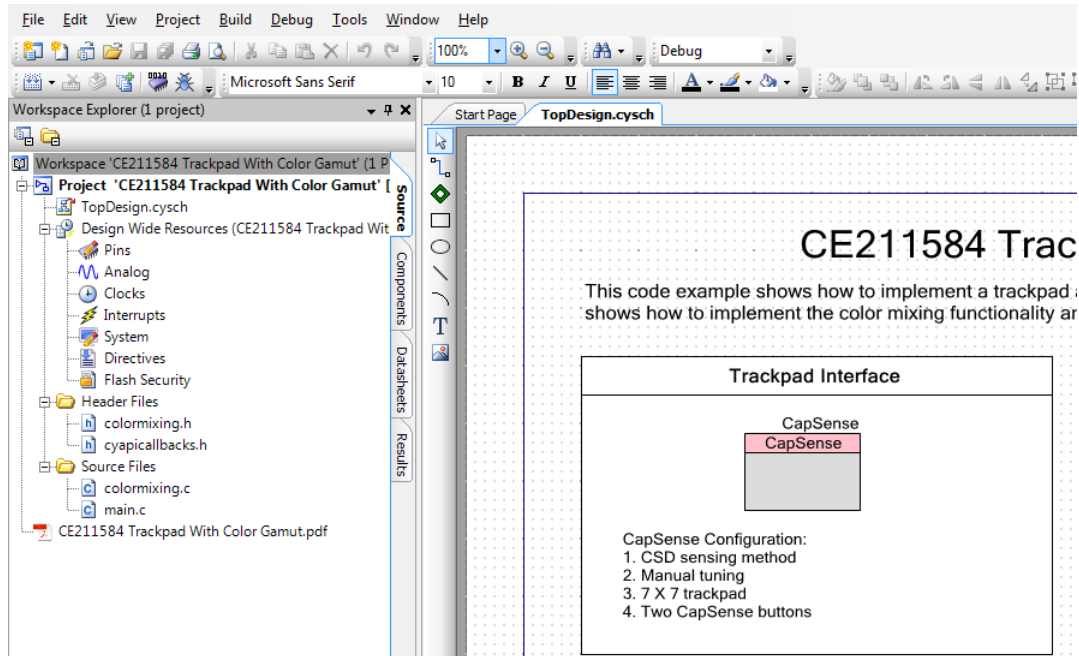

A. Appendix



A.1 Schematics

Refer to the schematics files available in the kit installation directory under following paths:

- `<Install_Directory>\CY8CKIT-041-40XX PSoC 4 S-Series Pioneer Kit\<version>\Hardware\CY8CKIT-041-40XX Schematic.pdf`
- `<Install_Directory>\CY8CKIT-041-40XX PSoC 4 S-Series Pioneer Kit\<version>\Hardware\CY8CKIT-041-40XX Flex Schematic.pdf`

A.2 Hardware Functional Description

This section provides detailed explanation on individual hardware blocks of the PSoC 4 S-Series Pioneer Kit.

A.2.1 PSoC 4000S (U1)

This kit features a PSoC 4000S (CY8C4045AZI-S413) family device. PSoC 4000S is a scalable and reconfigurable platform architecture for a family of programmable embedded system controllers with an ARM Cortex-M0+ CPU. The PSoC 4000S device family, based on this platform architecture, is a combination of a microcontroller with Programmable Analog Blocks, Programmable Digital Blocks, Programmable Interconnect and Routing, CapSense, standard communication and timing peripherals.

For more information, refer to the [PSoC 4000S web page](#) and the [PSoC 4000S Family Datasheet](#).

A.2.2 PSoC 5LP (U15)

An onboard PSoC 5LP (CY8C5868LTI-LP039) is used as KitProg2 to program and debug PSoC 4000S. The PSoC 5LP connects to the USB port of a PC through a USB connector and to the SWD and other communication interfaces of the PSoC 4000S device. The PSoC 5LP is a true system-level solution providing MCU, memory, analog and digital peripheral functions in a single chip. The CY8C58LPxx family offers a modern method of signal acquisition, signal processing, and control with high accuracy, high bandwidth, and high flexibility. Analog capability spans the range from thermocouples (near DC voltages) to ultrasonic signals.

For more information, visit the [PSoC 5LP web page](#). Also, refer to the [CY8C58LPxx Family Datasheet](#).

A.2.3 Serial Interconnection between PSoC 5LP and PSoC 4000S

In addition to use as an onboard programmer, the PSoC 5LP is used as a USB-Serial interface for the USB-UART bridge and USB-I2C bridge, as shown in [Figure A-1](#). The I2C bus contains firmware-controlled resistive pull-ups using FETs, which can be enabled or disabled using the PSoC 5LP pins. The USB-Serial pins of the PSoC 5LP are also connected to the I2C/UART pins of the PSoC 4000S that are available on the Arduino-compatible I/O headers; therefore, the PSoC 5LP can be used to control Arduino shields with an SPI/I2C/UART interface.

Note: The KitProg2 does not support USB-SPI bridge functionality. The SPI pins of the PSoC 4000S are connected to the PSoC 5LP for enabling SPI communication between PSoC 5LP and PSoC 4000S for custom PSoC 5LP applications.

Figure A-1. Schematics of Serial Interface Connections and I2C Pull-Up via FETs

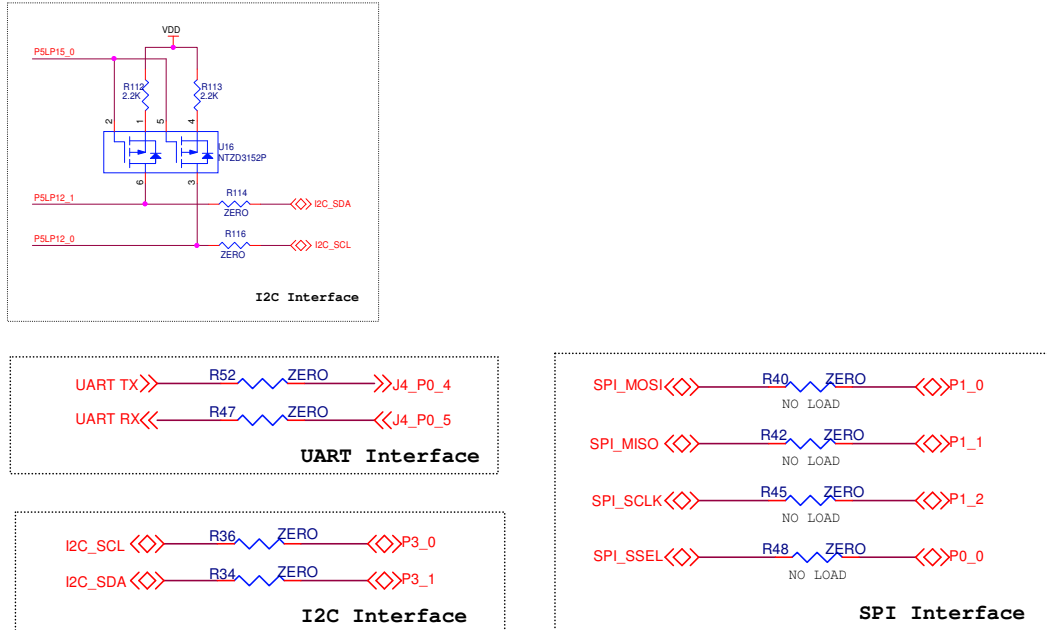

A.2.4 Power Supply System

The power supply system on this board is versatile, allowing the input supply to come from the following sources:

- 5-V power from onboard USB connector
- 6-V to 12-V power from Arduino shield or from external power supply through VIN header (J7)
- 3-V from battery

The PSoC 4 S-Series Pioneer Kit is designed to support 1.9 V, 3.3 V or 5 V operation for PSoC 4000S and EZ-BLE PSoC Module, when powered from USB port or external power supply. The voltage selection is made through the switch SW6. The voltage regulator (MB39C011A) from Cypress has two channels and generates a constant 3.3 V on one channel, and 1.9 V on the other. The onboard rechargeable battery provides 3 V to the kit. The selection between battery and USB is made through the VDD source selection switch, SW4. When the kit is powered from the USB connector, it provides 3.3 V and 5 V to the Arduino-compatible power header. [Figure A-2](#) shows the schematics of the voltage regulator and power selection circuit.

Figure A-2. Schematics of Voltage Regulator Circuit and Power Selection Switch

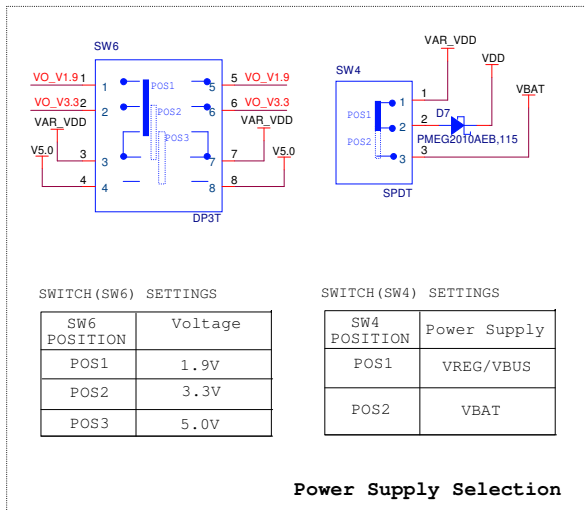
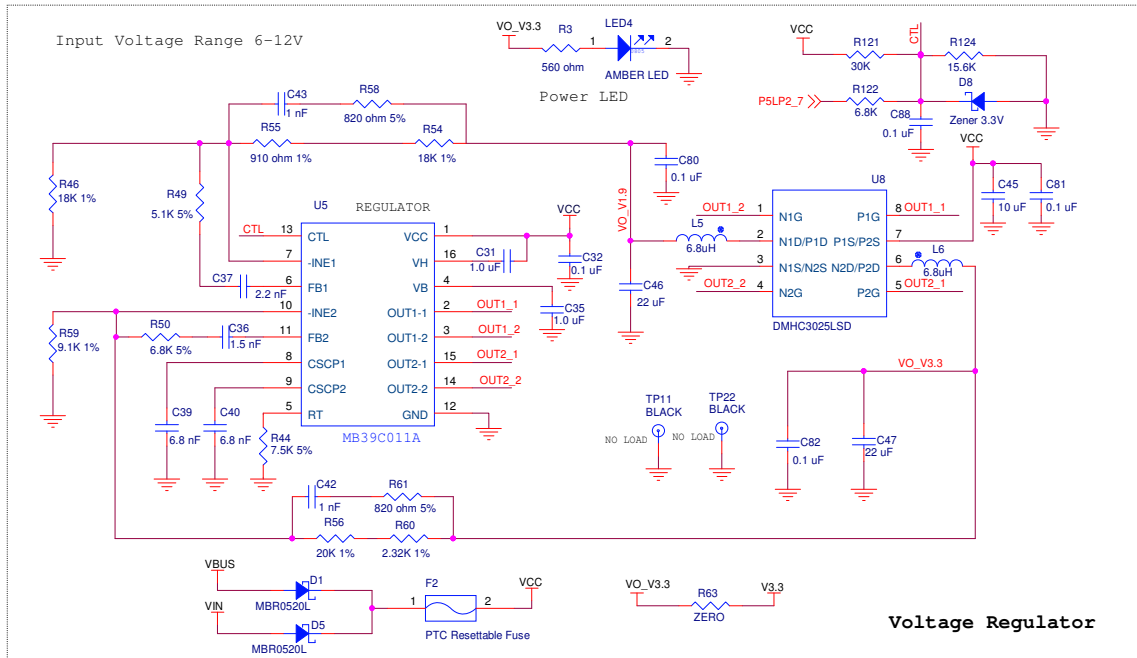

Note:

- PSoc pins should not be connected to overvoltage/reverse voltage more than what is mentioned in the datasheet
- PSoc pins should not be driven with currents more than what is mentioned in the datasheet.

A.2.5 Battery Charging Circuit

The 3.3 V generated by the regulator is also used to charge the battery as shown in Figure A-3. Note that the battery charging time is not optimal if the battery is discharged below 2.2 V (dead threshold). Please refer to the battery datasheet for details.

Figure A-3. Battery Charging Circuit

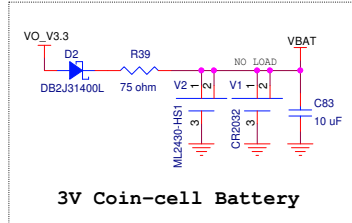

Note: Please consider the polarity marks provided on the board while re-soldering the battery.

A.2.6 Protection Circuits

The power supply rail has reverse-voltage, overvoltage, short circuit, and excess current protection features, as shown in Figure A-4. A PTC resettable fuse is connected to protect the computer's USB port from shorts and over current. ORing diodes prevent damage to components when the board is powered from different voltage sources at the same time. The ESD protection is provided for the USB connector.

Figure A-4. Power Supply Block Diagram with Protection Circuits

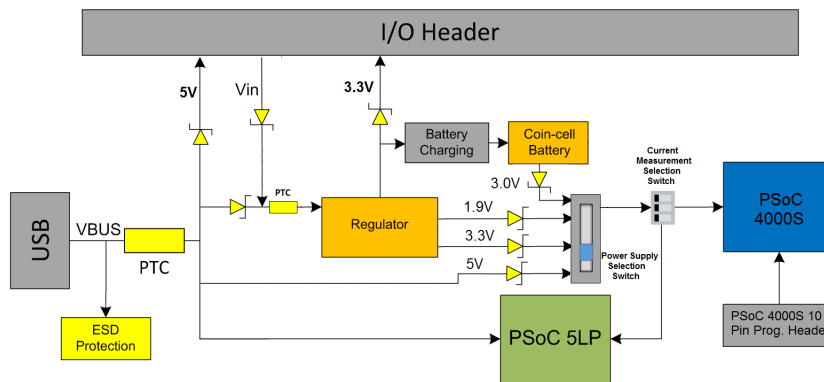

A.2.7 Current Measurement Switch

To measure the PSoc 4000S power consumption, the switch SW7 is populated in series with the power supply to the PSoc 4000S which can be used to measure current using an ammeter without the need to remove any components from the board. The KitProg2 on the board is also able to measure the power consumption of PSoc 4000S using its internal Del-Sig ADC and SAR ADC. For this purpose, either a 0.86 Ω shunt resistor or 9.76 Ω shunt resistor can be selected using the switch SW7. Note that the contact resistance of the switch is 150 m Ω . The effective shunt resistance achieved will be 1.01 Ω and 9.91 Ω respectively.

Figure A-5. Schematics of Current Measurement Switch

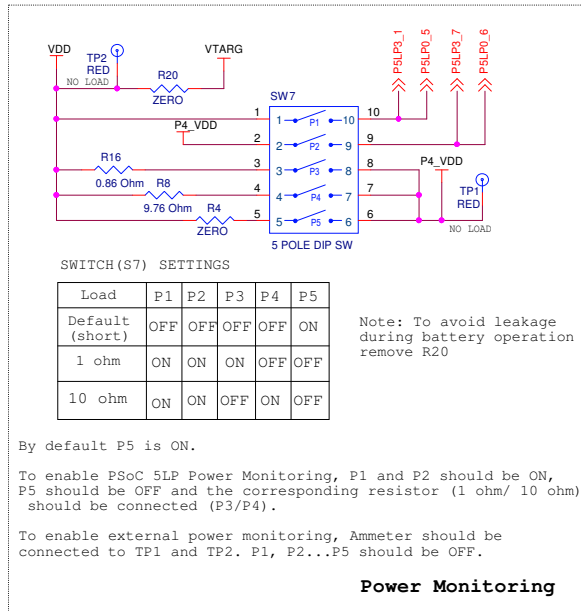

The following methods are supported for measuring the current consumption of the PSoC 4000S device.

- Measurement using ammeter when powered from USB connector or battery

When the board is powered through the USB connector or battery, turn off all the switches of SW7 and connect an ammeter between P4.VDD and VDD test points, as shown in [Figure A-6](#).

Figure A-6. Current Measurement when Powered from USB Connector or Battery

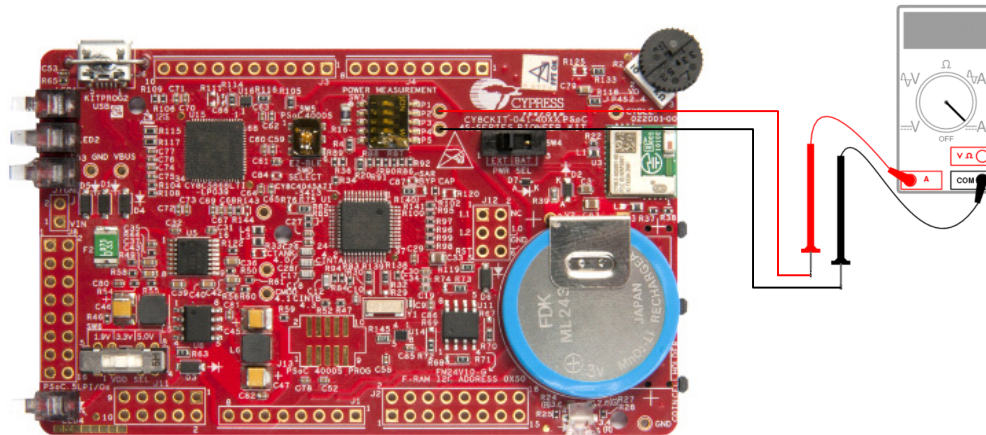

Note: While measuring the current consumption of PSoC 4000S device, remove R118 from the board in order to get accurate current measurement values.

Figure A-7. Potentiometer Schematics

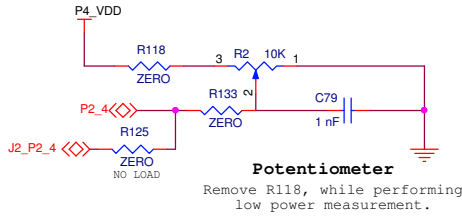

Note that there is a current leakage of 80 μ A on VTARG node into the PSoC 5LP when using battery (VBAT) as the power supply. Remove the resistor R20 to avoid the leakage and to get accurate current measurement values. You will not be able to program the PSoC 4000S while you have removed resistor. So it is recommended to populate the resistor R20 back once the measurement is done to enable programming of PSoC 4000S. After measuring the current consumption, move switch P5 of SW7 to ON position for normal operation of the kit. See [Figure A-5 on page 40](#) for other switch combinations of SW7.

■ Measurement using ammeter when powered from an external power supply

When the PSoC 4 S-Series Pioneer Kit is powered from an external power supply, remove the USB cable from J6. Connect the positive terminal of the external power supply to the positive terminal of the ammeter and the negative terminal of the ammeter to the P4.VDD test point. Connect the negative terminal of the external power supply to any GND pin on the board. [Figure A-8](#) shows the required connections.

Figure A-8. Current Measurement when Powered Externally

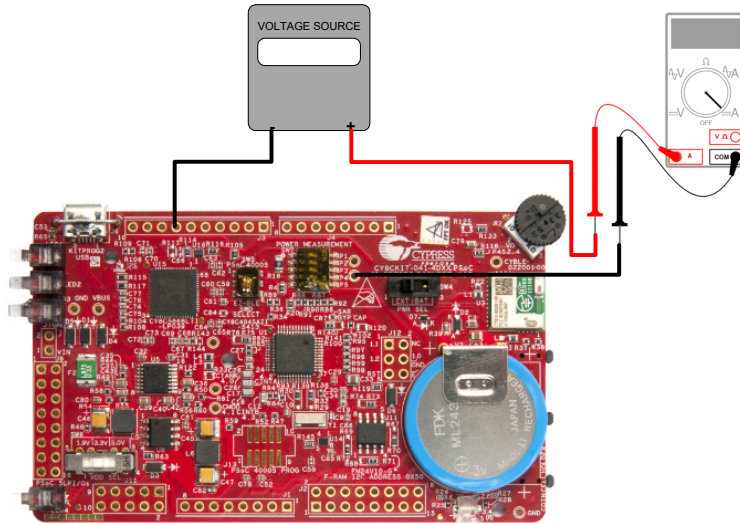

A.2.8 Expansion Connectors

A.2.8.1 Arduino-compatible Headers (J1, J2, J3, J4, and J12)

This kit has five Arduino-compatible headers: J1, J2, J3, J4, and J12. You can develop applications based on the Arduino shield's hardware.

The J1 header contains I/O pins for reset, internal reference voltage (IOREF), and power supply lines. The J2 header is an analog port that contains I/O pins for the SAR ADC. The J3 header is pri-

marily a digital port that contains I/O pins for PWM, I2C, SPI, and analog reference. The J4 header is also a digital port that contains I/O pins for UART and PWM. The J12 header is an Arduino ICSP compatible header for the SPI interface and is not populated. Most of the pins available on J2, J3 and J4 headers have multiplexed functionalities such as CapSense sensors, user switch or RGB LEDs. Refer to [Onboard Peripherals chapter on page 51](#) for details about onboard peripheral connections to the pins on these headers.

Note: Pin P1[7] has a provision to connect a 1.0 uF capacitor (C87) as a bypass capacitor for SAR ADC operation. This capacitor is not applicable for the PSoC 4000S device and is provided only for footprint compatibility with CY8CKIT-041-41XX.

A.2.8.2 *Additional Functionality of Header J2*

The J2 is a 8×2 header that supports Arduino shields. On the non-Arduino side of the header (even pins - Pin 2, 4, 6, and so on), some pins from port 0, port 1, port 3 and port 4 pins of PSoC 4000S are brought for general-purpose use.

A.2.8.3 *Functionality of Unpopulated Header J12*

The J12 is a 3×2 header that supports Arduino shields. This header is used on a small subset of shields and is not populated on the PSoC 4 S-Series Pioneer Kit.

A.2.8.4 *PSoC 5LP GPIO Header (J8)*

The J8 is a 8×2 header provided on the kit to bring out several pins of the PSoC 5LP to support advanced features such as a low-speed oscilloscope and a low-speed digital logic analyzer. This header also contains the USB-UART bridge pins and USB-I2C bridge pins that can be used when these pins are not accessible on the Arduino headers because a shield is connected. The additional PSoC 5LP pins are direct connections to the internal programmable analog logic of PSoC 5LP. This header also has GPIOs for custom application usage.

A.2.8.5 *KitProg2 Custom Application Header (J11)*

A 5×2 header is provided on the board to bring out more GPIOs of PSoC 5LP for custom application usage. This header also brings out the PSoC 5LP programming pins and can be programmed using [MiniProg3](#) and 5-pin programming connector.

A.2.9 USB Micro-B Connector

The PSoC 5LP connects to the USB port of a PC through a USB Micro-B connector, which can also be used to power the PSoC 4 S-Series Pioneer Kit. A resettable polyfuse is used to protect the computer's USB port from shorts and over current. If more than 500 mA is drawn from the USB Micro-B connector, the fuse will automatically break the connection until the short or overload is removed.

A.2.10 CapSense Circuit

The CapSense sensors such as trackpad, buttons and proximity sensors are on Flex PCB whereas CapSense components such as 560 Ω series resistors on sensor lines, CMOD and CTANK capacitors which are essential for CapSense with Self-Capacitance functionality, CintA and CintB capacitors which are essential for CapSense with Mutual-Capacitance functionality are on the main board. A 2.2-nF capacitor is present on the CMOD pin, P4[1], for CapSense operation. This kit also supports CapSense designs that enable waterproofing. On this kit, the hatch (Shield pattern) can be connected to the Shield pin, P3[5] or to ground by a three-pad 0Ω resistor (R75 and R76). By default, R75 is mounted on the kit, which connects the hatch to the Shield pin. This is required for liquid tolerance.

For details on using CapSense, design guidelines and capacitive sensing, refer to [AN85951 - PSoC 4 CapSense Design Guide](#).

A.2.10.1 *CapSense Trackpad*

The Flex PCB has a 14 element capacitive trackpad, which is connected to the PSoC 4000S pins.

This trackpad controls the LED color in [CE211584 Trackpad With Color Gamut](#) code example.

A.2.10.2 *CapSense Proximity Sensor*

The Flex PCB has one proximity sensor loop, which is connected to pin P1[6]. The proximity sensor loop in the PSoC 4 S-Series Pioneer Kit can also be used as a Guard sensor to make the sensors tolerant to streams of liquids.

This proximity sensor controls the LED brightness in [CE210489 Proximity Sensing](#) code example.

A.2.10.3 *CapSense Buttons*

The Flex PCB has two buttons, the left button (BTN1) is connected to pin P0[1] and the right button (BTN2) is connected to pin P0[2].

These buttons control the LED brightness in [CE211584 Trackpad With Color Gamut](#) code example.

A.2.11 LEDs

The PSoC 4 S-Series Pioneer Kit has five LEDs. Three status LEDs (Red, Amber and Green) indicate the status of the KitProg2. An amber LED indicates the status of power supplied to the kit. The kit also has a general-purpose RGB LED connected to PSoC 4000S for user applications.

A.2.12 Push Buttons

The PSoC 4 S-Series Pioneer Kit has a reset button (SW1) and two user buttons. The reset button is connected to the XRES pin of the PSoC 4000S and EZ-BLE PSoC Module, and is used to reset both the devices. One user button (SW2) is connected to P0 [7] of the PSoC 4000S device. The other user push button (SW3) is connected to P1 [2] of the PSoC 5LP. All the buttons connect to ground on activation (active low).

A.2.13 Cypress Ferroelectric RAM (F-RAM)

The PSoC 4 S-Series Pioneer Kit contains an F-RAM device ([FM24V10-G](#)) that can be accessed through I2C lines P3 [0] and P3 [1] of the PSoC 4000S. The F-RAM has a capacity of 1-Mbit (128 KB) with an I2C speed up to 3.4 MHz. The I2C slave address of the F-RAM device is 7 bits wide, and the two least significant bits are configurable through physical pins. These pins are hard-wired to 00 on the board. By default, the address of the F-RAM device used on the kit is 0x50. This address can be modified by changing the R68/R71 (A1) and R67/R70 (A2) resistor pairs. The operating voltage range of the F-RAM is between 2 V and 3.6 V. To prevent the F-RAM from operating at voltages greater than 3.6 V, the power supply to the F-RAM is derived from the output of the 3.3-V regulator. The I2C lines are connected to the 3.3 V side of the onboard level translator to allow the F-RAM to communicate with the PSoC 4000S operating at 5 V. For more information on using the F-RAM, refer to [Using the FM24V10 F-RAM chapter on page 44](#).

A.2.14 EZ-BLE PSoC module

The PSoC 4 S-Series Pioneer Kit includes an [EZ-BLE PSoC Module](#). The EZ-BLE PSoC Module is a fully integrated, 10×10×1.8 mm, fully certified, programmable module designed for ease-of-use and reduced time-to-market. It contains Cypress's PSoC BLE device, two crystals, chip antenna, shield, and passive components. For more information on using the EZ-BLE PSoC module, see

Using EZ-BLE PSoC Module chapter on page 46.

A.2.15 External Crystals

The PSoC 4 S-Series Pioneer Kit includes a 32.768 kHz (Y1) external crystal for the WCO input. The WCO is used to provide an accurate low-frequency clock to PSoC 4000S for Deep Sleep wake up intervals, and WDT reset intervals.

A.3 Using the FM24V10 F-RAM

The PSoC 4 S-Series Pioneer Kit has an onboard Ferroelectric RAM (F-RAM) chip that can hold up to 1 Mb of data. The chip provides an I2C communication interface for data access. It is hard-wired to the I2C interface (P3[0] and P3[1] of the PSoC 4000S); the same lines are routed to the KitProg2 I2C interface. Because the F-RAM device is an I2C slave, it can be accessed or shared among various I2C masters on the same lines. For more details on the F-RAM device, refer to the device [data-sheet](#).

A.3.1 Address Selection

The slave address of the F-RAM device consists of three parts, as shown in [Figure A-9](#): slave ID, device select, and page select. Slave ID is an F-RAM family-specific ID provided in the datasheet of the particular F-RAM device. For the device used on the PSoC 4 S-Series Pioneer Kit (FM24V10-G), the slave ID is 1010b. Device select bits are set using the two physical pins A2 and A1 in the device. The setting of these two pins in PSoC 4 S-Series Pioneer Kit is controlled by resistors R68/R71 (A1) and R67/R70 (A2). Because the memory location in F-RAM is divided into two pages of 64 KB each, the page select bit is used to refer to one of the two pages in which the read or write operations will take place.

Note: The 8-pin SOIC footprint provided for the F-RAM FM24V10 on the PSoC 4 S-Series Pioneer Kit is compatible with all I2C-based F-RAM devices from Cypress (FM24Vxx, FM24CLxx, and CY15BxxxJ parts). The F-RAM parts with more than 64 KB size support only four addresses (four devices of the same type on the same I2C bus); resistors connected to A1 (R68/R71) and A2 (R67/R70) pins can be used to select any of the four addresses. The F-RAM parts with less than 64 KB and FM24CLxx parts support eight addresses; resistors connected to A0 (R69/R72), A1 (R68/R71) and A2 (R67/R70) pins can be used to select one of the eight addresses.

Figure A-9. F-RAM I2C Address Byte Structure

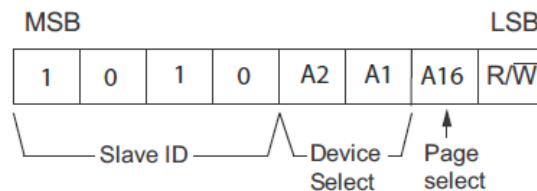

A.3.2 High Speed Mode (Hs-mode)

The FM24V10 supports a 3.4 MHz high-speed mode. A master code (00001XXXb) must be issued to place the device into high-speed mode. Communication between master and slave will then be enabled for speeds up to 3.4 MHz. A STOP condition will exit Hs-mode. Single-byte and multiple-byte reads and writes are supported.

Figure A-10. F-RAM I2C Data Format for HS Mode

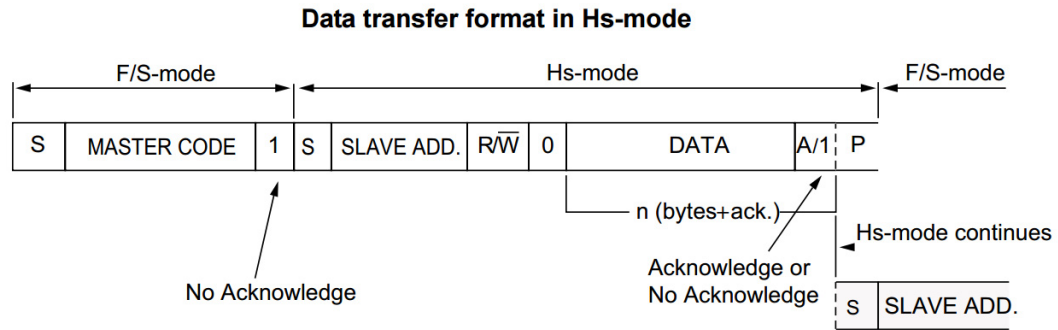

A.3.3 Write/Read Operation

The F-RAM device datasheet includes details on how to perform a write/read operation with the F-RAM. [Figure A-11](#) and [Figure A-12](#) provide a snapshot of the write/read packet structure as a quick reference.

Figure A-11. F-RAM Single-Byte and Multiple-Byte Write Packet Structure

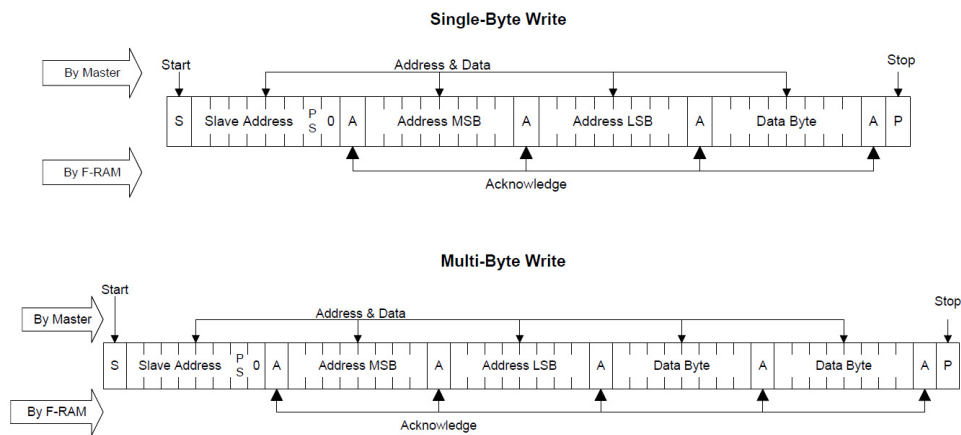
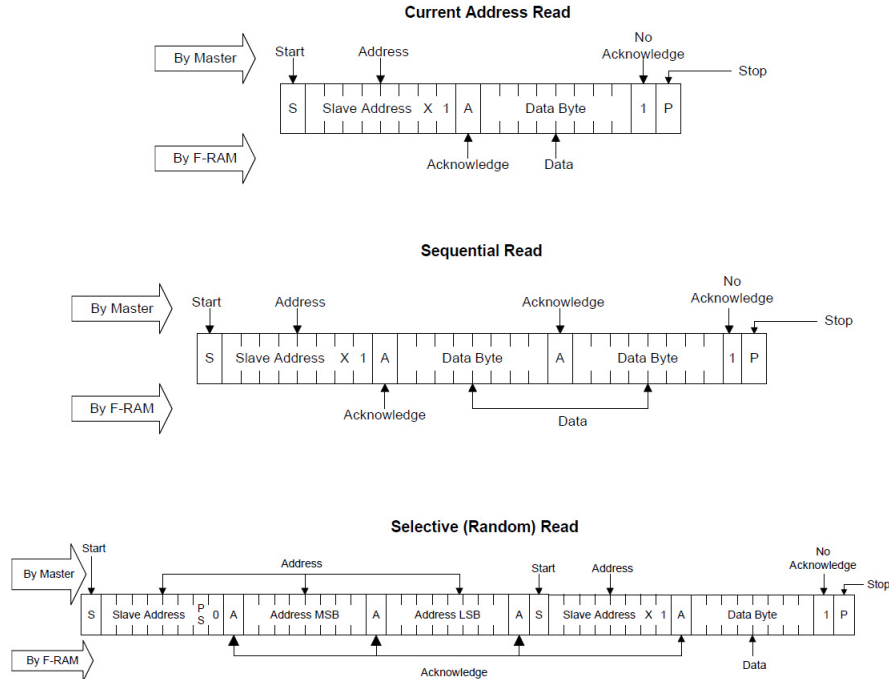

Figure A-12. F-RAM Single-Byte and Multiple-Byte Read Packet Structure



As the figures show, operations start with the slave address followed by the memory address. For write operations, the bus master sends the slave address and memory address followed by one or more data bytes. Each byte of data is written to consecutive locations in the memory, and the memory generates an acknowledgement condition.

For 'Current Address Read' and 'Sequential Read', the bus master sends only the slave address. The memory address used is the same address that was set by the previous 'Write' or 'Selective Read' operation. For 'Selective Read' operations, after receiving the complete slave address and memory address, the memory will begin shifting data from the current address on the next clock

Note: You can communicate with the F-RAM using the Bridge Control Panel (BCP) software similar to the way you communicate with any other I2C slave device. Refer to the [KitProg2 User Guide](#) for more details on how to use the BCP to communicate with an I2C slave device. Visit the [CY15FRAMKIT-001 Serial F-RAM Development Kit webpage](#) for code examples and the Arduino library for interfacing I2C F-RAM devices with the PSoC 4 family. Please note that PSoC 4 S-Series Pioneer Kit needs to be power cycled when the F-RAM I2C is stuck. F-RAM I2C will be stuck if the PSoC 4000S device is reset while it is communicating with the F-RAM.

A.4 Using EZ-BLE PProC Module

To get started with the EZ-BLE PProC module, refer to the application note [AN96841 - Getting Started With EZ-BLE PProC Module](#). This application note introduces you to Cypress's EZ-BLE family of Bluetooth Smart modules, helps you explore the EZ-BLE module architecture and development tools and shows you how to create your first project with the EZ-BLE PProC Module and PSoC Creator, the development tool used for all EZ-BLE modules. This application note also guides you to more resources to accelerate in-depth learning about the Cypress EZ-BLE solutions. Visit www.cypress.com/ez-bleprocmodule/ for additional information on the EZ-BLE PProC Module.

The EZ-BLE PProC module includes the following connections to the PSoC 4000S and KitProg2:

- I²C connections to KitProg2 and PSoC 4000S. See [Table A-1](#) for details.
- SWD connections to KitProg2 through the switch SW5. The SWD connections are shared between the PSoC 4000S and EZ-BLE PSoC Module.

The connections between EZ-BLE PSoC Module and PSoC 4000S are shown in [Figure A-13](#)

Figure A-13. EZ-BLE PSoC Connections

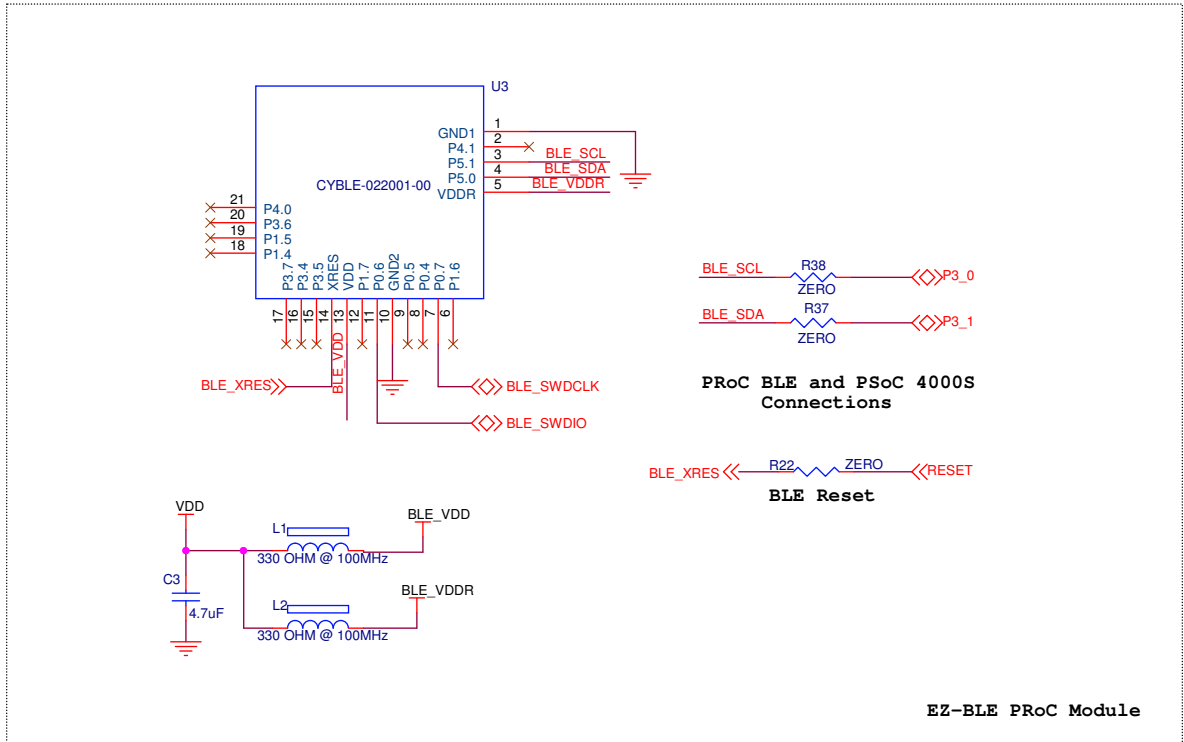

Table A-1. EZ-BLE PSoC Connections

| EZ-BLE PSoC Module Connections | | | |
|--------------------------------|--------|----------------|--------------|
| EZ-BLE | PSoC 4 | KitProg2 | Description |
| BLE_SDA, P5.0 | P3.1 | I2C_SDA, P12.1 | GPIO/I2C_SDA |
| BLE_SCL, P5.1 | P3.0 | I2C_SCL, P12.0 | GPIO/I2C_SCL |
| BLE_SWDIO, P0.6 | – | SWDIO, P12.2 | SWD I/O |
| BLE_SWCLK, P0.7 | – | SWDCLK, P12.3 | SWD Clock |

To program the EZ-BLE PSoC Module using KitProg2, follow the instructions provided in [Programming the EZ-BLE PSoC Module](#) chapter on page 30.

A.5 Migrating Projects Across Different Pioneer Series Kits

All Cypress Pioneer series kits are Arduino Uno compatible and have some common onboard peripherals such as RGB LED, CapSense and User Switch. However, the pin mapping in each of the boards is different due to differences in pin functions of the PSoC device used. This section lists the pin mapping of the Pioneer series kits to allow for easy migration of projects across different kits.

In some cases, the pins available on the Pioneer kit headers are a superset of the standard Arduino Uno pins. For example, J2 contains only one row of pins on the Arduino Uno pin layout while it contains 2 rows of pins on many of the Pioneer series kits.

Figure A-14. Pioneer series kits pin map

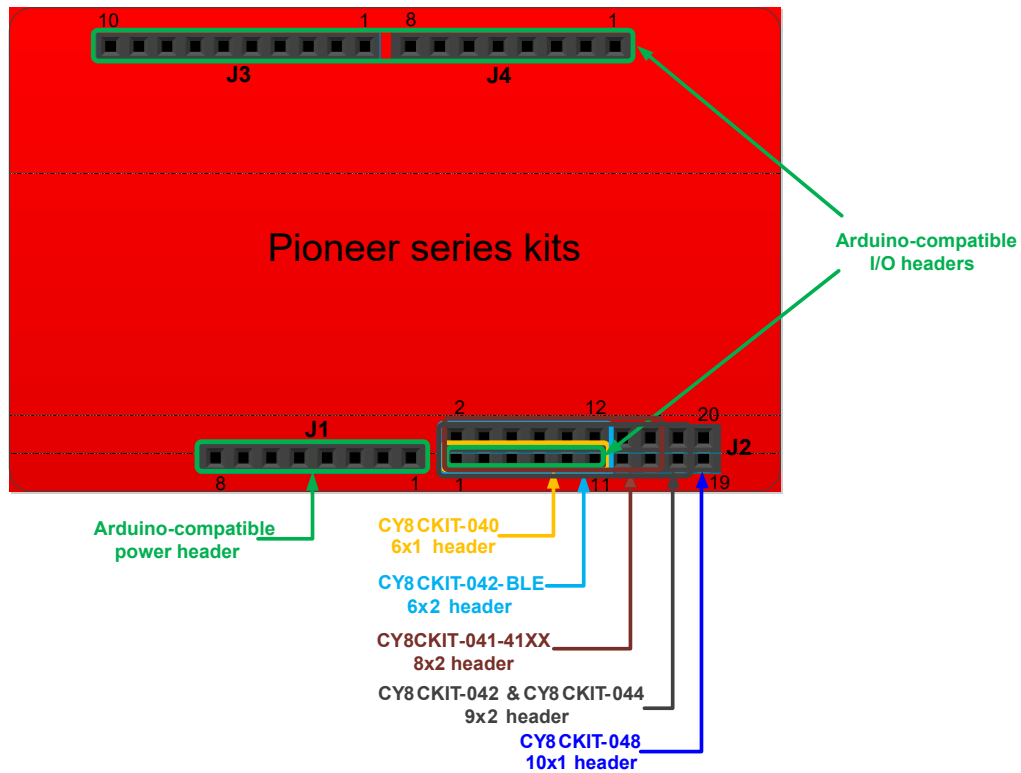

A.5.1 Arduino Uno Compatible Headers

Table A-2. J1 Arduino Compatible Header Pin Map

| # | Arduino Pin | Pioneer Series Kits | | | | | | |
|---|-------------|---------------------|-------------|-----------------|-------------|-------------|---------------------------------------|-------------|
| | | CY8CKIT-042 | CY8CKIT-040 | CY8CKIT-042-BLE | CY8CKIT-044 | CY8CKIT-046 | CY8CKIT-041-40XX/ CY8CKIT-041-41XX | CY8CKIT-048 |
| 1 | VIN | VIN | VIN | VIN | VIN | VIN | VIN | VIN |
| 2 | GND | GND | GND | GND | GND | GND | GND | GND |
| 3 | GND | GND | GND | GND | GND | GND | GND | GND |
| 4 | 5V | V5.0 | V5.0 | V5.0 | V5.0 | V5.0 | V5.0 | V5.0 |
| 5 | 3.3V | V3.3 | V3.3 | V3.3 | V3.3 | V3.3 | V3.3 | V3.3 |
| 6 | RESET | RESET | RESET | RESET | RESET | RESET | RESET | RESET |
| 7 | IOREF | P4.VDD | P4.VDD | BLE.VDD | P4.VDD | P4L.VDD | P4.VDD | PAC.VDD |
| 8 | NC | NC | NC | NC | NC | NC | NC | NC |

Table A-3. J2 Arduino Compatible Header Pin Map

| # | Arduino Pin | Pioneer Series Kits | | | | | | |
|----|-------------|---------------------|--------------------|--------------------|--------------------|--------------------|---------------------------------------|--------------------|
| | | CY8CKIT-042 | CY8CKIT-040 | CY8CKIT-042-BLE | CY8CKIT-044 | CY8CKIT-046 | CY8CKIT-041-40XX/ CY8CKIT-041-41XX | CY8CKIT-048 |
| 1 | A0 | P2[0] | P0[0] | P3[0] | P2[0] | P2[0] | P2[0] ¹ | P3[0] |
| 2 | — | P0[2] ¹ | — | P2[0] | P2[6] ¹ | P3[6] ¹ | P1[6] ¹ | — |
| 3 | A1 | P2[1] | P0[1] | P3[1] | P2[1] | P2[1] | P2[1] ¹ | P3[1] |
| 4 | — | P0[3] ¹ | — | P2[1] ¹ | P6[5] ¹ | P3[7] ¹ | P4[0] ¹ | — |
| 5 | A2 | P2[2] | P0[2] ¹ | P3[2] | P2[2] | P2[2] | P2[2] ¹ | P3[2] |
| 6 | — | P4.VDD | — | P2[2] ¹ | P0[6] ¹ | P9[0] | P4.VDD | — |
| 7 | A3 | P2[3] | P0[4] ¹ | P3[3] | P2[3] | P2[3] | P2[3] ¹ | P3[3] |
| 8 | — | P1[5] ¹ | — | P2[3] ¹ | P4[4] ¹ | P9[1] | P0[1] ¹ | — |
| 9 | A4 | P2[4] | P1[3] | P3[4] | P2[4] | P2[4] | P2[4] ¹ | P3[4] ¹ |
| 10 | — | P1[4] ¹ | — | P2[4] ¹ | P4[5] ¹ | P9[2] | P0[6] ¹ | — |
| 11 | A5 | P2[5] | P1[2] | P3[5] | P2[5] | P2[5] | P2[5] | P3[7] ¹ |
| 12 | — | P1[3] ¹ | — | P2[5] ¹ | P4[6] ¹ | P9[3] | P0[7] ¹ | — |
| 13 | — | P0[0] | — | — | P0[0] | — | P2[6] ¹ | P2[6] ¹ |
| 14 | — | GND | — | — | GND | — | GND | — |
| 15 | — | P0[1] | — | — | P0[1] | — | P3[4] ¹ | P2[5] ¹ |
| 16 | — | P1[2] ¹ | — | — | P3[4] ¹ | — | P3[6] ¹ | — |
| 17 | — | P1[0] | — | — | P0[7] ¹ | — | — | P2[1] ¹ |
| 18 | — | P1[1] ¹ | — | — | P3[5] ¹ | — | — | — |
| 19 | — | — | — | — | — | — | — | P3[5] ¹ |
| 20 | — | — | — | — | — | — | — | — |

Note 1: These pins are also used for onboard peripherals. Refer to the tables in the [A.5.2 Onboard Peripherals](#) section for connection details.

Table A-4. J3 Arduino Compatible Header Pin Map

| # | Arduino Pin | Pioneer Series Kits | | | | | | |
|----|-------------|---------------------|--------------------|-----------------|-------------|-------------|---------------------------------------|--------------------|
| | | CY8CKIT-042 | CY8CKIT-040 | CY8CKIT-042-BLE | CY8CKIT-044 | CY8CKIT-046 | CY8CKIT-041-40XX/ CY8CKIT-041-41XX | CY8CKIT-048 |
| 1 | D8 | P2[6] | P1[4] | P0[5] | P0[2] | P0[2] | P0[3] ¹ | P2[4] ¹ |
| 2 | D9 | P3[6] | P1[5] | P0[4] | P0[3] | P0[3] | P2[7] | P1[7] ¹ |
| 3 | D10 | P3[4] | P1[6] | P0[2] | P2[7] | P6[3] | P0[0] ¹ | P0[7] |
| 4 | D11 | P3[0] | P1[1] ¹ | P0[0] | P6[0] | P6[0] | P1[0] ¹ | P0[4] |
| 5 | D12 | P3[1] | P3[1] | P0[1] | P6[1] | P6[1] | P1[1] ¹ | P0[5] |
| 6 | D13 | P0[6] | P1[7] | P0[3] | P6[2] | P6[2] | P1[2] ¹ | P0[6] |
| 7 | GND | GND | GND | GND | GND | GND | GND | GND |
| 8 | AREF | P1[7] | NC | VREF | P1[7] | VREF | P1[7] ¹ | P1[3] ¹ |
| 9 | SDA | P4[1] | P1[3] | P3[4] | P4[1] | P4[1] | P3[1] | P4[1] |
| 10 | SCL | P4[0] | P1[2] | P3[5] | P4[0] | P4[0] | P3[0] | P4[0] |

Note 1: These pins are also used for onboard peripherals. Refer to the tables in the [A.5.2 Onboard Peripherals](#) section for connection details.

Table A-5. J4 Arduino Compatible Header Pin Map

| # | Arduino Pin | Pioneer Series Kits | | | | | | |
|----|-------------|---------------------|--------------------|-----------------|-------------|-------------|---------------------------------------|--------------------|
| | | CY8CKIT-042 | CY8CKIT-040 | CY8CKIT-042-BLE | CY8CKIT-044 | CY8CKIT-046 | CY8CKIT-041-40XX/ CY8CKIT-041-41XX | CY8CKIT-048 |
| 1 | D0 | P0[4] | P0[5] | P1[4] | P3[0] | P3[0] | P0[4] | P0[4] |
| 2 | — | — | — | — | — | P8[0] | — | — |
| 3 | D1 | P0[5] | P0[6] | P1[5] | P3[1] | P3[1] | P0[5] | P0[5] |
| 4 | — | — | — | — | — | P8[1] | — | — |
| 5 | D2 | P0[7] ¹ | P0[7] | P1[6] | P1[0] | P1[0] | P1[4] ¹ | P1[5] ¹ |
| 6 | — | — | — | — | — | P8[2] | — | — |
| 7 | D3 | P3[7] | P3[2] ¹ | P1[7] | P1[1] | P1[1] | P1[3] ¹ | P2[3] ¹ |
| 8 | — | — | — | — | — | P8[3] | — | — |
| 9 | D4 | P0[0] | P0[3] | P1[3] | P1[2] | P1[2] | P1[5] ¹ | P1[2] ¹ |
| 10 | — | — | — | — | — | P8[4] | — | — |
| 11 | D5 | P3[5] | P3[0] | P1[2] | P1[3] | P1[3] | P3[5] ¹ | P1[1] ¹ |
| 12 | — | — | — | — | — | P8[5] | — | — |
| 13 | D6 | P1[0] | P1[0] | P1[1] | P5[3] | P5[6] | P3[7] ¹ | P1[0] ¹ |
| 14 | — | — | — | — | — | P8[6] | — | — |
| 15 | D7 | P2[7] ¹ | P2[0] ¹ | P1[0] | P5[5] | P5[5] | P0[2] ¹ | P2[7] ¹ |
| 16 | — | — | — | — | — | P8[7] | — | — |

Note 1: These pins are also used for onboard peripherals. Refer to the tables in the [A.5.2 Onboard Peripherals](#) section for connection details.

A.5.2 Onboard Peripherals

Table A-6. CapSense Pin Map

| # | CapSense Pin | Pioneer Series Kits | | | | | | |
|----|---------------------|---------------------|-------------|-----------------|-------------|-------------|---------------------------------------|-------------|
| | | CY8CKIT-042 | CY8CKIT-040 | CY8CKIT-042-BLE | CY8CKIT-044 | CY8CKIT-046 | CY8CKIT-041-40XX/ CY8CKIT-041-41XX | CY8CKIT-048 |
| 1 | CapSense Sensor 1 | P1[1] | — | P2[1] | P4[4] | P0[6] | P1[7] | — |
| 2 | CapSense Sensor 2 | P1[2] | — | P2[2] | P4[5] | P4[5] | P2[0] | — |
| 3 | CapSense Sensor 3 | P1[3] | — | P2[3] | P4[6] | P4[4] | P2[1] | — |
| 4 | CapSense Sensor 4 | P1[4] | — | P2[4] | P3[4] | P4[7] | P2[2] | — |
| 5 | CapSense Sensor 5 | P1[5] | — | P2[5] | P3[5] | P4[6] | P2[3] | — |
| 6 | CapSense Sensor 6 | — | — | — | — | P7[4] | P0[3] | — |
| 7 | CapSense Sensor 7 | — | — | — | — | P7[5] | P0[6] | — |
| 8 | CapSense Sensor 8 | — | — | — | — | P7[6] | P0[0] | — |
| 9 | CapSense Sensor 9 | — | — | — | — | P7[7] | P1[5] | — |
| 10 | CapSense Sensor 10 | — | — | — | — | P0[0] | P1[0] | — |
| 11 | CapSense Sensor 11 | — | — | — | — | P0[1] | P1[1] | — |
| 12 | CapSense Sensor 12 | — | — | — | — | P7[2] | P1[2] | — |
| 13 | CapSense Sensor 13 | — | — | — | — | P7[3] | P1[3] | — |
| 14 | CapSense Sensor 14 | — | — | — | — | — | P1[4] | — |
| 15 | CapSense Sensor 15 | — | — | — | — | — | P0[1] | — |
| 16 | CapSense Sensor 16 | — | — | — | — | — | P0[2] | — |
| 17 | CapSense Sensor 17 | — | — | — | — | — | P3[7] | — |
| 18 | CMOD0 | P4[2] | P0[4] | P4[0] | P4[2] | P4[2] | P4[1] | — |
| 19 | CTANK0 | P4[3] | P0[2] | P4[1] | P4[3] | P4[3] | P4[0] | — |
| 20 | CMOD1 ¹ | — | — | — | — | P5[0] | — | — |
| 21 | CTANK1 ¹ | — | — | — | — | P5[1] | — | — |
| 22 | CintA ² | — | — | — | — | — | P4[2] | — |
| 23 | CintB ² | — | — | — | — | — | P4[3] | — |
| 24 | CapSense Shield | P0[1] | — | P1[6] | P0[1] | P0[2] | P3[5] | — |

Note 1: CMOD1, and CTANK1 are available only in the CY8CKIT-046 PSoC 4 L-Series Pioneer Kit.

Note 2: CintA and CintB are available only in the CY8CKIT-041-40XX and CY8CKIT-041-41XX.

Table A-7. Proximity Header Pin Map

| # | Proximity Pin | Pioneer Series Kits | | | | | | |
|---|---------------|---------------------|-------------|-----------------|-------------|-------------|---------------------------------------|-------------|
| | | CY8CKIT-042 | CY8CKIT-040 | CY8CKIT-042-BLE | CY8CKIT-044 | CY8CKIT-046 | CY8CKIT-041-40XX/ CY8CKIT-041-41XX | CY8CKIT-048 |
| 1 | PROXIMITY | — | P2[0] | P2[0] | P3[7] | P9[4] | P1[6] | — |
| 2 | | — | — | — | P3[6] | P9[5] | — | — |

Table A-8. RGB LED Pin Map

| # | LED Pin | Pioneer Series Kits | | | | | | |
|---|---------|---------------------|-------------|-----------------|-------------|-------------|---------------------------------------|-------------|
| | | CY8CKIT-042 | CY8CKIT-040 | CY8CKIT-042-BLE | CY8CKIT-044 | CY8CKIT-046 | CY8CKIT-041-40XX/ CY8CKIT-041-41XX | CY8CKIT-048 |
| 1 | Red | P1[6] | P3[2] | P2[6] | P0[6] | P5[2] | P3[4] | P1[4] |
| 2 | Green | P0[2] | P1[1] | P3[6] | P2[6] | P5[3] | P2[6] | P2[6] |
| 3 | Blue | P0[3] | P0[2] | P3[7] | P6[5] | P5[4] | P3[6] | P1[6] |

Table A-9. User Switch Pin Map

| # | Switch Pin | Pioneer Series Kits | | | | | | |
|---|------------|---------------------|-------------|-----------------|-------------|-------------|---------------------------------------|-------------|
| | | CY8CKIT-042 | CY8CKIT-040 | CY8CKIT-042-BLE | CY8CKIT-044 | CY8CKIT-046 | CY8CKIT-041-40XX/ CY8CKIT-041-41XX | CY8CKIT-048 |
| 1 | SW2 | P0[7] | — | P2[7] | P0[7] | P0[7] | P0[7] | P0[3] |

A.6 Bill of Materials

Refer to the BOM files in the following paths in the kit software installed:

- <Install_Directory>\CY8CKIT-041-40XX PSoC 4 S-Series Pioneer Kit\<version>\Hardware\CY8CKIT-041-40XX PCBA BOM.xlsx
- <Install_Directory>\CY8CKIT-041-40XX PSoC 4 S-Series Pioneer Kit\<version>\Hardware\CY8CKIT-041-40XX Flex PCBA BOM.xlsx

Revision History



Document Revision History

| Document Title: CY8CKIT-041-40XX PSoC® 4 S-Series Pioneer Kit Guide | | | | |
|---|------------|------------|------------------|---|
| Document Number: 002-10238 | | | | |
| Revision | ECN Number | Issue Date | Origin of Change | Description of Change |
| ** | 5110319 | 01/27/2016 | SSHH | New kit guide. |
| *A | 5266004 | 05/12/2016 | SRDS | Updated kit images in all sections. Updated Introduction chapter on page 5. Updated Software Installation chapter on page 17. Updated Kit Operation chapter on page 20. Updated Code Examples chapter on page 32. Updated Appendix chapter on page 36. Updated to new template. |
| *B | 5497859 | 10/27/2016 | DCHE / SRDS | Updated Introduction chapter on page 5: Updated "Board Details" on page 6: Updated Figure 1-2 . Updated Figure 1-3 . Updated Table 1-1 . Updated "Additional Learning Resources" on page 14: Updated description. Updated Software Installation chapter on page 17: Updated "Install Software" on page 17: Updated description. Updated Kit Operation chapter on page 20: Updated "Theory of Operation" on page 20: Updated description. Updated "How to open the Kit Case" on page 26: Updated description. Updated "Removing the Overlay" on page 28: Updated description. Updated "KitProg2" on page 29: Updated "Programming using PSoC Programmer" on page 30: Updated description. |

Document Revision History (*continued*)

| Document Title: CY8CKIT-041-40XX PSoC® 4 S-Series Pioneer Kit Guide | | | | |
|---|------------|------------|------------------|---|
| Document Number: 002-10238 | | | | |
| Revision | ECN Number | Issue Date | Origin of Change | Description of Change |
| *B (cont.) | 5497859 | 10/27/2016 | DCHE / SRDS | Updated Code Examples chapter on page 32: Updated description. Updated "Using the Kit Code Examples" on page 32: Updated Figure 4-1 . Updated "Code Examples" on page 34: Updated Table 4-1 . Updated description. Added Figure 4-4 . Updated Appendix chapter on page 36: Updated "Hardware Functional Description" on page 36: Updated "Power Supply System" on page 37: Updated description. Updated "Battery Charging Circuit" on page 38: Updated description. Updated "Current Measurement Switch" on page 39: Updated Figure A-6 (Updated Caption only). Updated description. Updated "Push Buttons" on page 43: Updated description. Updated "Migrating Projects Across Different Pioneer Series Kits" on page 48: Updated Figure A-14 . Updated "Arduino Uno Compatible Headers" on page 49: Updated Table A-2 . Updated Table A-3 . Updated Table A-4 . Updated Table A-5 . Updated "Onboard Peripherals" on page 51: Updated Table A-6 . Updated Table A-7 . Updated Table A-8 . Updated Table A-9 . |
| *C | 5741242 | 05/18/2017 | AESATMP8 | Updated Cypress Logo and Copyright. |
| *D | 6501083 | 03/05/2019 | BHAT | No technical updates. Completing Sunset Review. |